

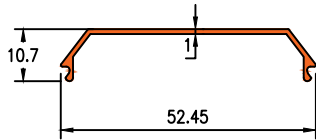

Darshan Extrusions Pvt. Ltd.

Die No.19401

0.183KG/M



Die No.19400

0.280KG/M

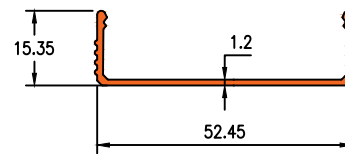

Die No.19635

0.135KG/M

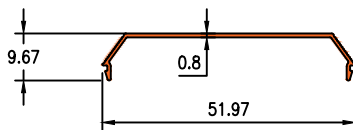

Die No.19634

0.174KG/M

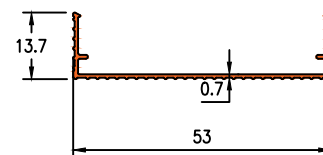

Die No.19523

0.121KG/M

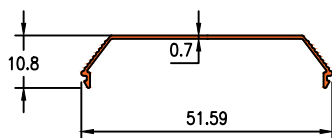

Die No.19521

0.184KG/M

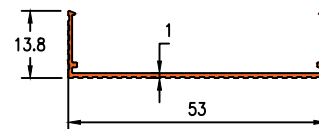

Die No.19522

0.117KG/M

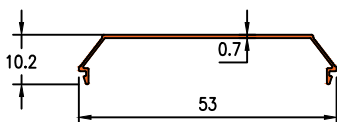

LED



Darshan Extrusions Pvt. Ltd.

Die No. 19686

0.110KG/M

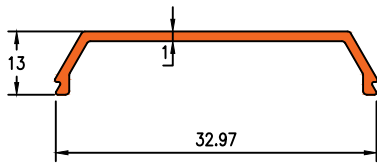

Die No. 19687

0.210KG/M

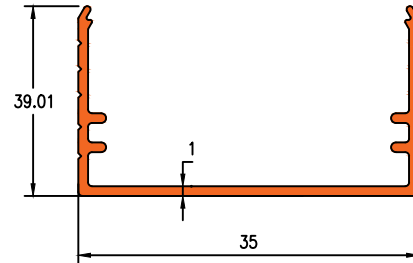

Die No. 19693

0.285KG/M

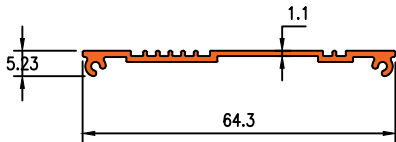

Die No. 19692

0.653KG/M

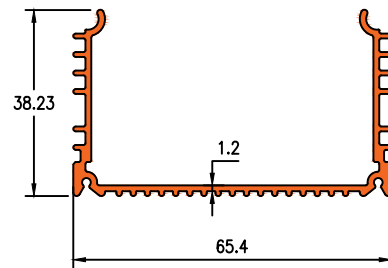

Die No. 19001

0.220KG/M

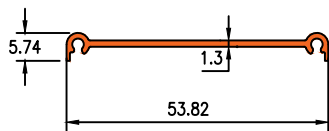

Die No. 19000

0.374KG/M

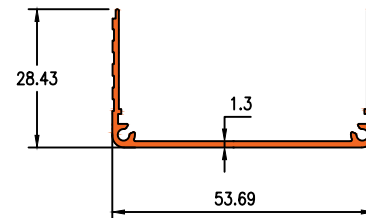

Die No. PB-4-3

0.418KG/M

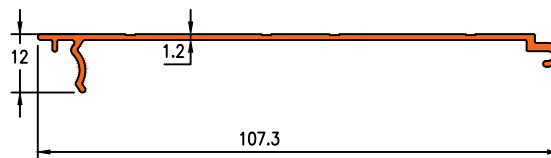

LED



Darshan Extrusions Pvt. Ltd.

Die No. PB-4-2

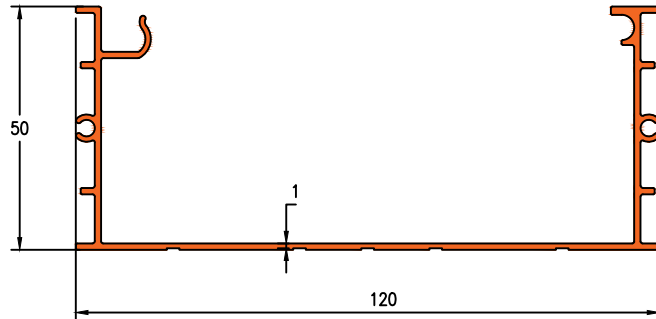

0.963KG/M

Die No. 19601

0.987KG/M

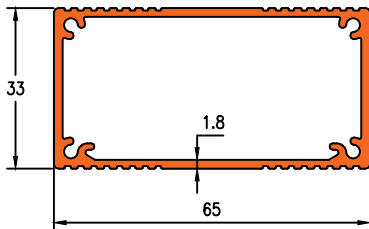

Die No.10204

1.067KG/M

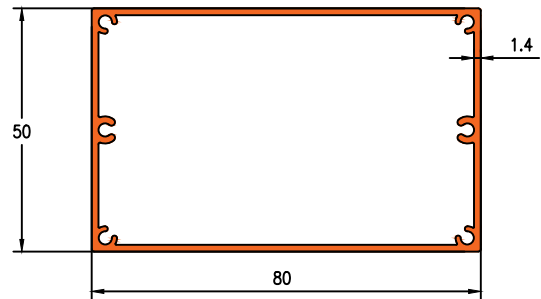

Die No. 19602

1.243KG/M

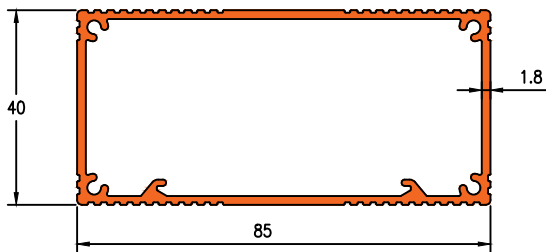

Die No.1302

1.057KG/M

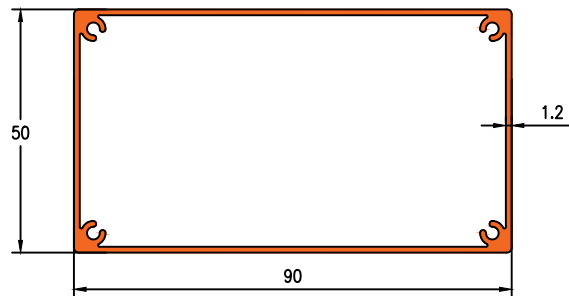

Die No. 19110

1.572KG/M

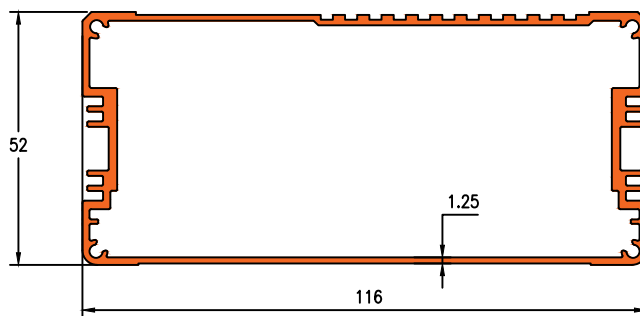

LED



Darshan Extrusions Pvt. Ltd.

Die No. 1266

1.023 KG/M

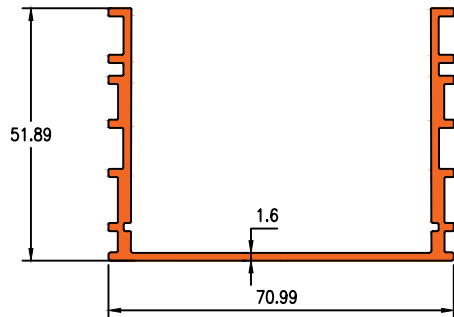

Die No. 16025

1.217 KG/M

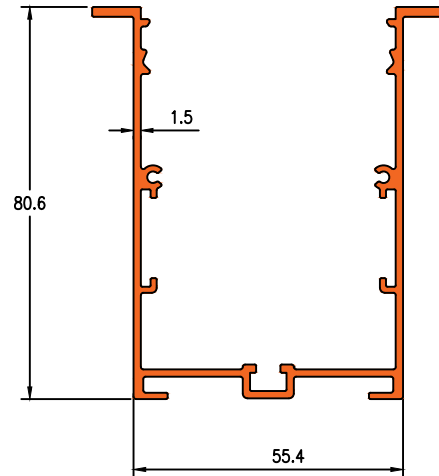

Die No. 16024

1.125 KG/M

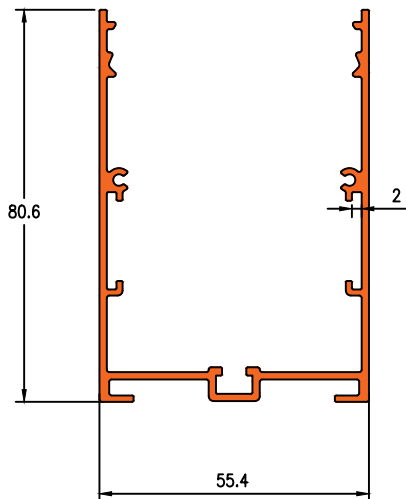

Die No. 19373

1.228 KG/M

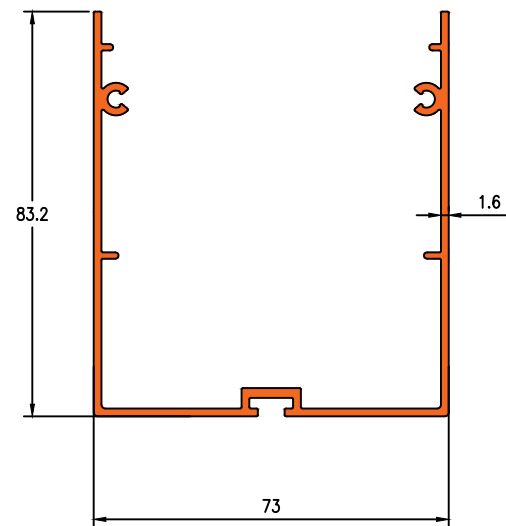

Die No. 19106

1.083 KG/M

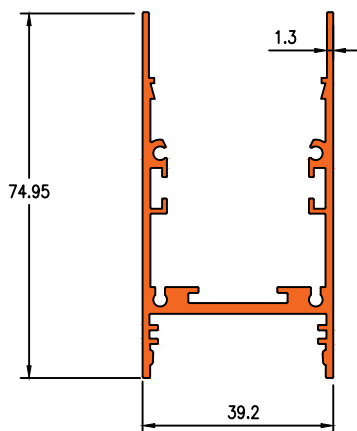

LED



Darshan Extrusions Pvt. Ltd.

Die No. 19732

1.648KG/M

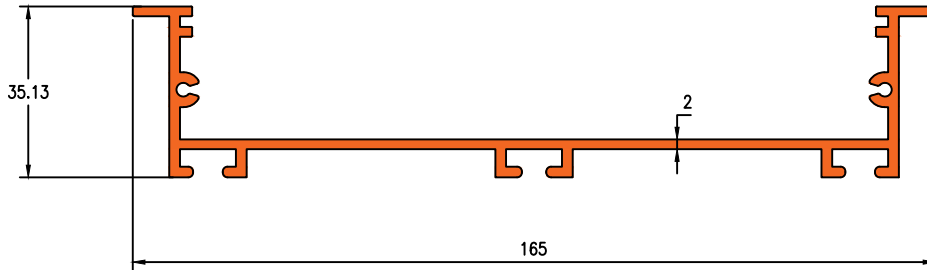

Die No. 19734

0.455KG/M

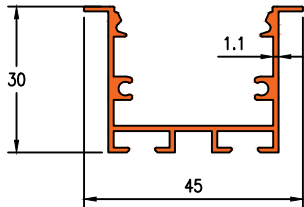

Die No. 19904

0.485KG/M

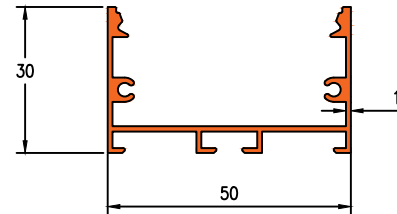

Die No. 19907

0.469KG/M

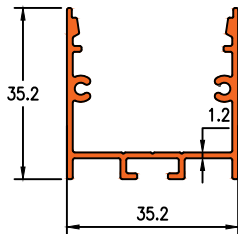

Die No. 1267

0.761KG/M

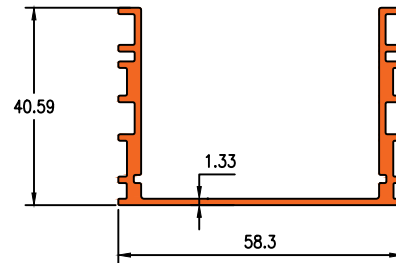

Die No. 19437

0.458KG/M

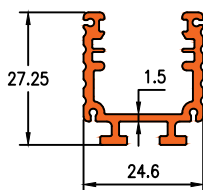

Die No. 19701

0.451KG/M

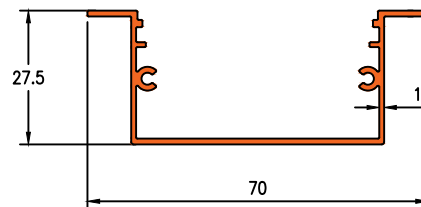

LED



Darshan Extrusions Pvt. Ltd.

Die No. 23005

0.264KG/M

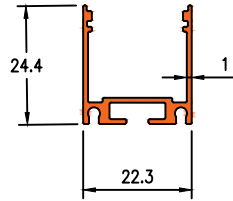

Die No. 23007

0.286KG/M

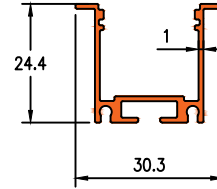

Die No. 23006

0.078KG/M

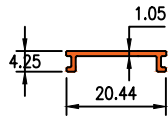

Die No. 19741

0.797KG/M

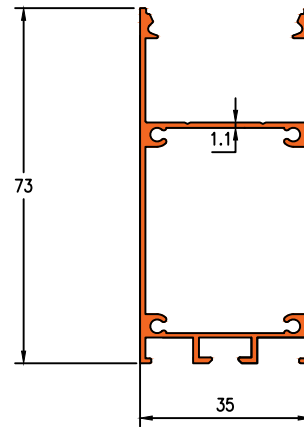

Die No. 19158

0.966KG/M

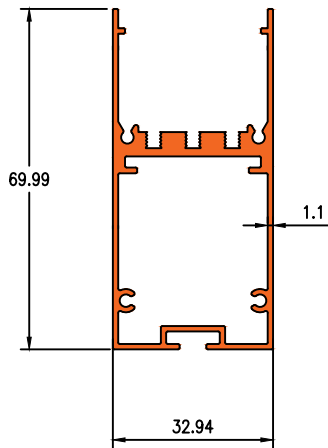

Die No. 16164

1.077KG/M

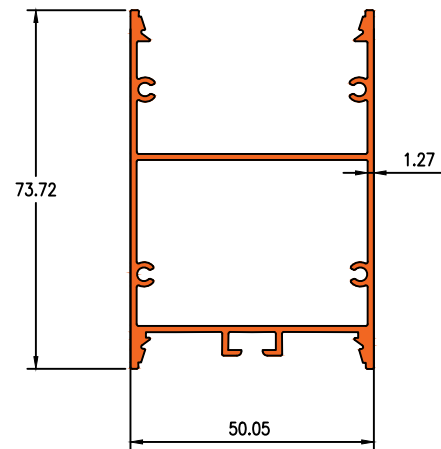

LED



Darshan Extrusions Pvt. Ltd.

Die No. 19908

1.106 KG/M

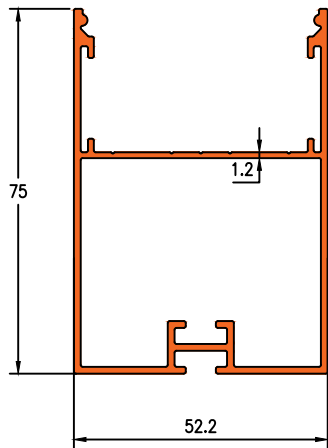

Die No. 19173

0.906KG/M

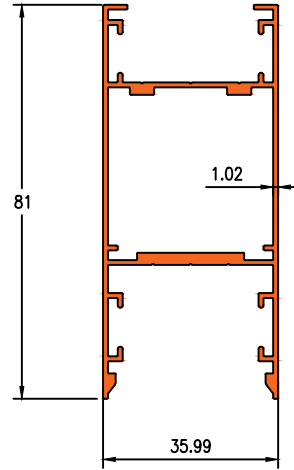

Die No. 19202

1.008KG/M

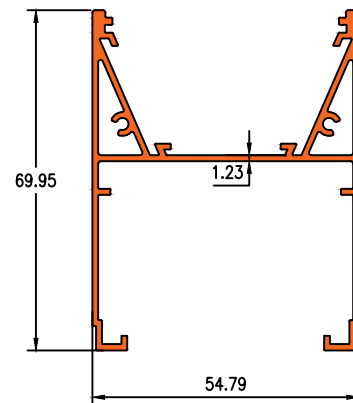

Die No. 19168

1.056KG/M

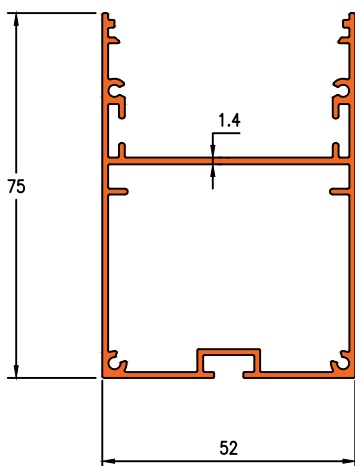

Die No. 19203

0.383KG/M

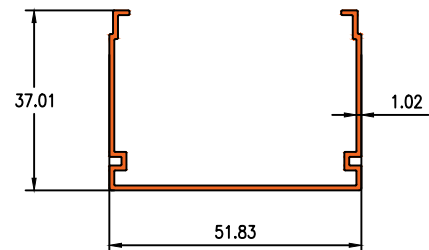

LED



Darshan Extrusions Pvt. Ltd.

Die No. 19190

0.897KG/M

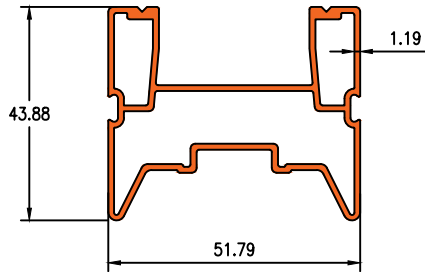

Die No. 19325

0.808KG/M

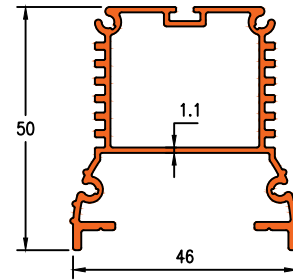

Die No. 1276

1.690KG/M

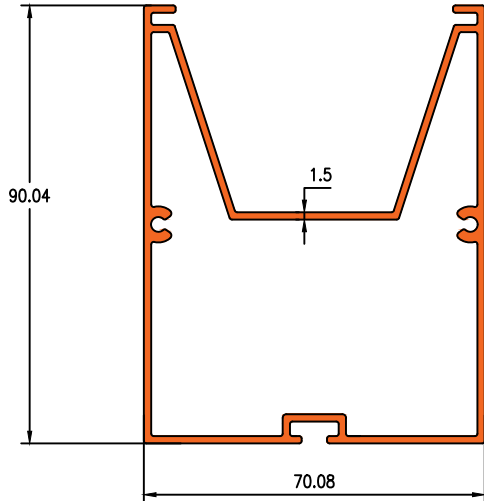

Die No. 19716

0.917KG/M

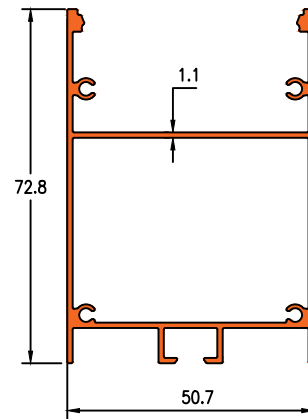

Die No. 19198

0.918KG/M

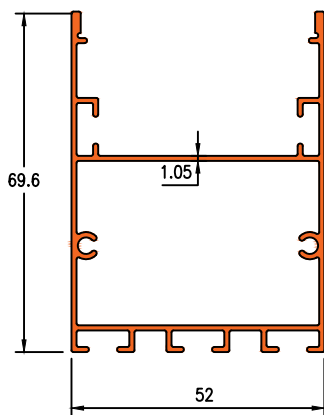

Die No. 19455

0.904KG/M

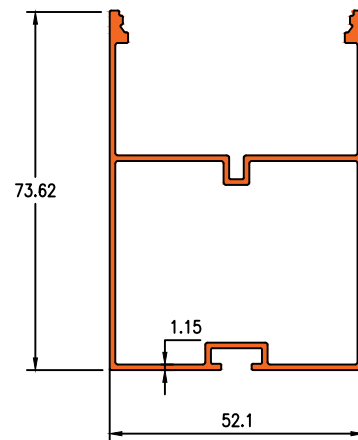

LED



Darshan Extrusions Pvt. Ltd.

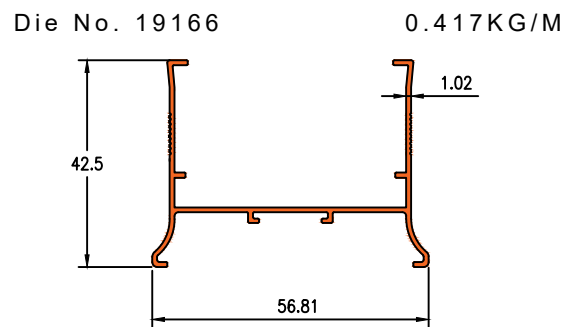
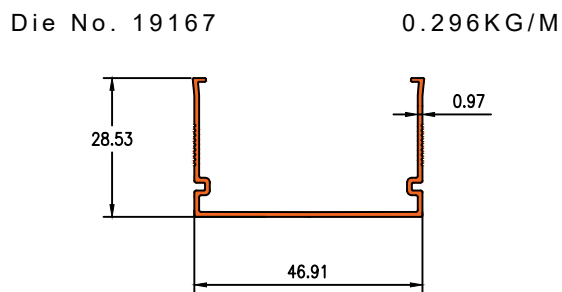
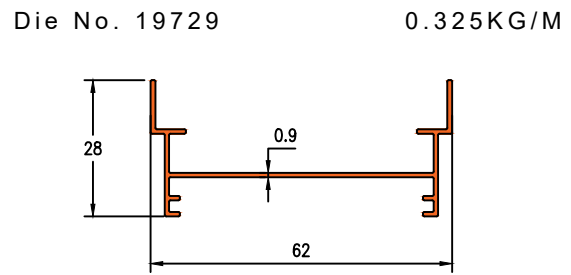
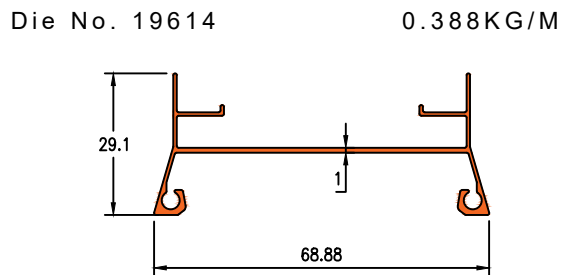
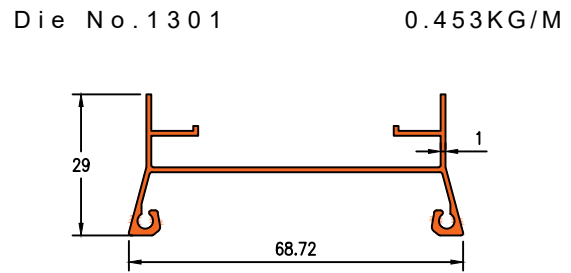
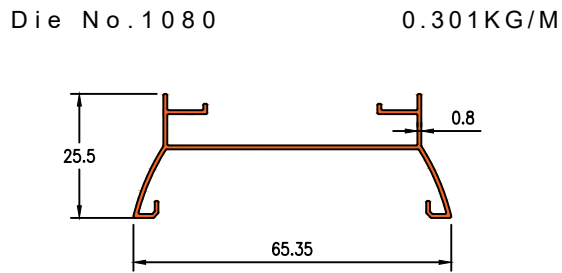
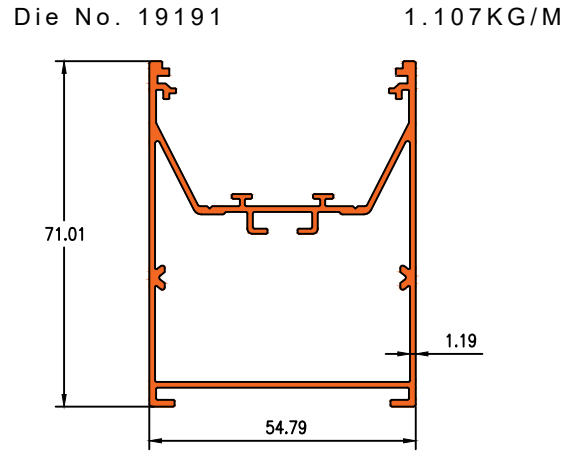
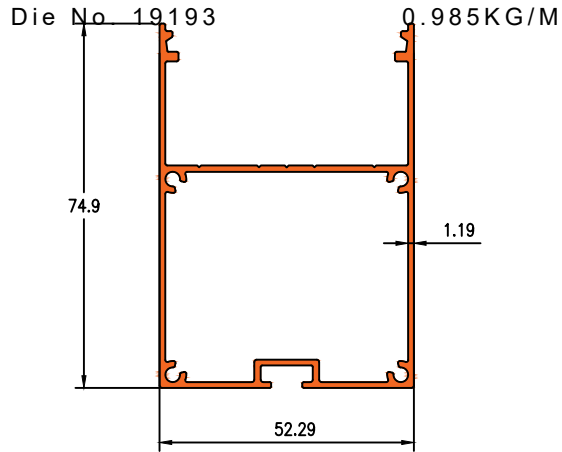

LED



Darshan Extrusions Pvt. Ltd.

Die No. 1275

0.145KG/M

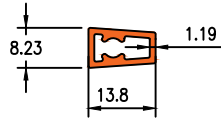

Die No. 19530

0.117KG/M

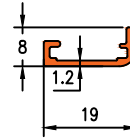

Die No. 19529

0.850KG/M

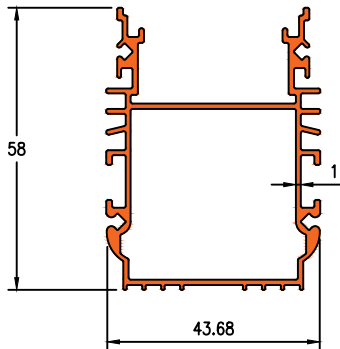

Die No. 19531

0.554KG/M

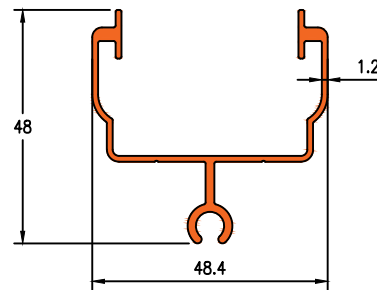

Die No. 19723

0.190KG/M

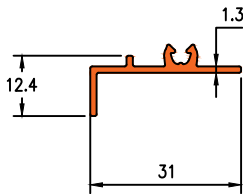

Die No. 19676

0.351KG/M

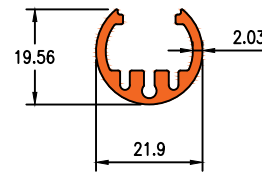

Die No. 1238

0.327KG/M

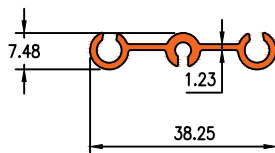

Die No. 1250

0.453KG/M

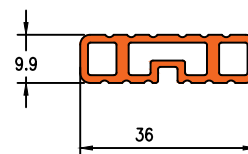

LED



Darshan Extrusions Pvt. Ltd.

Die No. 1248

0.522KG/M

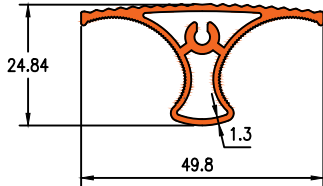

Die No. 19467

1.183KG/M

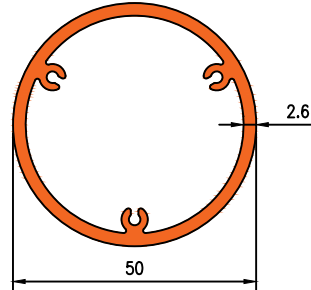

Die No. 19183

0.485KG/M

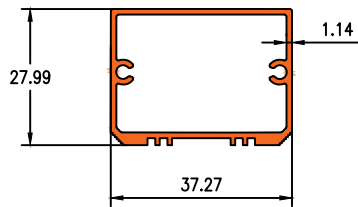

Die No. 1079

0.311KG/M

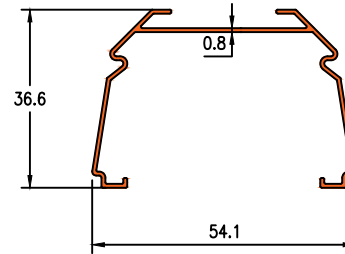

Die No. 1237

0.209KG/M

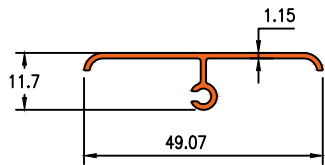

Die No. 1249

0.512KG/M

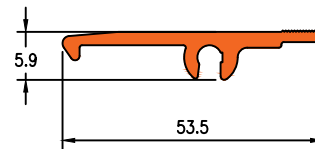

Die No. 1264

0.443KG/M

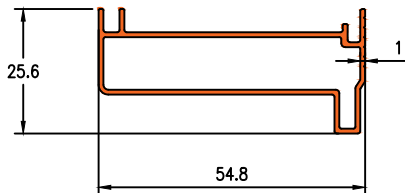

Die No. 1242

1.433KG/M

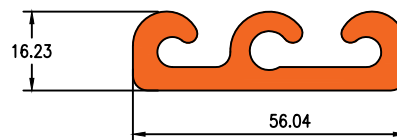

LED



Darshan Extrusions Pvt. Ltd.

Die No. 23018

0.435KG/M

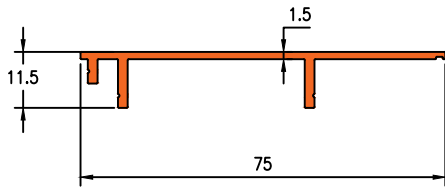

Die No. 19375

0.452KG/M

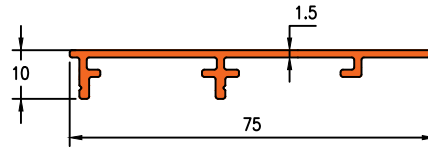

Die No. 1240

0.562KG/M

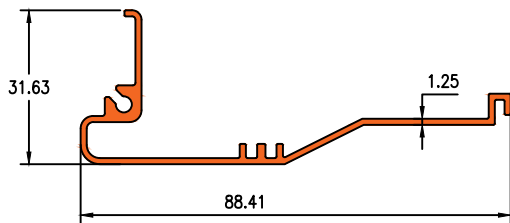

Die No. 19733

1.343KG/M

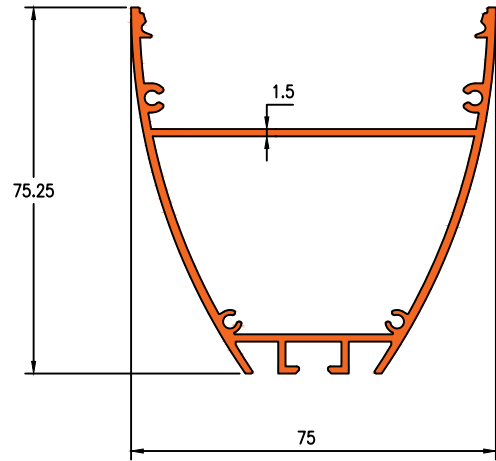

Die No. 20035

2.081KG/M

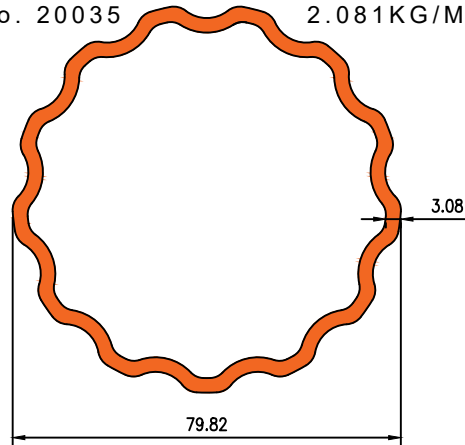

Die No. 20036

3.016KG/M

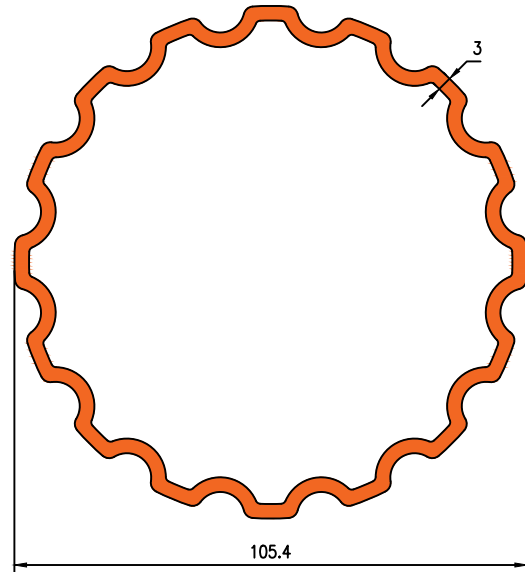

Die No. 1251

1.123KG/M

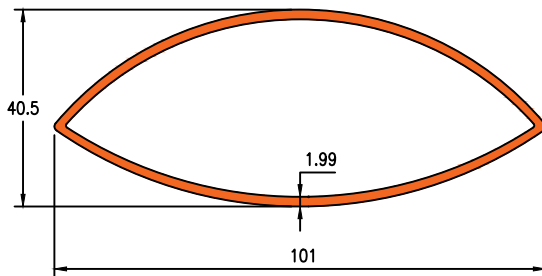

LED



Darshan Extrusions Pvt. Ltd.

Die No. 1278

1.313KG/M

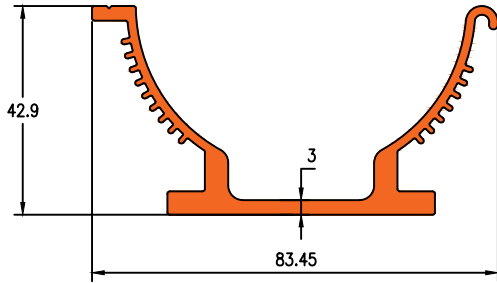

Die No. 1271

1.437KG/M

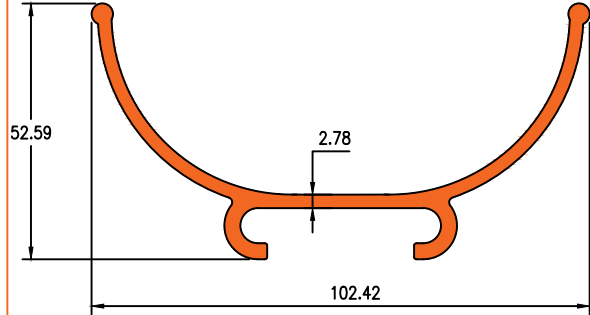

Die No. 1245

0.690KG/M

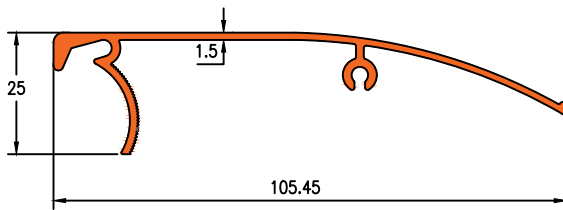

Die No. 1252

1.384KG/M

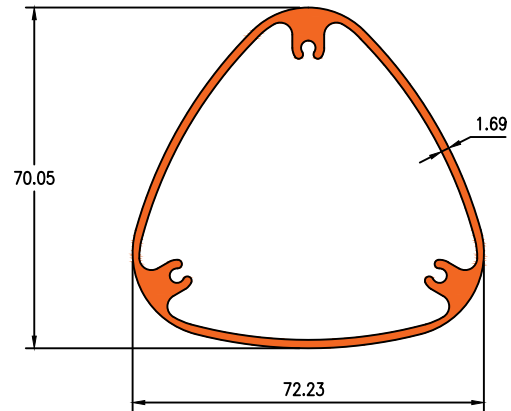

Die No. 19962

0.903KG/M

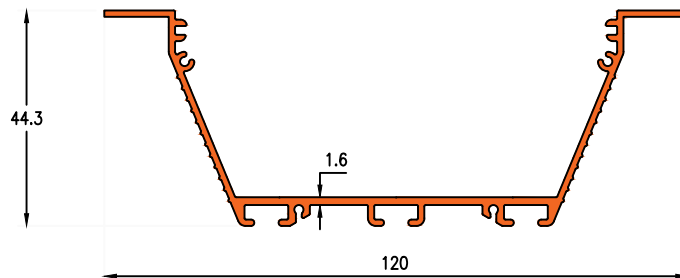

Die No. 1244

0.665KG/M

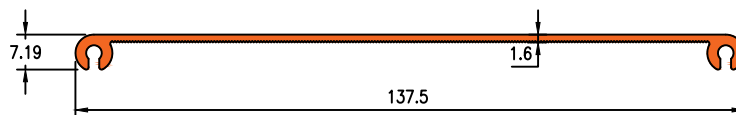

LED



Darshan Extrusions Pvt. Ltd.

Die No.19074

2.730Kg/m

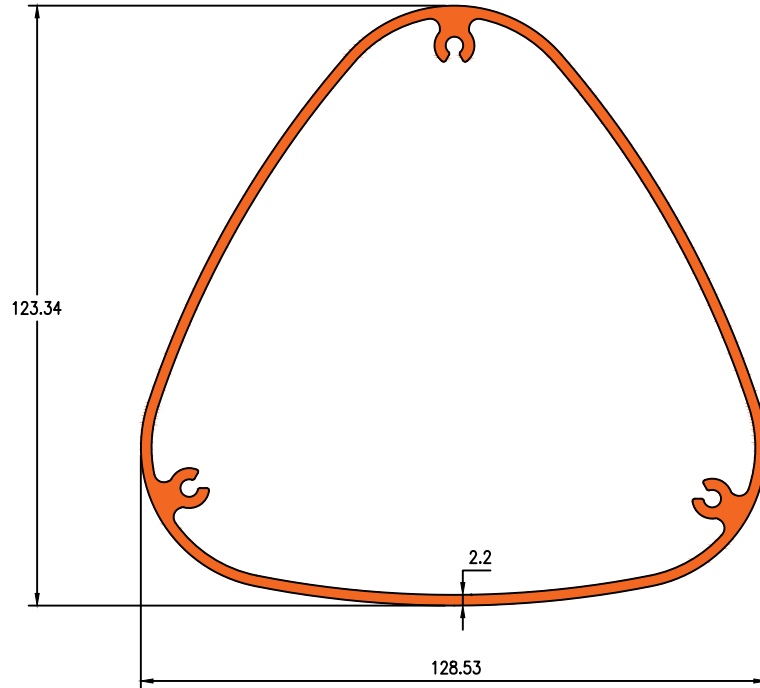

Die No.19075

2.120Kg/m

Die No.19076

2.370Kg/m

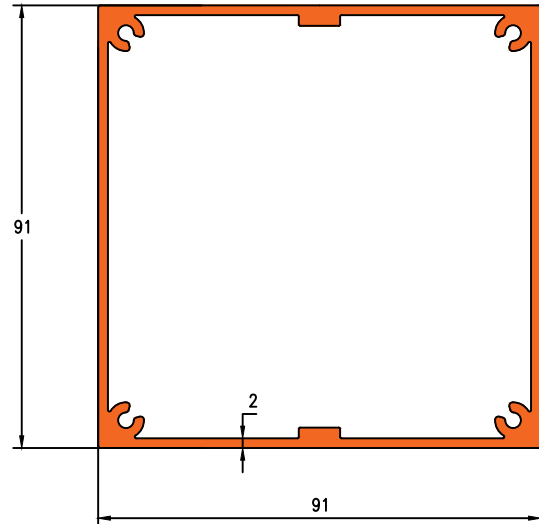
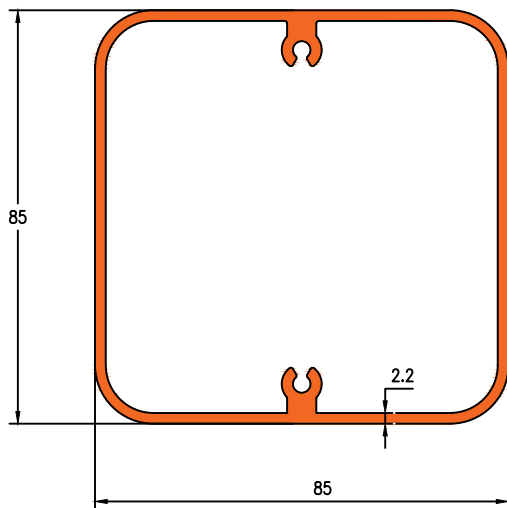

LED



Darshan Extrusions Pvt. Ltd.

Die No. 16241

0.750Kg/m

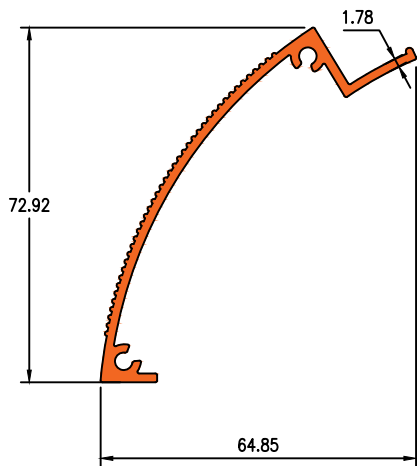

Die No. 1428

1.507Kg/m

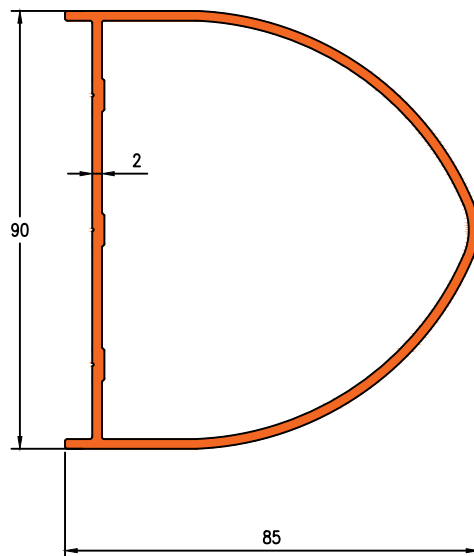

LED



Darshan Extrusions Pvt. Ltd.

Die No.19995

01.297 Kg/m

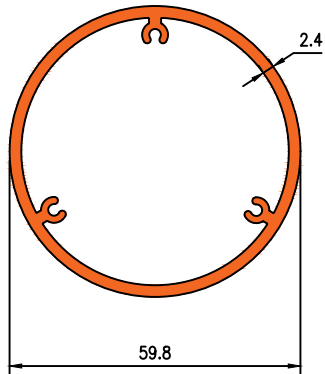

Die No.2008

1.910 Kg/m

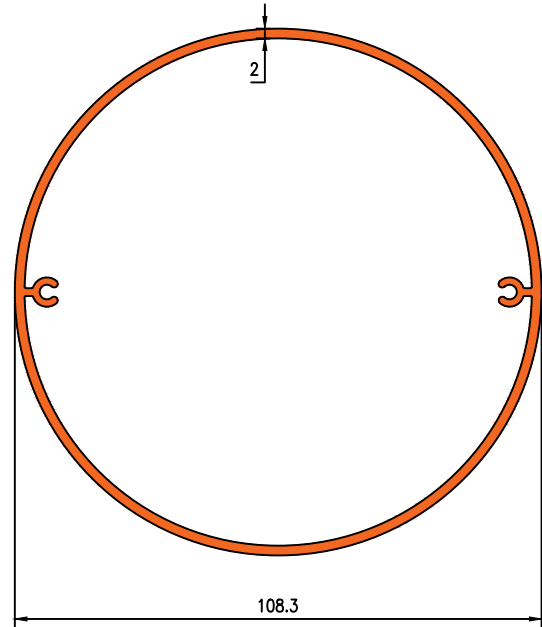

Die No.19995

1.910 Kg/m

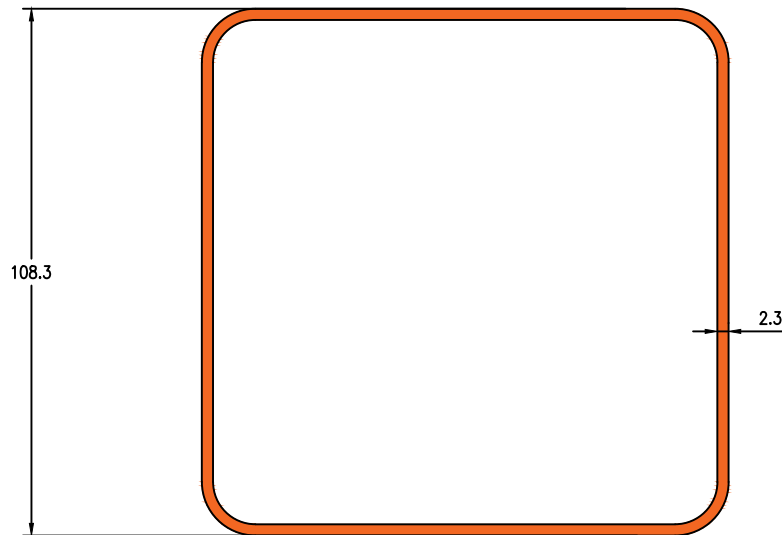

RAILWAY SECTION