



# Darshan Extrusions Pvt. Ltd.

Die No.1287

0.299KG/M

Die No.1281

0.579KG/M

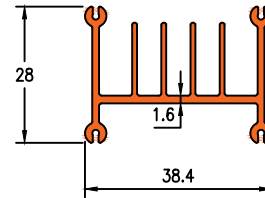
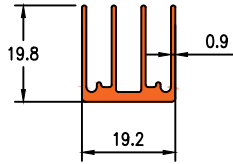

Die No.1288

1.164KG/M

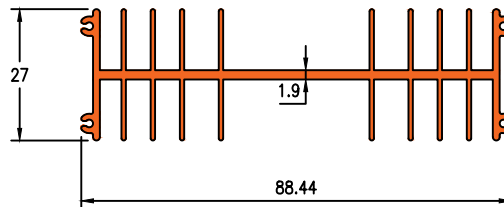

Die No.19002

1.966KG/M

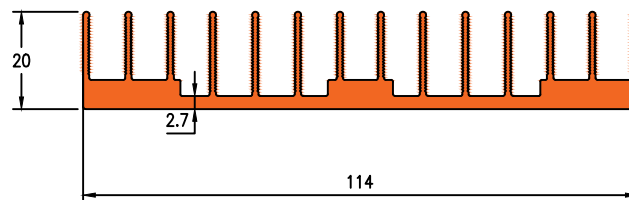

Die No.19003

2.068KG/M

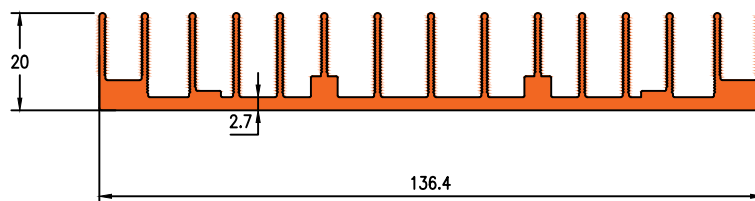

HEAT SINK



# Darshan Extrusions Pvt. Ltd.

Die No. 7061

2.336KG/M

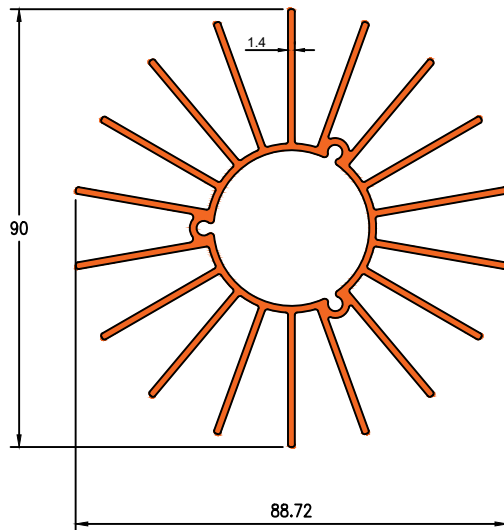

Die No. 19019

6.452KG/M

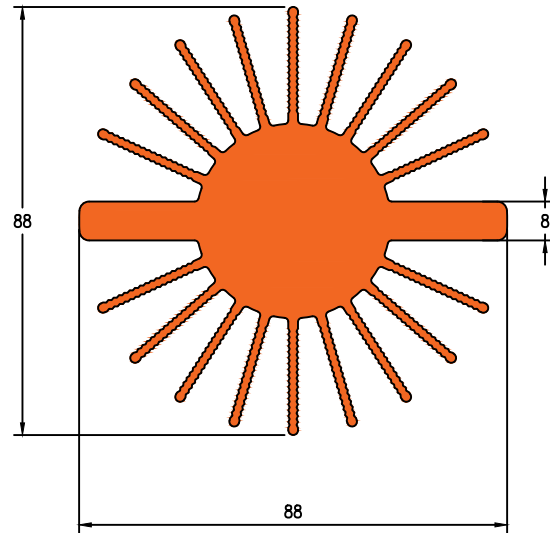

Die No. 19020

4.967KG/M

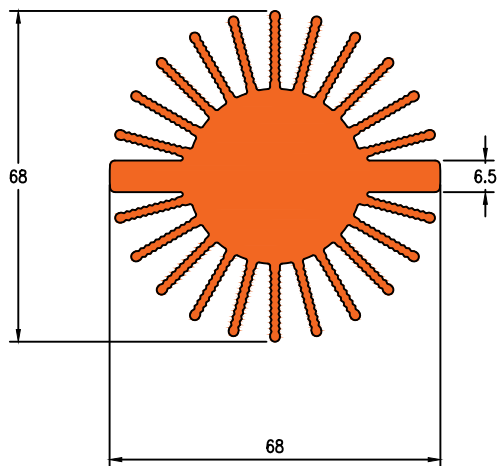

Die No. 19018

0.393KG/M

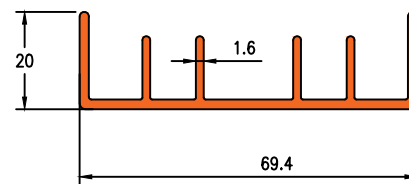

Die No. 19381

0.093KG/M

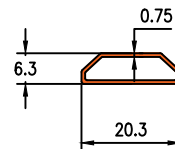

HEAT SINK



# Darshan Extrusions Pvt. Ltd.

Die No.19137

1.423KG/M

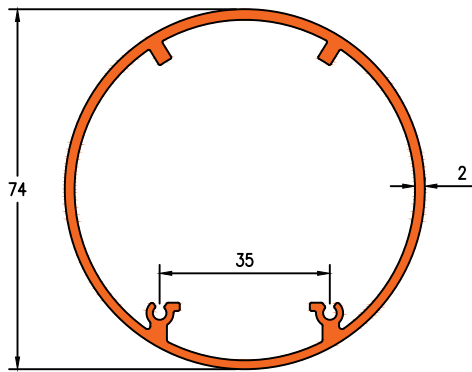

Die No.19138

2.030KG/M

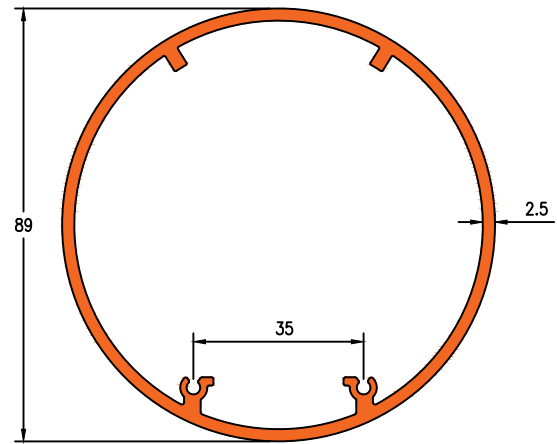

Die No.19139

4.140KG/M

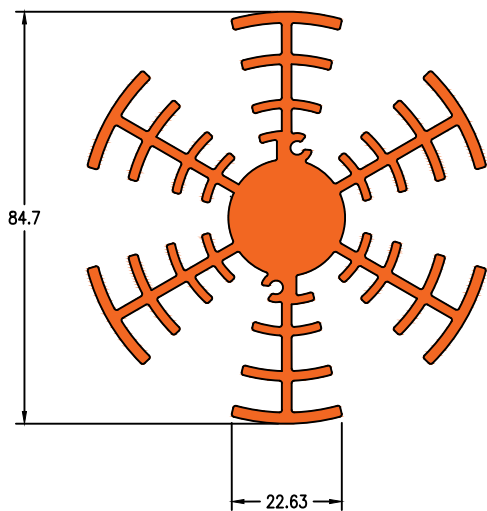

Die No.19140

3.481KG/M

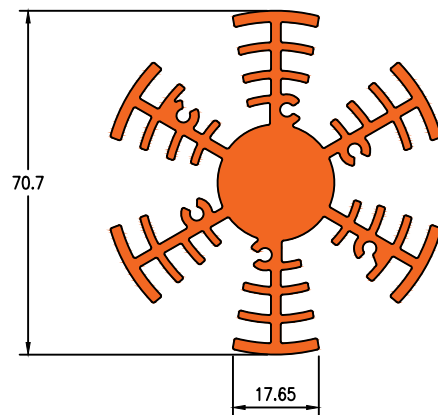

HEAT SINK



# Darshan Extrusions Pvt. Ltd.

Die No.19067

1.736KG/M

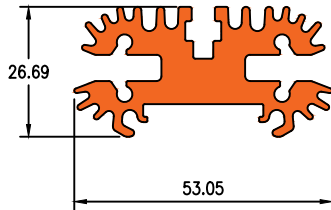

Die No.19524

4.418KG/M

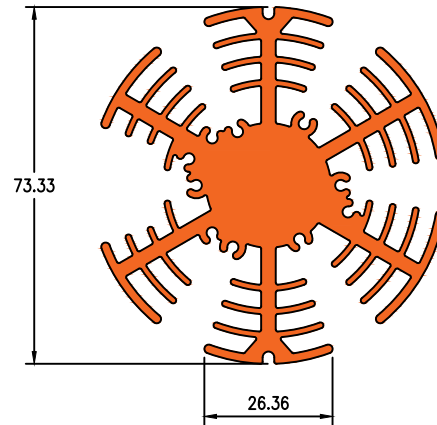

Die No.19525

3.217KG/M

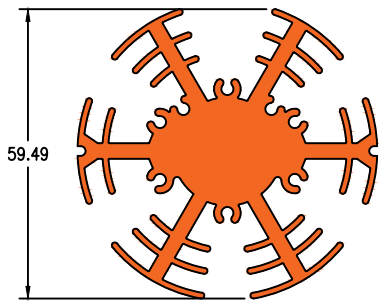

Die No.19526

2.176KG/M

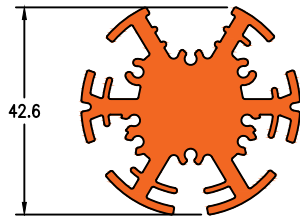

Die No.19818

2.750KG/M

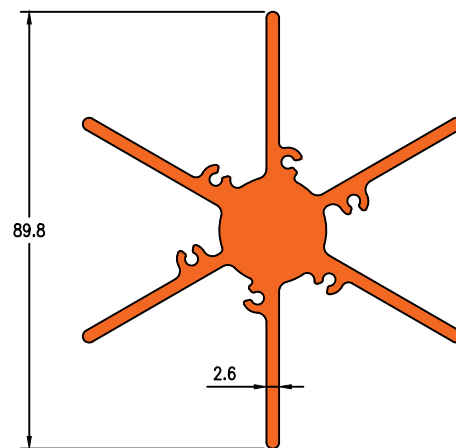

Die No.19385

3.244KG/M

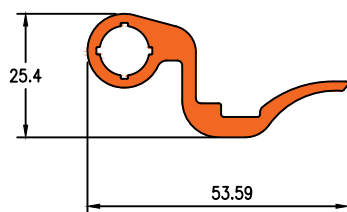

HEAT SINK



# Darshan Extrusions Pvt. Ltd.

Die No.23009

3.175KG/M

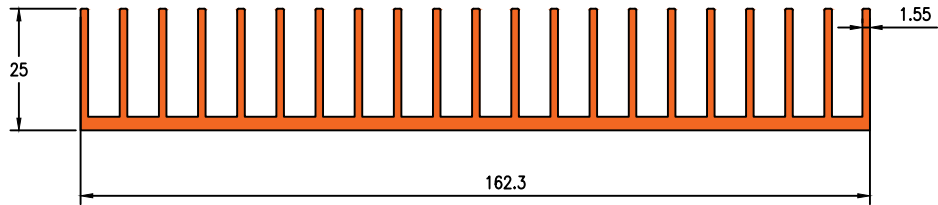

Die No.19958

9.823KG/M

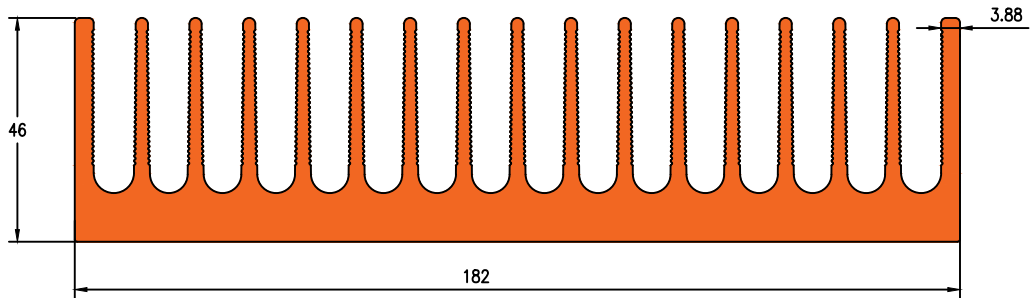

Die No.19819

2.291KG/M

Die No.19393

1.747KG/M

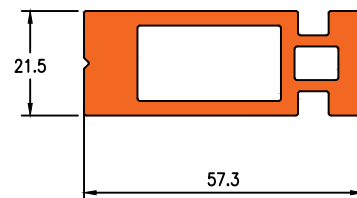
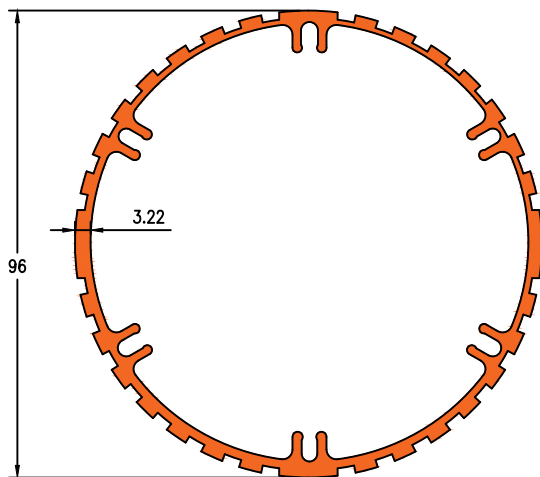

Die No.19382

0.151KG/M

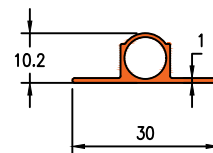

HEAT SINK



# Darshan Extrusions Pvt. Ltd.

Die No.19535

0.623KG/M

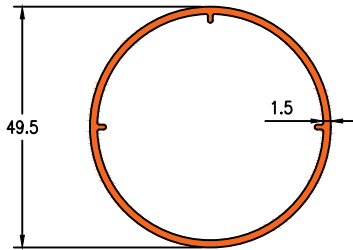

Die No.19532

1.161KG/M

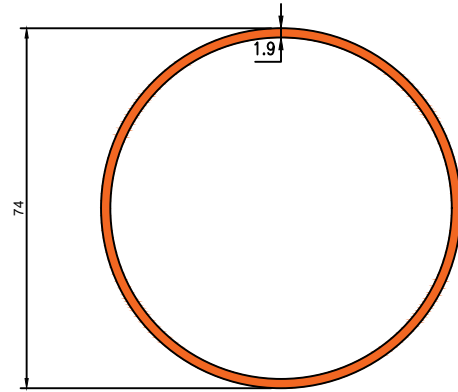

Die No.19392

2.551KG/M

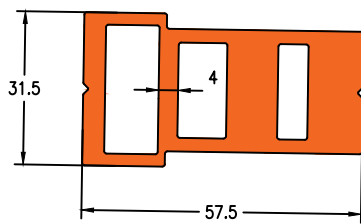

Die No.19533

1.098KG/M

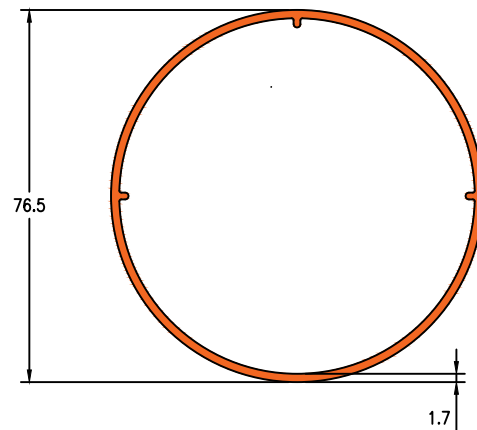

Die No.19534

0.667KG/M

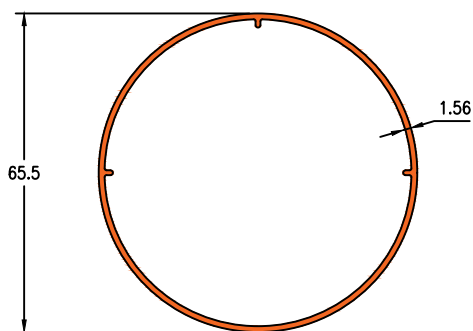

Die No.19014

0.502KG/M

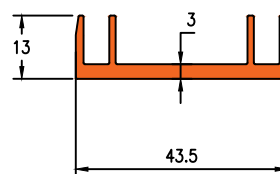

HEAT SINK



# Darshan Extrusions Pvt. Ltd.

Die No. 19480

0.335KG/M

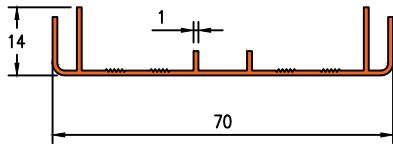

Die No. 20021

3.250KG/M

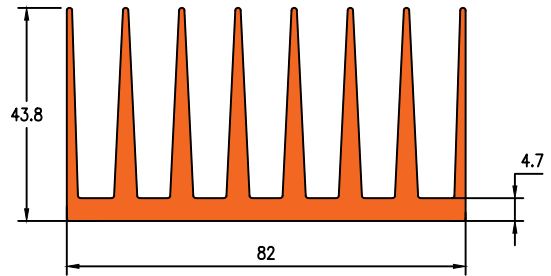

Die No. 23010

0.613KG/M

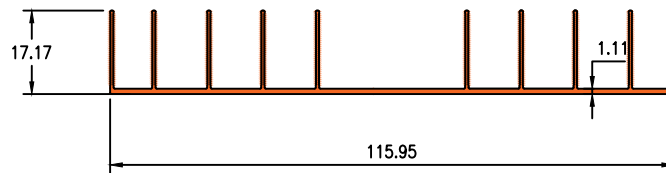

Die No. 19995

1.297KG/M

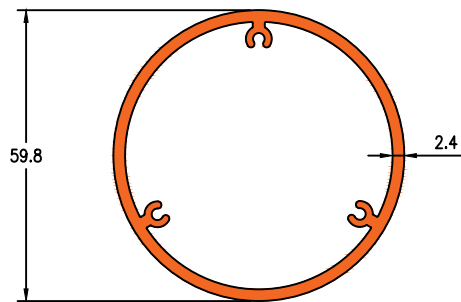

Die No. 19996

2.269KG/M

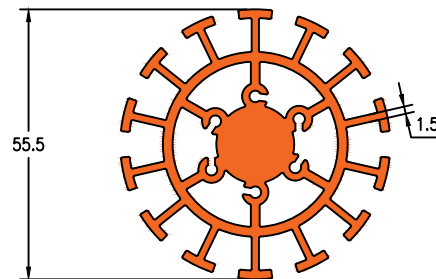

HEAT SINK