



Darshan Extrusions Pvt. Ltd.

ALUMINIUM EXTRUSIONS

CATALOGUE INDEX

GENERAL SHAPES

• FLAT BAR	03
• EQUAL ANGLE	06
• UNEQUAL ANGLE	07
• ROUND PIPE	08
• ROUND BAR	10
• SQUARE BAR	11
• SQUARE TUBE	12
• RECTANGULAR TUBE	13
• SLOTTED TUBE	15
• U/C CHANNEL	18
• T-SECTION	19
• E-SECTION	20

ARCHITECTURAL

1. WINDOWS

CONVENTIONAL WINDOWS		SYSTEM WINDOWS	
• 18MM	21	• 20MM	38
• 19MM	28	• 22MM	41
• 20MM	29	• 25MM	42
• 25MM	30	• 26MM	50
• 30MM	36	• 27MM	51
		• 27MM PRIME	76
		• 28MM	81
		• 29MM	83
		• 30MM	86
		• 35MM	90
		• 37MM	110
		• MINIMAL	114

2. CASEMENT WINDOW & DOOR

• 29MM CASEMENT	126
• 35MM CASEMENT	127
• 40MM CASEMENT	130
• 42MM CASEMENT	133
• 45MM CASEMENT	134
• 48MM CASEMENT	140
• 49MM CASEMENT	141
• 50MM CASEMENT	142
• 52MM CASEMENT	147
• 55MM CASEMENT	148
• CASEMENT MISCELLANEOUS	149

3. HARDWARE

• CORNER CLEATS	159
• HINGES	161
• BEARING	163
• TOWER BOLTS	164
• ALDROP	166
• HARDWARE MISCELLANEOUS	167

4. RAILING 174

5. MODULAR 186

6. STIFFENER 200

7. DOME 201

8. DISPLAY 202

9. VENETIAN BLINDS 204

10. CLADDING 214

11. LADDER 223

12. SUBFRAME 227

13. INVISIBLE GRILL 230

14. PLEATED MOSQUITO MESH 231

**15. ARCHITECTURAL
MISCELLANEOUS** 235

INDUSTRIAL

1. ELECTRICAL

- HEAT SINK 247
 - LED SECTION 254
-

2. SOLAR 270

3. AUTOMOBILE 280

4. CARRIER 285

5. FAN BLADE 286

6. ELEVATOR 287

7. INDUSTRIAL MISCELLANEOUS 290

FACADE

1. SEMI UNITIZED STRUCTURAL GLAZING

- 32MM SERIES 293
 - 40MM SERIES 295
 - 45MM SERIES 296
 - 50MM SERIES 297
 - 55MM SERIES 299
 - 56MM SERIES 304
 - 57MM SERIES 305
 - 60MM SERIES 307
 - 65MM SERIES 311
 - 67MM SERIES 312
 - 68MM SERIES 317
 - 70MM SERIES 318
 - PRESSURE PLATE & COVER CAP 320
 - SASH FRAMES 325
 - TOGGLE 329
-

2. UNITIZED GLAZING

- 85MM SERIES 330
 - 100MM SERIES 332
 - 116MM SERIES 334
 - 120MM SERIES 336
 - 140MM SERIES 341
 - 160MM SERIES 343
-

3. PARTITION

- DOOR & PARTITIONS 345
 - DOORS & DOOR FRAME 348
 - DEMOUNTABLE PARTITION 375
 - **COMBINATION PIPE**
 - 40MM SERIES 397
 - 42MM SERIES 402
 - 49 MM SERIES 404
-

4. LOUVERS 406

5. BULL NOSE 410

6. FACADE MISCELLANEOUS 414

• **MISCELLANEOUS PROFILES** 420



FLAT BAR



SR.NO.	A	B	WT/M	WT/12FT	SR.NO.	A	B	WT/M	WT/12FT
1	12	2.5	0.082	0.300	39	30	10	0.847	3.100
2	12	3	0.098	0.360	40	30	12	0.984	3.600
3	12	6	0.199	0.730	41	30	16	1.036	3.790
4	12	5	0.164	0.600	42	31	19	1.525	5.580
5	16	6	0.260	0.950	43	32	1.5	0.137	0.500
6	16	10	0.437	1.600	44	35	1.75	0.164	0.600
7	18	2.5	0.123	0.450	45	35	6	0.571	2.090
8	18	5	0.246	0.900	46	35.5	40	1.338	4.900
9	19	1.5	0.071	0.260	47	38	2	0.205	0.750
10	19	2	0.109	0.400	48	38	3	0.328	1.200
11	19	2.5	0.128	0.470	49	38	5	0.508	1.860
12	19	2.8	0.148	0.540	50	38	9	0.937	3.430
13	19	3	0.154	0.563	51	38	12	1.246	4.560
14	19	3.5	0.156	0.570	52	38	25	2.568	9.400
15	19	5	0.260	0.950	53	40	2	0.216	0.790
16	19	6	0.328	1.200	54	40	3	0.317	1.160
17	19	12	0.650	2.380	55	40	4	0.437	1.600
18	20	3	0.178	0.650	56	40	5	0.574	2.100
19	20	5	0.273	1.000	57	40	6	0.656	2.400
20	20	6	0.342	1.250	58	40	8	0.869	3.180
21	20	10	0.555	2.030	59	40	10	1.093	4.000
22	22	20	1.202	4.400	60	40	12	1.311	4.800
23	25	1.5	0.104	0.380	61	40	12	1.366	5.000
24	25	2	0.137	0.500	62	40	15	1.639	6.000
25	25	2.7	0.178	0.650	63	40	16	1.754	6.420
26	25	3	0.205	0.750	64	50	2	0.268	0.980
27	25	4	0.265	0.970	65	50	3	0.432	1.580
28	25	5	0.342	1.250	66	50	4	0.546	2.000
29	25	6	0.402	1.470	67	50	5	0.683	2.500
30	25	8	0.527	1.930	68	50	6	0.806	2.950
31	25	10	0.678	2.480	69	50	8	1.093	4.000
32	25	12	0.820	3.000	70	50	10	1.339	4.900
33	25.6	2.8	0.191	0.700	71	50	10	1.380	5.050
34	30	1.8	0.158	0.580	72	50	12	1.639	6.000
35	30	3	0.246	0.900	73	50	16	2.186	8.000
36	30	5	0.410	1.500	74	50	25	3.383	12.380
37	30	6	0.434	1.590	75	56	3	0.451	1.650
38	30	8	0.656	2.400	76	60	3	0.492	1.800



FLAT BAR



SR.NO.	A	B	WT/M	WT/12FT	SR.NO.	A	B	WT/M	WT/12FT
77	60	6	0.820	3.000	115	100	25	6.831	25.000
78	60	10	1.612	5.900	116	120	10	3.224	11.800
79	60	12	1.945	7.120	117	120	12	3.907	14.300
80	60	15	2.459	9.000	118	120	20	6.500	23.790
81	63	3	0.516	1.890	119	125	3	1.011	3.700
82	63	6	1.025	3.750	120	125	6	2.038	7.460
83	63	10	1.721	6.300	121	125	10	3.361	12.300
84	63	16	2.773	10.150	122	125	12	4.057	14.850
85	70	4	0.754	2.760	123	125	16	5.355	19.600
86	70	10	1.858	6.800	124	125	20	6.645	24.320
87	70	19	3.634	13.300	125	126	6	2.068	7.570
88	70	29	4.733	17.323	126	140	12	4.497	16.460
89	75	3	0.612	2.240	127	146	3	1.221	4.470
90	75	5	1.025	3.750	128	150	3	1.202	4.400
91	75	6	1.216	4.450	129	150	5	2.049	7.500
92	75	8	1.639	6.000	130	150	6	2.437	8.920
93	75	10	2.055	7.520	131	150	8	3.142	11.500
94	75	12	2.377	8.700	132	150	10	4.112	15.050
95	75	16	3.268	11.960	133	150	12	4.836	17.700
96	75	20	4.060	14.860	134	150	16	6.445	23.590
97	75	25	5.055	18.500	135	150	20	8.197	30.000
98	75	50	10.219	37.400	136	150	25	10.123	37.050
99	75.5	5	1.024	3.750	137	152	6	2.492	9.120
100	80	4	0.861	3.150	138	154	51.8	21.530	78.800
101	80	6	1.284	4.700	139	160	6	2.404	8.800
102	80	10	2.131	7.800	140	160	10	4.344	15.900
103	80	12	2.574	9.420	141	160	12	5.178	18.950
104	80	20	4.372	16.000	142	175	6	2.768	10.130
105	80	25	5.402	19.770	143	175	10	4.781	17.500
106	100	3	0.820	3.000	144	175	12	5.683	20.800
107	100	4	1.087	3.980	145	180	10	4.918	18.000
108	100	5	1.339	4.900	146	200	3	1.639	6.000
109	100	6	1.585	5.800	147	200	6	3.265	11.950
110	100	8	2.093	7.660	148	200	10	5.402	19.770
111	100	10	2.678	9.800	149	200	12.5	6.803	24.900
112	100	12	3.183	11.650	150	200	14	7.557	27.660
113	100	16	4.358	15.950	151	200	16	8.642	31.630
114	114	100	20	5.451					



FLAT BAR (R)



SR.NO.	A	B	R	WT/M	WT/12FT
1	18.7	4.55	2.28	0.230	0.840
2	20	1.5	0.75	0.079	0.290
3	25	3	1.5	0.205	0.750
4	25	6	3	0.355	1.300
5	25	10	5	0.628	2.300
6	30	10	5	0.751	2.750
7	36.5	15	2	1.467	5.370
8	40	6	3	0.628	2.300
9	40	10	5	1.022	3.740
10	40	28	3	3.032	11.100
11	50	6	3	0.833	3.050
12	50	10	5	1.311	4.800
13	50	12	6	1.612	5.900
14	50	13	6.5	1.653	6.050
15	50	15	5	1.913	7.000
16	50	15	7.5	2.022	7.400
17	60	10	5	1.557	5.700
18	63.5	12.7	6.35	2.178	7.970
19	80	6	3	1.311	4.800
20	80	10	5	2.104	7.700
21	100	6	3	1.639	6.000
22	100	10	5	2.650	9.700
23	126	6	3	2.066	7.560
24	150	16	8	6.311	23.100
25	150	20	10	7.773	28.450
26	175	6	3	2.869	10.500
27	25.4	2.95	2	0.191	0.700
28	40	18	3	3.033	11.100
29	60	10	3	0.230	0.840
30	75	10	3	2.027	7.420
31	80	10	3	2.077	7.600
32	100	10	5	2.691	9.850
33	120	16	2	5.126	18.760
34	120	10	3	3.197	11.700
35	125	10	3	3.224	11.800
36	125	10	5	3.333	12.200
37	150	10	5	4.005	14.660
38	150	12	6	4.863	17.800
39	150	16	8	6.338	23.200
40	160	10	3	4.344	15.900
41	200	10	5	5.355	19.601



EQUAL ANGLE

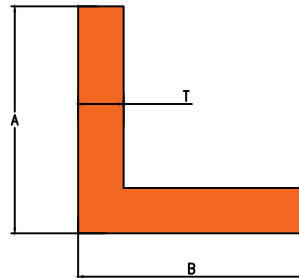

SR.NO.	A	B	T	WT/M	WT/12FT	SR.NO.	A	B	T	WT/M	WT/12FT
1	12	12	1.4	0.087	0.320	32	38	38	2	0.383	1.400
2	15	15	1.5	0.120	0.440	33	38	38	2.3	0.464	1.700
3	15	15	2	0.156	0.570	34	38	38	2.55	0.519	1.900
4	19	19	0.7	0.071	0.260	35	38	38	2.7	0.533	1.950
5	19	19	1.1	0.107	0.390	36	38	38	3.2	0.628	2.300
6	19	19	1.2	0.120	0.440	37	38	38	3.3	0.656	2.400
7	19	19	1.9	0.197	0.720	38	38	38	4	0.801	2.930
8	19	19	1.85	0.178	0.650	39	38	38	5	0.984	3.600
9	19	19	2	0.205	0.750	40	38	38	6	1.148	4.200
10	19	19	2.5	0.246	0.900	41	50	50	1.5	0.410	1.500
11	19	19	3	0.301	1.100	42	50	50	2	0.533	1.950
12	19	19	1.5	0.158	0.580	43	50	50	2.5	0.669	2.450
13	19.5	19.5	2.2	0.219	0.800	44	50	50	3	0.779	2.850
14	20	20	2	0.219	0.800	45	50	50	4	1.066	3.900
15	22	22	2.5	0.287	1.050	46	50	50	4.7	1.208	4.421
16	25	25	1.2	0.153	0.560	47	50	50	5	1.306	4.780
17	25	25	1.45	0.186	0.680	48	50	50	6	1.598	5.850
18	25	25	1.5	0.205	0.750	49	60	60	4	1.298	4.750
19	25	25	2	0.246	0.900	50	63	63	3	1.011	3.700
20	25	25	2.1	0.273	1.000	51	63	63	6	1.934	7.080
21	25	25	2.2	0.301	1.100	52	65	65	3	1.052	3.850
22	25	25	2.5	0.314	1.150	53	75	75	3	1.224	4.480
23	25	25	3	0.361	1.320	54	75	75	5	1.945	7.120
24	25	25	6.5	0.874	3.200	55	75	75	6	2.445	8.950
25	30	30	3	0.475	1.740	56	75	75	10	3.784	13.850
26	31	31	2	0.328	1.200	57	100	100	3	1.478	5.410
27	31	31	3	0.492	1.800	58	100	100	5	2.705	9.900
28	31	31	5	0.773	2.830	59	100	100	6	3.126	11.440
29	31	31	6	0.962	3.520	60	100	100	10	5.137	18.800
30	38	38	1.35	0.273	1.000	61	150	150	4.5	2.404	8.800
31	38	38	1.4	0.273	1.000						



UNEQUAL ANGLE

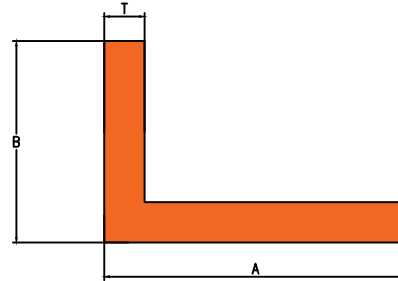

SR.NO.	A	B	T	WT/M	WT/12FT
1	17	15	1.5	0.128	0.470
2	19	12	1.5	0.115	0.420
3	25	9.5	1.75	0.156	0.570
4	25	15	2	0.219	0.800
5	25	16	2.5	0.238	0.870
6	25	19	2	0.224	0.820
7	30	15	2	0.232	0.850
8	35	22	2	0.301	1.100
9	38	25	5	0.779	2.850
10	38	25	3	0.464	1.700
11	38	25	2.5	0.396	1.450
12	38	25	2	0.314	1.150
13	38	25	1.6	0.273	1.000
14	38	25	1.5	0.246	0.900
15	40	20	3	0.486	1.780
16	50	25	4	0.792	2.900
17	50	25	3	0.590	2.160
18	55	35	2.2	0.511	1.870
19	58	25	2	0.448	1.640
20	63	50	6	1.733	6.342
21	65	25	3	0.642	2.350
22	75	50	2	0.669	2.450
23	75	50	4	1.339	4.900
24	75	50	3	0.940	3.440
25	85	50	6	1.967	7.200
26	80	50	5	1.749	6.400
27	100	50	6	2.322	8.500
28	100	50	5	2.063	7.550
29	100	50	3	1.2150	4.450
30	100	40	2.5	0.915	3.350
31	150	75	5	1.399	5.120
32	150	50	4.5	2.404	8.800



ROUND PIPE

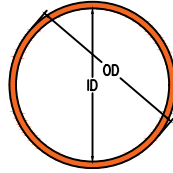

SR.NO.	OD	ID	WT/M	WT/12FT	SR.NO.	OD	ID	WT/M	WT/12FT
1	15.2	11.8	0.197	0.720	38	41	30	1.710	6.260
2	16.3	13.1	0.205	0.750	39	42	38	0.678	2.480
3	17	13	0.257	0.940	40	43	32	1.746	6.390
4	18	16.2	0.126	0.460	41	44.4	41.4	0.546	2.000
5	18	16.4	0.164	0.600	42	45	25	2.951	10.800
6	18.5	15.1	0.240	0.880	43	45	35	1.817	6.650
7	18.6	16.3	0.172	0.630	44	45	38	1.257	4.600
8	19	16.5	0.184	0.675	45	48	17	3.817	13.970
9	19.4	14.8	0.333	1.220	46	48	44	0.751	2.750
10	19.5	16.7	0.178	0.650	47	50	25	3.992	14.610
11	20	12	0.514	1.880	48	50	40	1.967	7.200
12	21	16	0.301	1.100	49	50	44	1.156	4.230
13	20	18	0.126	0.460	50	50	45.1	0.956	3.500
14	21.2	18.2	0.262	0.960	51	50	46	0.820	3.000
15	22	18	0.333	1.220	52	50.8	47.6	0.656	2.400
16	22.2	19.4	0.251	0.920	53	51	44	1.410	5.160
17	22.2	20.2	0.175	0.640	54	52	38	2.639	9.660
18	22.2	19.8	0.208	0.760	55	53	40	2.582	9.450
19	25	12	1.011	3.700	56	54	34	3.770	13.800
20	25	19	0.560	2.050	57	54	30	4.275	15.647
21	25	19	0.311	1.140	58	54.4	50	1.022	3.740
22	25	22	0.227	0.830	59	56	48.5	1.667	6.100
23	25.4	22.6	0.301	1.100	60	57	51	1.380	5.050
24	25.4	23.4	0.208	0.760	61	59.5	51	1.989	7.280
25	27	22	0.505	1.850	62	60	40	4.309	15.770
26	29	26.2	0.273	1.000	63	60	50	2.322	8.500
27	30	18	1.221	4.470	64	60	54	1.404	5.140
28	30	26	0.437	1.600	65	60	55	1.158	4.240
29	32	19	1.426	5.220	66	60	56	0.984	3.600
30	32	25	0.907	3.320	67	61	55	1.456	5.330
31	32	26	0.721	2.640	68	63	32	6.202	22.700
32	32	28	0.514	1.880	69	63	50	3.087	11.300
33	35	25	1.284	4.700	70	63	57	1.612	5.900
34	36	28	1.120	4.100	71	66	62	1.128	4.130
35	40	20	2.519	9.220	72	68.5	60.5	2.186	8.000
36	40	30	1.475	5.400	73	70	60	1.978	7.240
37	40	36	0.743	2.720	74	70	63	2.760	10.100



ROUND PIPE

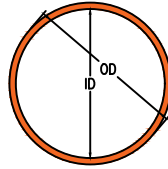

SR.NO.	OD	ID	WT/M	WT/12FT	SR.NO.	OD	ID	WT/M	WT/12FT
75	72	50	5.683	20.800	100	94	75	5.984	21.900
76	73	58	4.098	15.000	101	95	90	1.962	7.180
77	73	63	2.842	10.400	102	96	90	2.432	8.900
78	74	70	1.257	4.600	103	96.3	90.3	2.276	8.330
79	75	65	3.055	11.180	104	99	94	2.036	7.450
80	76	50	6.967	25.500	105	101	87	5.533	20.250
81	76	57	5.396	19.750	106	101	89	4.820	17.640
82	76	63	3.852	14.100	107	101	95	2.541	9.300
83	76	70	1.844	6.750	108	104	89	6.139	22.469
84	76	73	0.956	3.500	109	105	78	10.492	38.400
85	80	60	5.997	21.950	110	108	101	3.189	11.670
86	80	70	3.257	11.920	111	114	101	5.792	21.200
87	80	71.5	2.596	9.500	112	114	107	3.251	11.900
88	81	66	4.675	17.111	113	118	98	8.620	31.550
89	82	39	10.995	40.240	114	120	107	6.287	23.010
90	82	76	1.978	7.240	115	120	114	2.978	10.900
91	84.2	80	1.415	5.180	116	127	114	6.650	24.340
92	85	80	1.749	6.400	117	127	120	3.508	12.840
93	88	84	1.585	5.800	118	127	121.2	3.060	11.200
94	89	68	6.795	24.870	119	129	125	2.158	7.900
95	89	76	4.568	16.720	120	145	132.8	4.907	17.960
96	89	82	2.339	8.560	121	150	136	8.497	31.100
97	90	86	1.557	5.700	122	160	140	12.760	46.700
98	92	82	2.117	7.750	123	160	152	5.301	19.400
99	93.5	88.5	1.926	7.050					



ROUND BAR

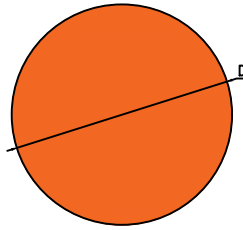

SR.NO.	D	WT/M	WT/12FT
1	8	0.137	0.500
2	10	0.205	0.750
3	12	0.314	1.150
4	15	0.792	2.900
5	16	0.327	1.198
6	19	0.779	2.850
7	20	0.847	3.100
8	27.2	1.995	7.300
9	31.7	2.145	7.850
10	38	3.063	11.210
11	42.5	3.825	14.000
12	71	10.683	39.100
13	80.4	13.689	50.100



SQUARE BAR

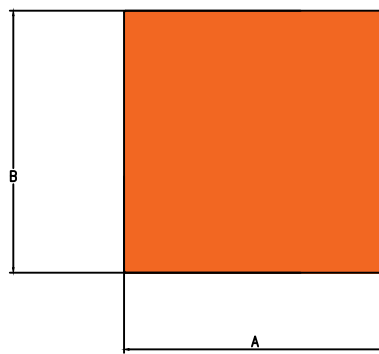

SR.NO.	A	B	WT/M	WT/12FT
1	8	8	0.171	0.625
2	9.5	9.5	0.246	0.900
3	12	12	0.451	1.900
4	16.3	16.3	0.724	2.900
5	22	22	1.311	3.900



SQUARE TUBE

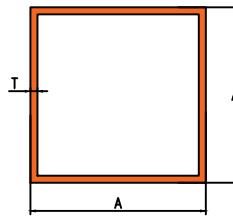

SR.NO.	A	T	WT/M	WT/12FT
1	12.7	1.5	0.180	0.660
2	15.0	1.5	0.221	0.810
3	19	1.2	0.232	0.850
4	19	1.5	0.284	1.040
5	19	2	0.369	1.350
6	25	1	0.257	0.940
7	25	1.5	0.383	1.400
8	25	2	0.495	1.810
9	25	3	0.710	2.600
10	30	2	0.614	2.250
11	30	3	0.874	3.200
12	31	2	0.628	2.300
13	31	2.5	0.765	2.800
14	31	3	0.915	3.350
15	34	1.5	0.505	1.850
16	38	1.1	0.437	1.600
17	38	1.3	0.492	1.800
18	38	1.5	0.601	2.200
19	38	1.7	0.669	2.450
20	38	2	0.792	2.900
21	38	2.5	0.970	3.550
22	38	3	1.161	4.250
23	40	2.6	1.052	3.850
24	40	3.0	1.202	4.400
25	40	4	1.544	5.650
26	45	2	0.902	3.300
27	50	0.95	0.503	1.840
28	50	1.15	0.601	2.200
29	50	1.25	0.656	2.400
30	50	1.5	0.779	2.850
31	50	2	1.052	3.850
32	50	2.5	1.284	4.700
33	50	3	1.544	5.650
34	50	4	2.049	7.500
35	60	2.5	1.598	5.850
36	60	4.0	2.431	8.900
37	63	2.0	1.338	5.900
38	63	2.5	1.680	6.150
39	75	2	1.628	5.960
40	75	2.5	1.954	7.150
41	75	3	2.404	8.800
42	75	5	3.858	14.120
43	85	2.1	1.885	6.900
44	100	2	2.131	7.800
45	100	2.5	2.678	9.800
46	100	3	3.169	11.600
47	100	4	4.207	15.400



RECTANGULAR TUBE

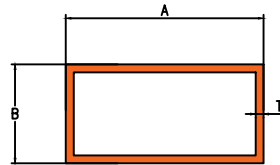

SR.NO.	A	B	T	WT/M	WT/12FT	SR.NO.	A	B	T	WT/M	WT/12FT
1	25	12	1.15	0.219	0.800	38	52.5	37.5	2	0.929	3.400
2	25	12	1.6	0.290	1.060	39	63	25	1	0.464	1.700
3	25	12	2	0.366	1.340	40	63	38	1	0.546	2.000
4	25	19	1	0.230	0.840	41	63	38	1.25	0.656	2.400
5	25	19	1.2	0.273	1.000	42	63	38	1.5	0.792	2.900
6	25	19	2	0.443	1.620	43	63	38	2	1.052	3.850
7	25	19	3.2	0.669	2.450	44	63	50	0.95	0.560	2.050
8	28	23	1.4	0.361	1.320	45	75	12	1.45	0.656	2.400
9	30	15	1.9	0.423	1.550	46	75	12	1.7	0.765	2.800
10	33	20	0.95	0.251	0.920	47	75	12	3.0	1.325	4.850
11	33	20	1.05	0.287	1.050	48	75	19	1	0.792	2.900
12	38	25	0.75	0.245	0.900	49	75	19	3	1.421	5.200
13	38	25	0.90	0.300	1.100	50	75	25	1	0.519	1.900
14	38	25	1.05	0.355	1.300	51	75	25	1.3	0.683	2.500
15	38	25	1.20	0.409	1.500	52	75	25	1.5	0.792	2.900
16	38	25	1.35	0.464	1.700	53	75	25	1.7	0.902	3.300
17	38	25	1.50	0.519	1.900	54	75	25	3	1.530	5.600
18	38	25	1.65	0.573	2.100	55	75	38	2	1.202	4.400
19	38	25	1.80	0.628	2.300	56	75	38	2.5	1.475	5.400
20	40	15	1.6	0.448	1.640	57	75	38	3	1.749	6.400
21	40	20	2.1	0.634	2.320	58	75	50	1.5	0.997	3.650
22	50	25	0.75	0.273	1.000	59	75	50	1.8	1.189	4.350
23	50	25	0.9	0.328	1.200	60	75	50	2	1.325	4.850
24	50	25	1	0.383	1.400	61	75	50	2.5	1.626	5.950
25	50	25	1.5	0.546	2.000	62	75	50	3	1.954	7.150
26	50	25	2	0.738	2.700	63	75	50	4	2.541	9.300
27	50	25	3	1.079	3.950	64	75	50	5	3.115	11.400
28	50	10	2	0.601	2.200	65	80	40	4	2.431	8.900
29	50	12	1.5	0.464	1.700	66	80	40	5	2.978	10.900
30	50	19	1.4	0.464	1.700	67	83	38	1	0.656	2.400
31	50	38	1.25	0.574	2.100	68	83	38	1.25	0.792	2.900
32	50	38	1.45	0.669	2.450	69	83	38	1.7	1.066	3.900
33	50	38	1.7	0.770	2.820	70	83	38	3	1.872	6.850
34	50	38	2	0.915	3.350	71	100	12	2.1	1.230	4.500
35	50	38	2.5	1.134	4.150	72	100	19	1.55	0.984	3.600
36	50	38	3	1.339	4.900	73	100	19	2	1.230	4.500
37	52.5	49.5	2	1.000	3.900	74	100	24	0.9	0.601	2.200



RECTANGULAR TUBE

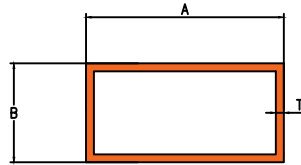

SR.NO.	A	B	T	WT/M	WT/12FT	SR.NO.	A	B	T	WT/M	WT/12FT
75	100	24	1.2	0.792	2.900	107	125	75	2	2.131	7.800
76	100	24	1.75	1.148	4.200	108	125	100	2.1	2.514	9.200
77	100	24	2.6	1.694	6.200	109	150	25	1.5	1.393	5.100
78	100	24	3.0	1.940	7.100	110	150	25	2.1	1.940	7.100
79	100	38	1.1	0.792	2.900	111	150	38	1.5	1.503	5.500
80	100	38	1.6	1.148	4.200	112	150	38	2	1.995	7.300
81	100	38	2	1.421	5.200	113	150	50	2	2.117	7.750
82	100	38	3	2.186	8.000	114	150	50	2.5	2.637	9.650
83	100	44	2.1	1.585	5.800	115	150	50	2.7	2.868	10.500
84	100	44	2.8	2.104	7.700	116	150	50	3	3.142	11.500
85	100	50	1.35	1.093	4.000	117	150	50	5	5.300	19.400
86	100	50	1.6	1.284	4.700	118	150	75	2	2.432	8.900
87	100	50	2	1.585	5.800	119	150	75	3	3.607	13.200
88	100	50	2.5	1.967	7.200	120	150	75	4	4.699	17.200
89	100	50	3	2.350	8.600	121	150	100	2	2.677	9.800
90	100	50	5	3.852	14.100	122	200	50	2	2.677	9.800
91	100	75	2	1.858	6.800						
92	100	75	3	2.760	10.100						
93	101.5	44.5	2	1.544	5.650						
94	115	65	2	1.913	7.000						
95	115	65	3	2.841	10.400						
96	117	25	1.3	1.011	3.700						
97	120	53	3	2.760	10.100						
98	125	25	1.2	0.929	3.400						
99	125	25	1.45	1.148	4.200						
100	125	25	1.65	1.311	4.800						
101	125	25	2.1	1.694	6.200						
102	125	25	2.6	2.049	7.500						
103	125	38	1.2	1.038	3.800						
104	125	38	1.45	1.257	4.600						
105	125	38	1.6	1.393	5.100						
106	125	50	2.2	2.022	7.400						



Darshan Extrusions Pvt. Ltd.

Die No. 16187

0.573 Kg/m
0.683 Kg/m
0.792 Kg/m

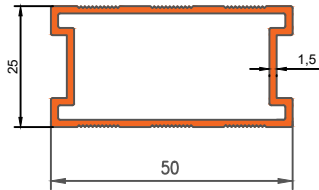

Die No. 9616

0.683 Kg/m
0.765 Kg/m
0.928 Kg/m

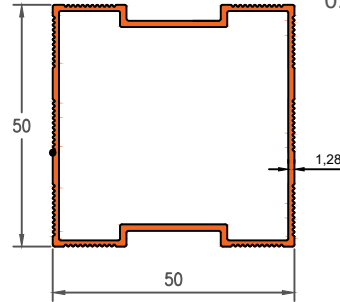

Die No. 16127

0.683 Kg/m
0.792 kg/m
0.956 kg/m

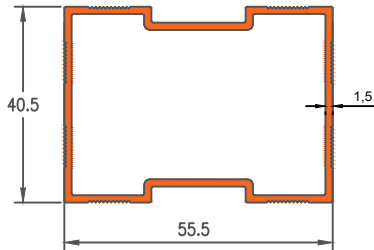

Die No. 16188

0.956 Kg/m
1.065 Kg/m

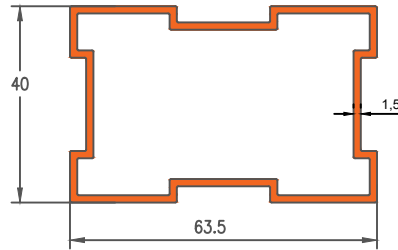

Die No. 16163

1.092 Kg/m
0.956Kg/m
1.338 kg/m

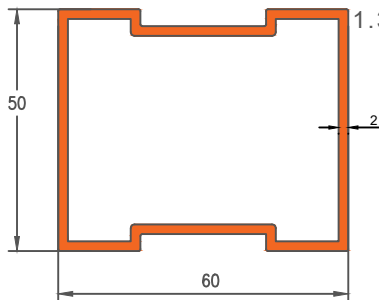

Die No. 9617

0.683 Kg/m

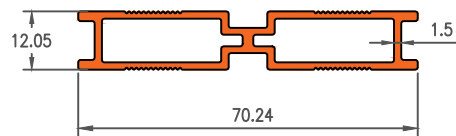

Die No. 16130

0.737 Kg/m
0.792 kg/m

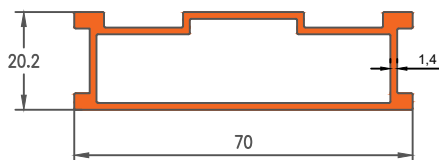

Die No. 16128

0.792 Kg/m
0.901 kg/m

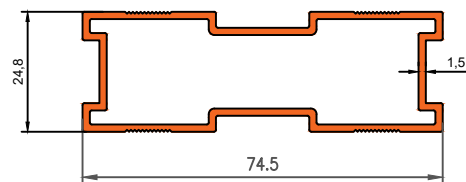

SLOTTED TUBES



Darshan Extrusions Pvt. Ltd.

Die No. 16161

0.956 Kg/m
1.065 kg/m
1.420 kg/m

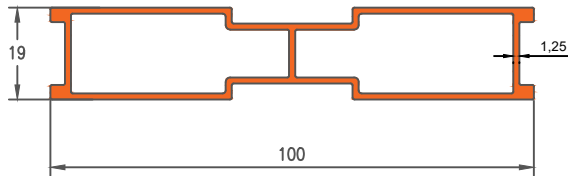

Die No. 16129

1.010 Kg/m
1.174 kg/m

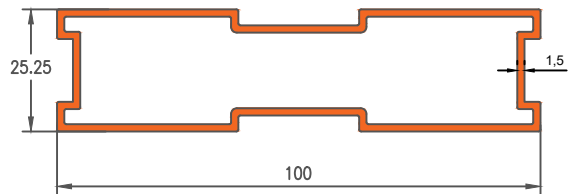

Die No. 19949

1.420 Kg/m

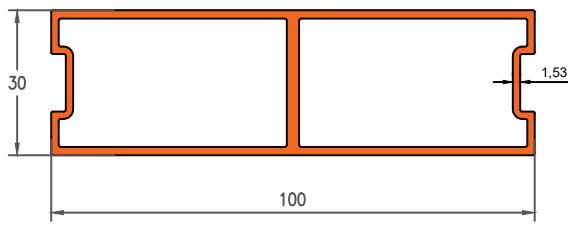

Die No. 1307

1.495 kg/m

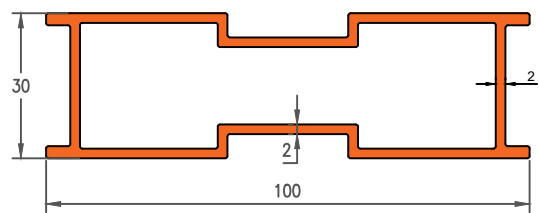

Die No. 19708

1.091 Kg/m

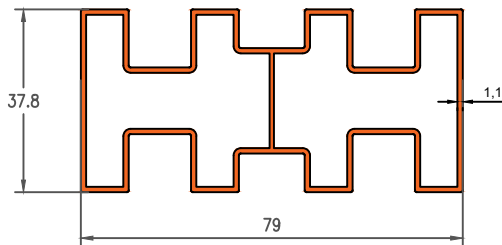

Die No. 21014

1.439 kg/m

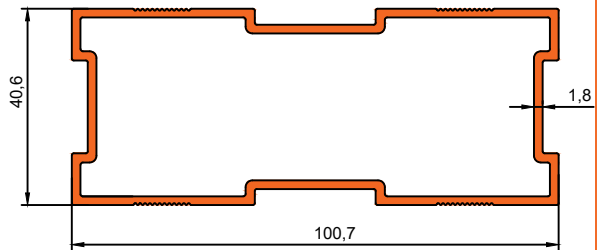

Die No. 21015

1.429 Kg/m

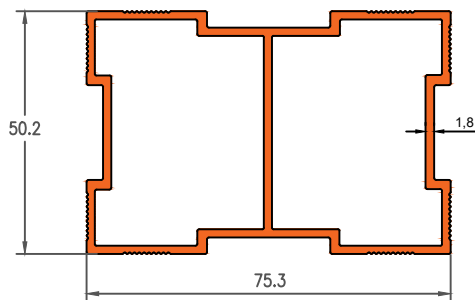

Die No. 21016

1.199 kg/m

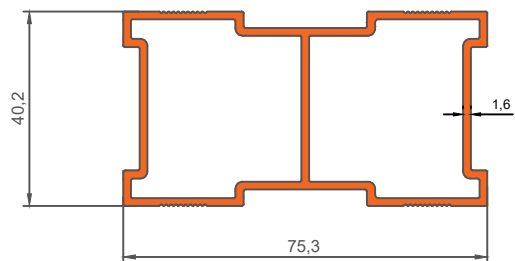

SLOTTED TUBE



Darshan Extrusions Pvt. Ltd.

Die No. 21017

0.516 Kg/m

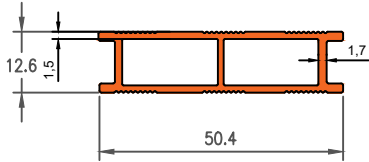

Die No. 21030

0.778 Kg/m

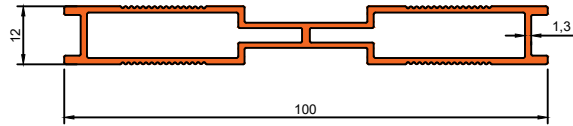

Die No. 21031

0.506 Kg/m

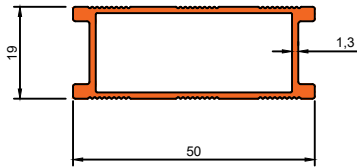

SLOTTED TUBE



U /C CHANNEL

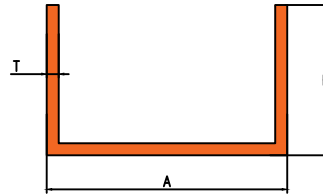

SR.NO.	A	B	T	WT/M	WT/12FT
1	9	9	0.8	0.055	0.200
2	9.6	15.3	1.15	0.115	0.420
3	9.9	10	0.9	0.093	0.340
4	10	15.3	1	0.117	0.430
5	10	16	1	0.109	0.400
6	12	12	0.6	0.057	0.210
7	12	12	1.2	0.115	0.420
8	12	15.45	2	0.213	0.780
9	15	15	1	0.120	0.440
10	15	12	1.7	0.115	0.420
11	15	15	2.25	0.251	0.920
12	18	14	1.2	0.142	0.520
13	19	12	1.5	0.123	0.450
14	20	20	1.4	0.205	0.750
15	20	25	2	0.355	1.300
16	25	12	1.1	0.150	0.550
17	25	12	1.95	0.246	0.900
18	25	25	2.5	0.478	1.750
19	31	15	1.1	0.178	0.650
20	33	50	3	1.025	3.750
21	35	13	1	0.150	0.550
22	38	12	1	0.150	0.550
23	38	19	3	0.601	2.200
24	38	19	4	0.702	2.570
25	38	25	2	0.437	1.600
26	38	50	4	1.393	5.100
27	40	40	3	0.899	3.290
28	45	25	3	0.738	2.700
29	45	25	4	0.937	3.430
30	50	25	1.2	0.317	1.160
31	50	25	3	0.760	2.780
32	50	25	6	1.410	5.160
33	50	50	3	1.148	4.200
34	75	38	6	2.240	8.200
35	100	50	5	2.705	9.900
36	100	50	6	3.019	11.050
37	100	50	8	3.940	14.420
38	150	50	6	3.798	13.900



T- SECTION

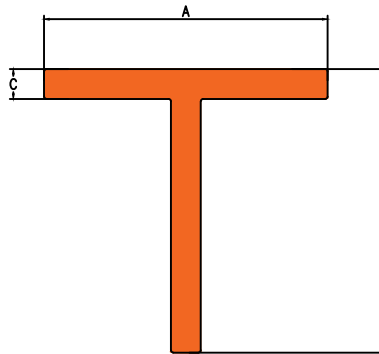

SR.NO.	A	B	T	WT/M	WT/12FT
1	12	12	2	0.117	0.430
2	19	19	0.9	0.085	0.310
3	19	19	1.7	0.161	0.590
4	20	30	1.2	0.158	0.580
5	25	25	1.15	0.148	0.540
6	25	25	1.5	0.191	0.700
7	31	31	2.5	0.399	1.460
8	38	38	4	0.765	2.800
9	50	50	2.35	0.628	2.300
10	75	50	2.5	0.847	3.100



E-SECTION

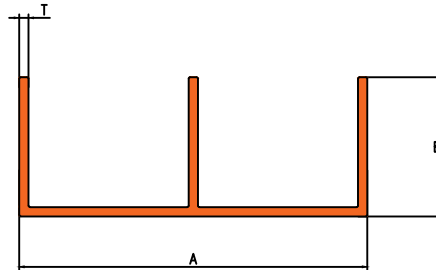

SR.NO.	A	B	T	WT/M	WT/12FT
1	15	12	0.75	0.090	0.330
2	19	12	0.6	0.074	0.270
3	19	12	1	0.150	0.550
4	21	14	0.9	0.153	0.560
5	22	12	0.6	0.090	0.390
6	22	12	1	0.150	0.550
7	22	12	1.15	0.175	0.640
8	25	12	0.95	0.154	0.565
9	31	15	1.4	0.273	1.000



Die No. 1531 0.900 KG/12FT

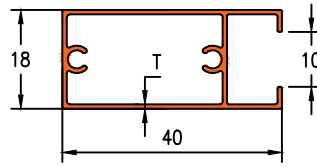
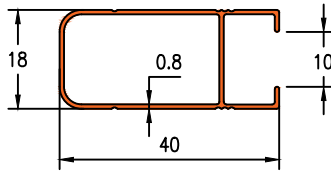

Die No.	T	W / 12FT
1571	0.75	0.900-1.000
1571	0.85	1.000-1.200
1571	1.0	1.200-1.400
1571	1.20	1.400-1.600
1571	1.30	1.600-1.800
1571	1.45	1.800-2.000

Die No. 1532 1.250 KG/12FT

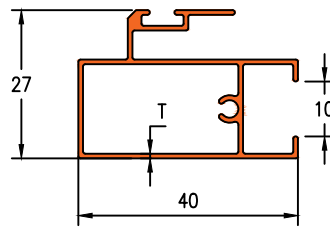
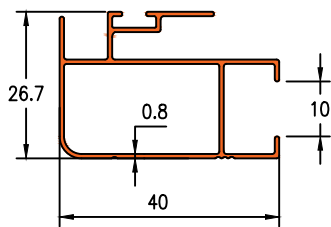

Die No.	T	W / 12FT
19825	0.75	1.200-1.400
19825	1.0	1.400-1.600
19825	1.15	1.600-1.800
19825	1.25	1.800-2.000

Die No. 1552 1.400 KG/12FT

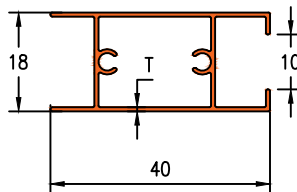
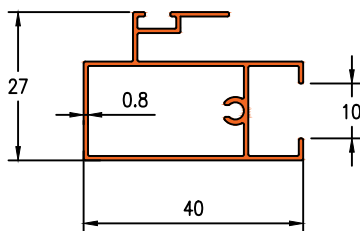

Die No.	T	W / 12FT
1592	0.75	0.900-1.000
1592	0.85	1.000-1.200
1592	1.0	1.200-1.400
1592	1.2	1.400-1.600
1592	1.3	1.600-1.800
1592	1.45	1.800-2.000

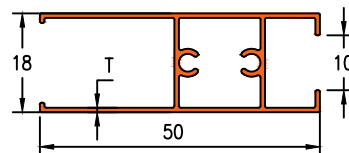
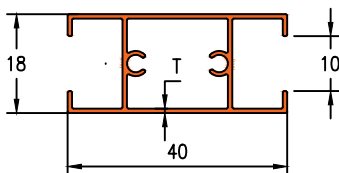

Die No.	T	W / 12FT
1593	0.80	1.000 - 1.200
1593	0.95	1.200 - 1.400

Die No.	T	W / 12FT
1631	0.8	1.200-1.400
1631	0.95	1.400-1.600
1631	1.05	1.600-1.800
1631	1.20	1.800-2.000

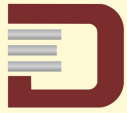

Die No. 1525

2.200 KG/12FT
1.800 KG/12FT

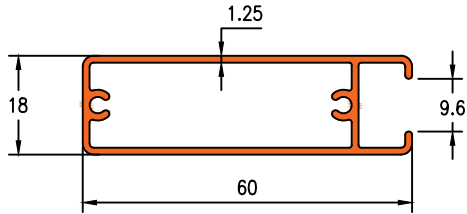

Die No. 22023

2.200 KG/12FT

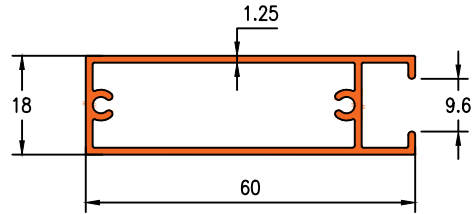

Die No. 1526

1.900 KG/12FT

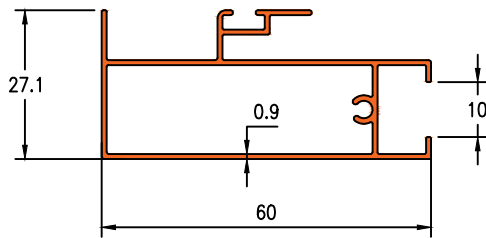

Die No. 22024

2.400 KG/12FT

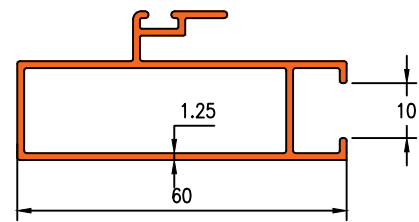

Die No. 1527

2.200 KG/12FT
1.800 KG/12FT

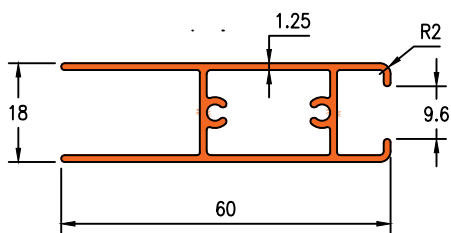

Die No. 22025

1.800 KG/12FT

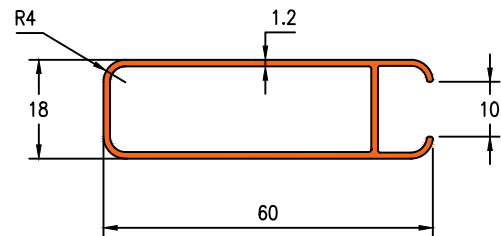

Die No. 16142

2.150 KG/12FT

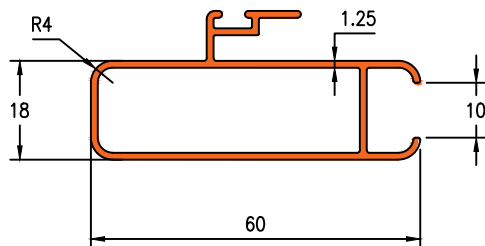

Die No. 16133

1.800 KG/12FT

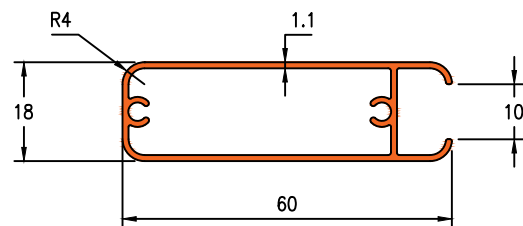

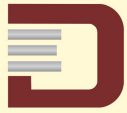

Die No. 1533

1.950 KG/12FT

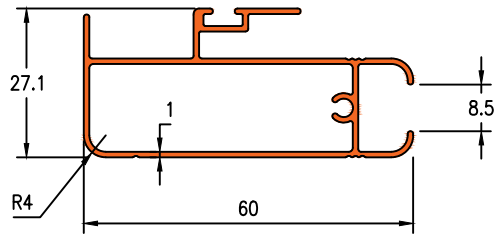

Die No. 1534

1.600 KG/12FT

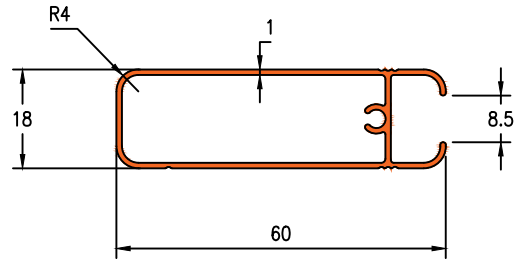

Die No. 1528

1.500 KG/12FT

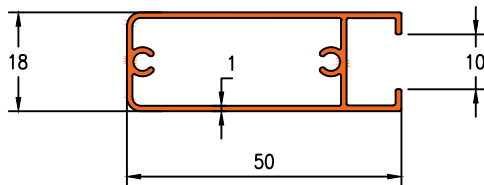

Die No. 1529

1.610 KG/12FT

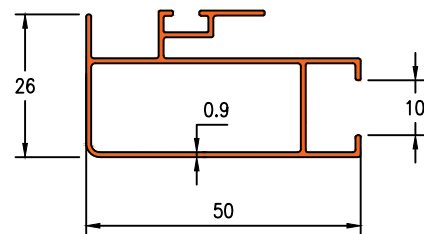

Die No. 1505

1.560 KG/12FT

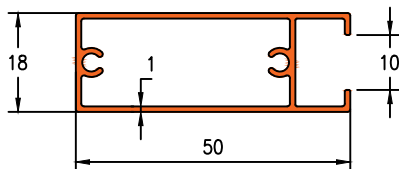

Die No. 1501

1.550 KG/12FT

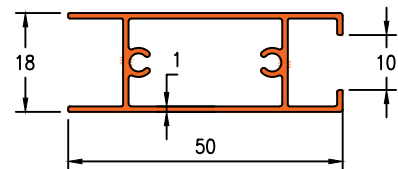

Die No. 1530

1.620 KG/12FT

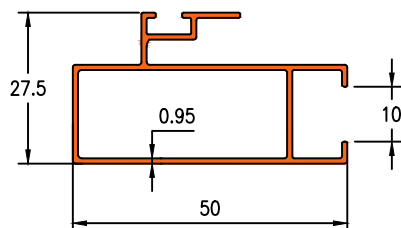



Die No. 1101

0.950 KG/12FT

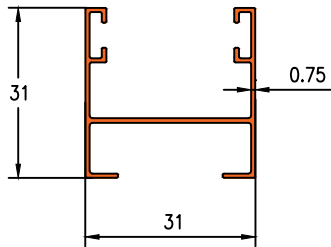

Die No. 1102

1.080 KG/12FT

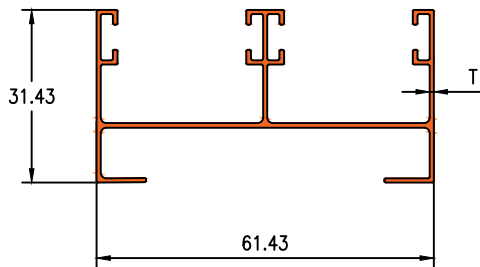
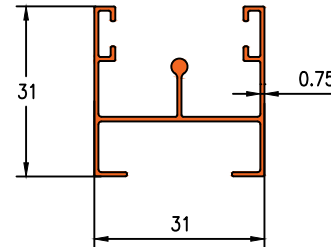

Die No.	T	W / 12FT
19462	0.65	1.200-1.400
19462	0.75	1.400-1.600
19462	0.85	1.600-1.800
19462	0.95	1.800-2.000
19462	1.05	2.000-2.200
19462	1.55	3.000-3.200

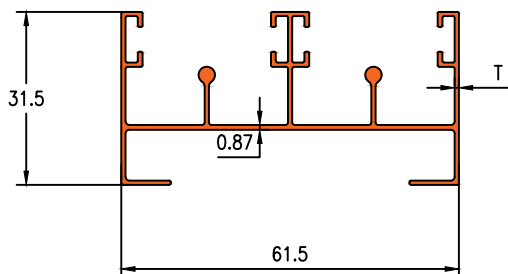

Die No.	T	W / 12FT
19461	0.65	1.400-1.600
19461	0.75	1.600-1.800
19461	0.85	1.800-2.000
19461	0.95	2.200-2.400
19461	1.55	3.400-3.600

Die No. 20015

1.400 KG/12FT

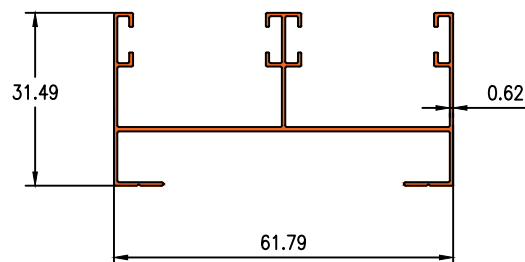

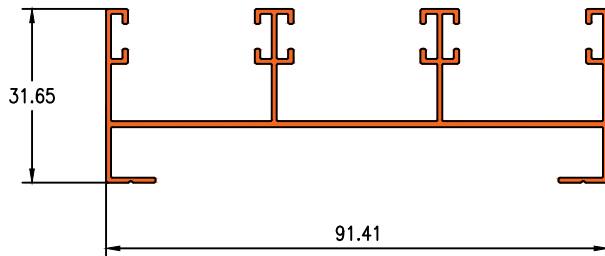
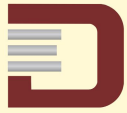

Die No.	T	W / 12FT
19464	0.65	1.600-1.800
19464	0.70	1.800-2.000
19464	0.80	2.200-2.400
19464	0.90	2.400-2.600
19464	1.00	2.600-2.800
19464	1.10	2.800-3.000
19464	1.20	3.000-3.200
19464	1.30	3.500-3.700
19464	1.55	4.200-4.400

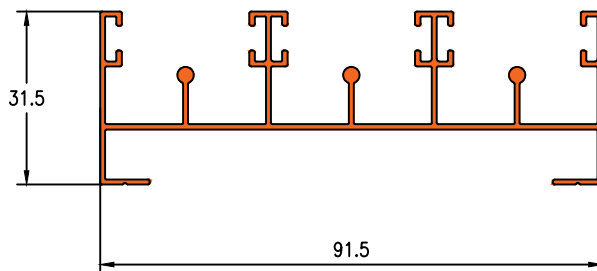

Die No.	T	W / 12FT
19463	0.70	2.200-2.400
19463	0.80	2.400-2.600
19463	0.85	2.600-2.800
19463	0.90	2.800-3.000
19463	1.00	3.000-3.200
19463	1.15	3.600-3.800
19463	1.25	3.800-4.000
19463	1.55	4.700-4.900

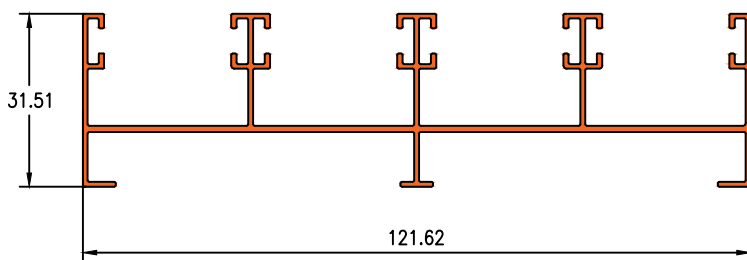

Die No.	T	W / 12FT
1150	0.85	2.800-3.000
1150	0.90	3.000-3.200
1150	0.95	3.200-3.400
1150	1.00	3.400-3.600
1150	1.05	3.600-3.800
1150	1.20	4.100-4.300
1150	1.55	5.300-5.500

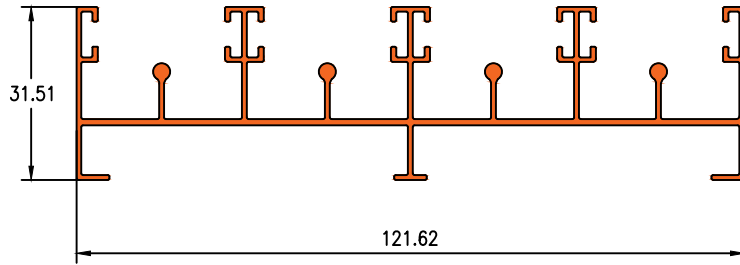

Die No.	T	W / 12FT
1162	0.85	3.400-3.600
1162	0.90	3.600-3.800
1162	0.95	3.800-4.000
1162	1.00	4.100-4.300
1162	1.15	4.600-4.800
1162	1.55	6.100-6.300

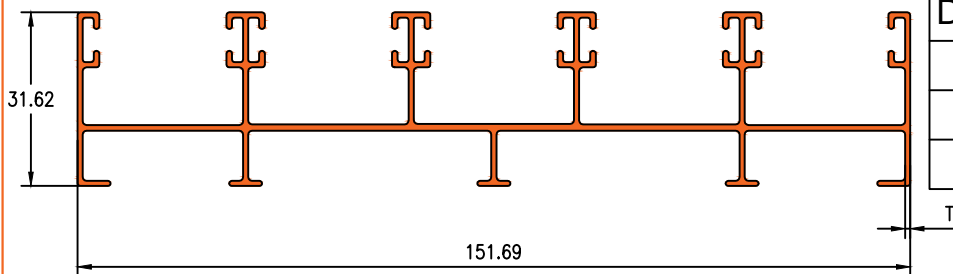

Die No.	T	W / 12FT
1167	0.80	3.800-4.000
1167	0.90	4.300-4.600
1167	1.10	5.300-5.600

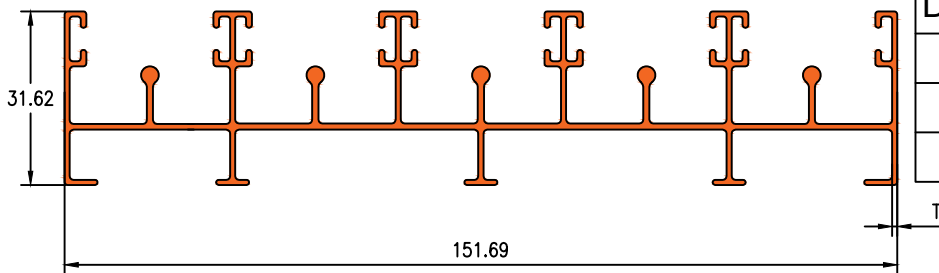

Die No.	T	W / 12FT
1168	0.85	4.600-4.800
1168	0.90	5.000-5.200
1168	1.10	6.000-6.200

Die No. 22093

0.739 KG/M

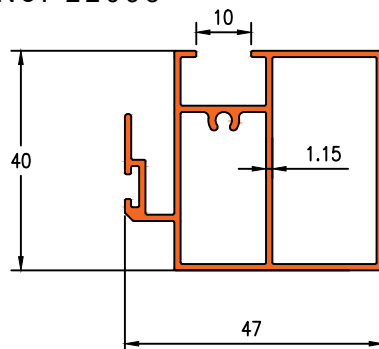



Die No. 16091

3.280 KG/12FT

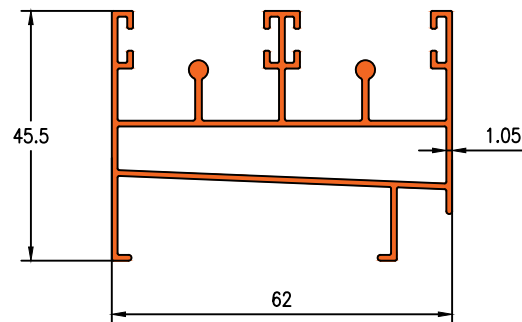

Die No. 16092

1.260 KG/12FT

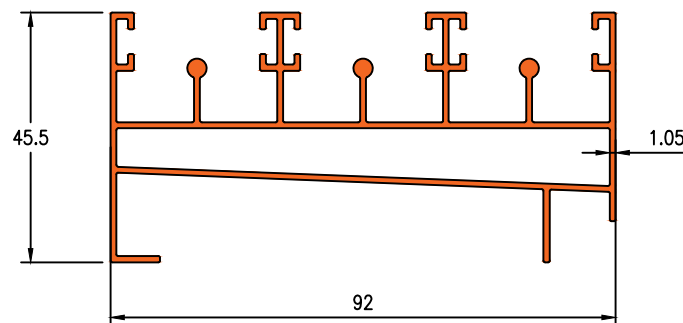

Die No. 3003

3.350 KG /12FT

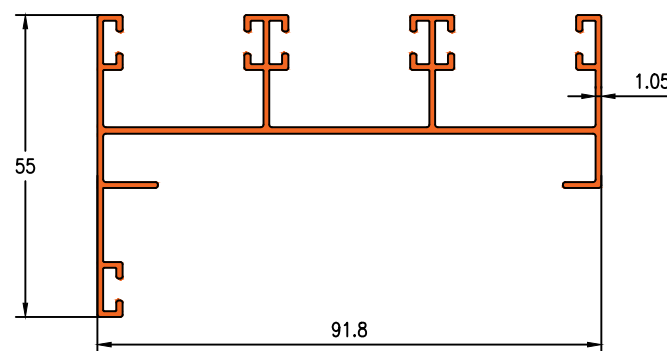

Die No. 19905

6.130 KG/12FT

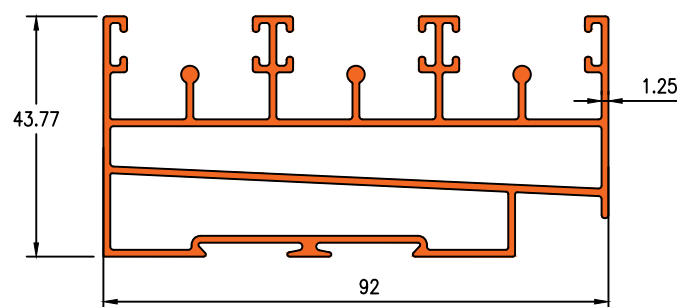



Enq No. 1569

0.787 Kg/m

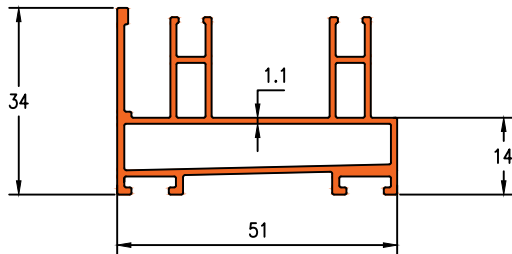

Enq No. 1570

1.095 Kg/m

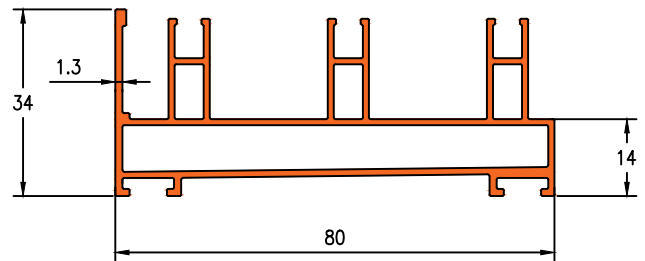

Enq No. 1566

0.443 Kg/m

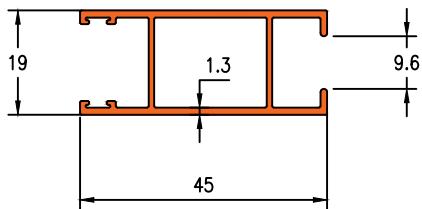

Enq No. 1567

0.339 Kg/m

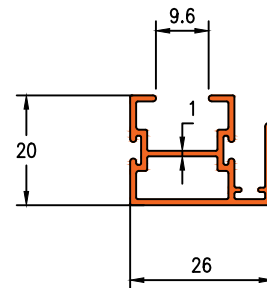

Enq No. 1568

0.555 Kg/m

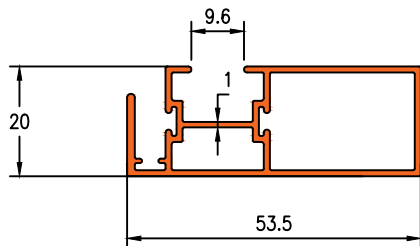

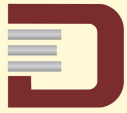

Die No. 16035

1.830 KG/12FT

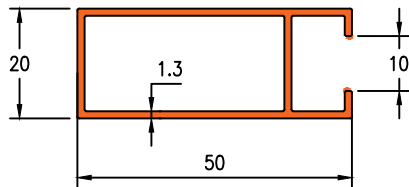

Die No. 16027

2.040 KG/12FT

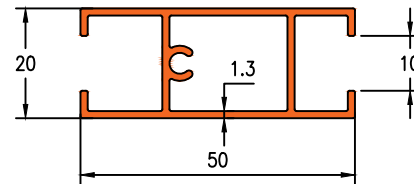

Die No. 16028

2.160 KG/12FT

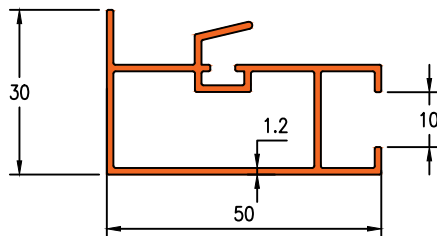

Die No. 16029

1.650 KG/12FT

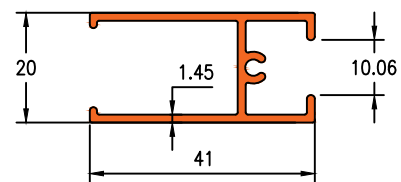

Die No. 16031

2.250 KG/12FT

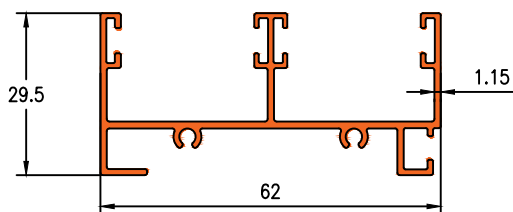

Die No. 16030

2.670 KG/12FT

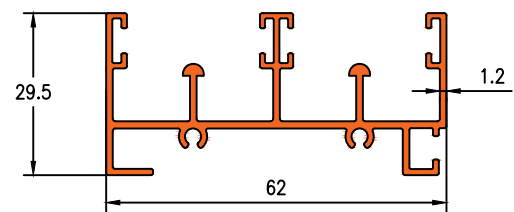

Die No. 16032

2.880 KG/12FT

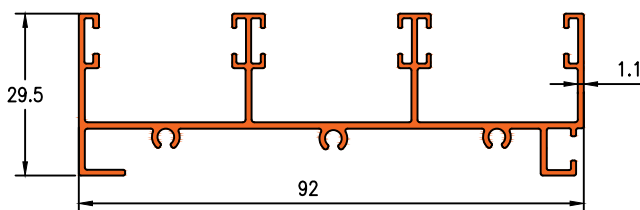

Die No. 16033

3.619 KG/12FT

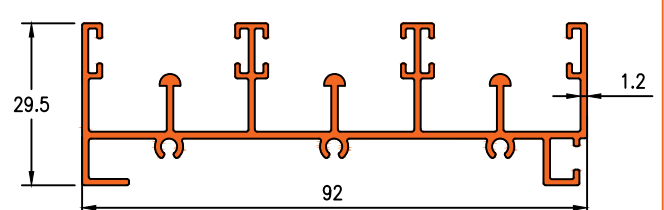

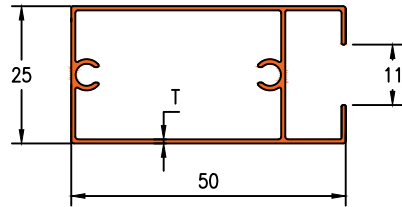
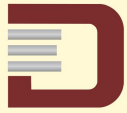

Die No.	T	W / 12FT
1611	0.80	1.400-1.600
1611	0.95	1.600-1.800
1611	1.05	1.800-2.000
1611	1.20	2.000-2.200
1611	1.30	2.200-2.400
1611	1.40	2.400-2.600

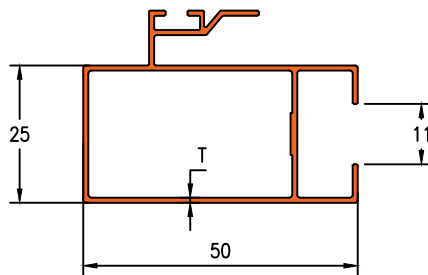

Die No.	T	W / 12FT
1615	0.95	1.800-2.000
1615	1.05	2.000-2.200
1615	1.15	2.200-2.400
1615	1.25	2.400-2.600
1615	1.45	2.800-3.000

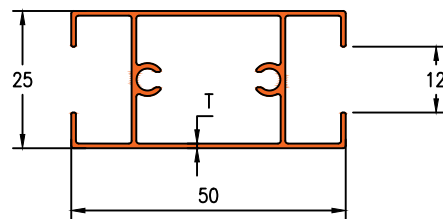

Die No.	T	W / 12FT
1612	0.90	1.600-1.800
1612	1.00	1.800-2.000

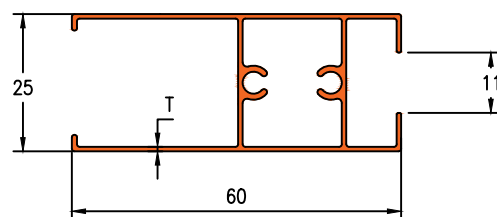

Die No.	T	W / 12FT
1621	0.95	1.800-2.00
1621	1.05	2.000-2.200
1621	1.15	2.200-2.400
1621	1.20	2.400-2.600
1621	1.30	2.600-2.800
1621	1.40	2.800-3.000



Die No. 16026

2.510 KG/12FT

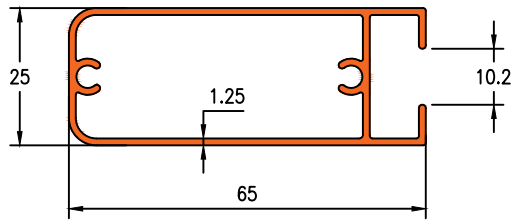

Die No. 1340

2.750 KG/12FT

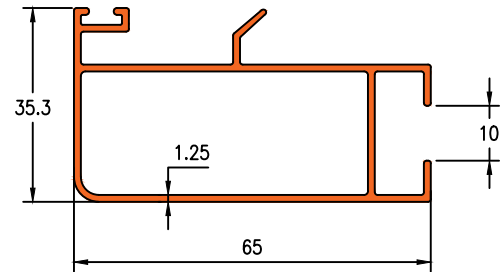

Die No. 1340M

2.450 KG/12FT

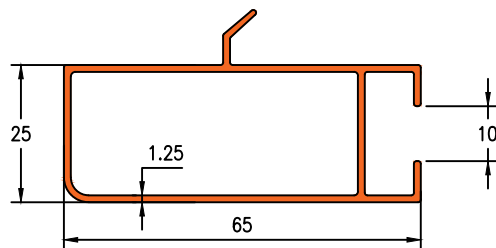

Die No. 1339

2.870KG/12FT

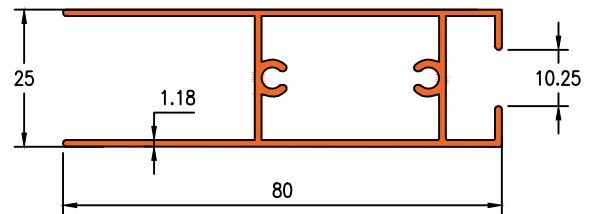

Die No. 1341

2.570 KG/12FT

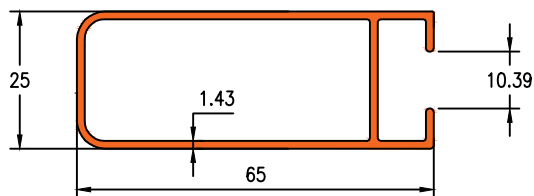

Die No. 16165

2.780 KG/12FT

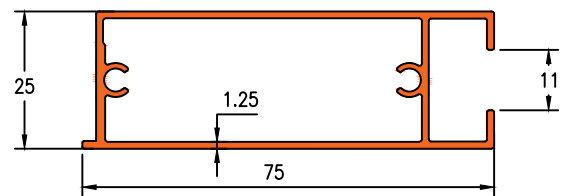

Die No. 16166

2.940 KG/12FT

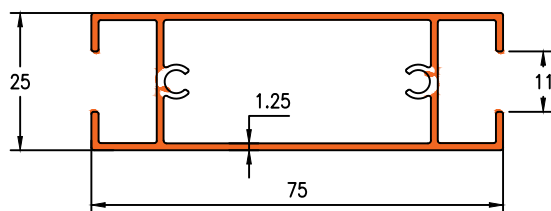

Die No. 10059

2.490 KG/12FT

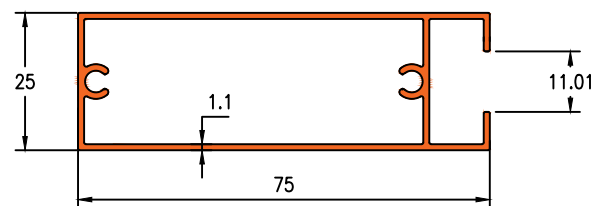



Die No. 21136

3.000 KG/12FT

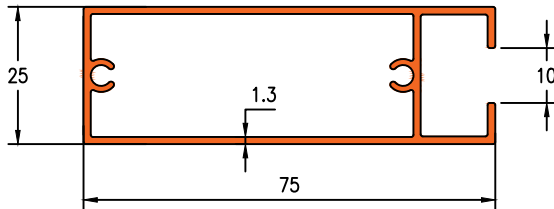

Die No. 21137

3.000 KG/12FT

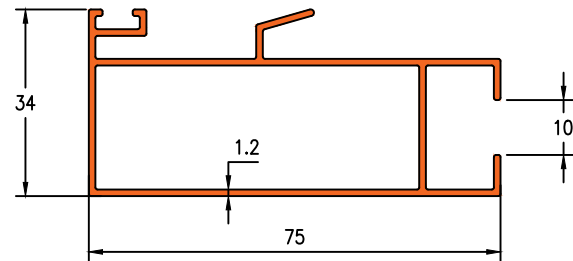

Die No. 21138

3.100 KG/12FT

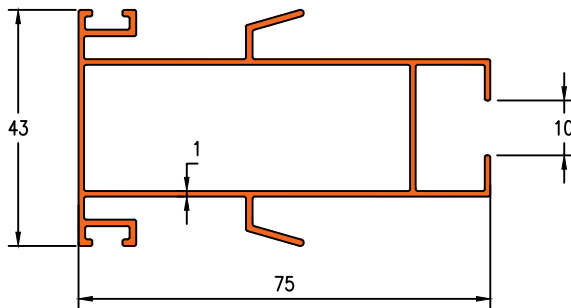

Die No. 21139

3.000 KG/12FT

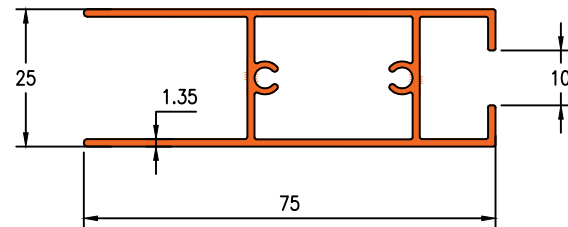

Die No. 21140

1.500 KG/12FT

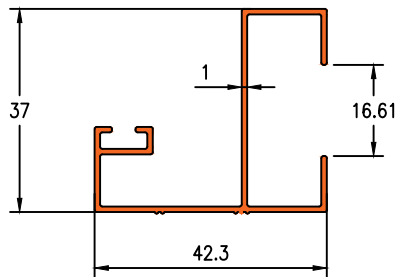

Die No. 21141

0.800 KG/12FT

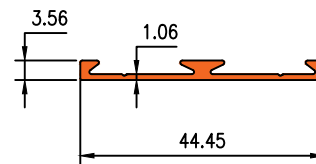

Die No. 21143

1.500 KG/12FT

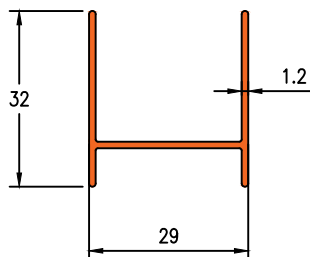



Die No. 16229

1.860 KG/12FT
1.400 KG/12FT

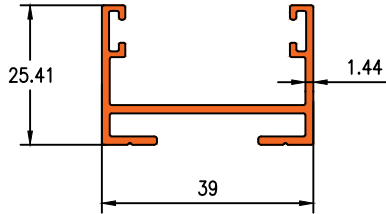

Die No. 16230

1.860 KG/12FT
1.500 KG/12FT

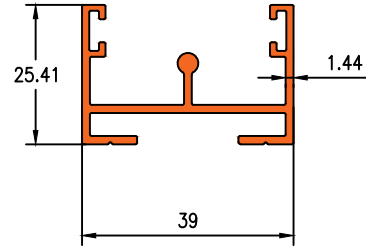

Die No. 1151

2.090 KG/12FT

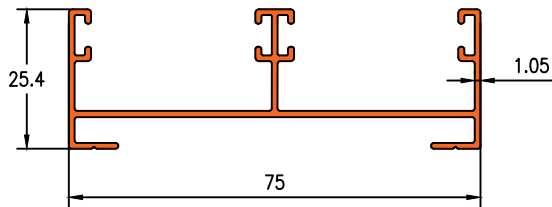

Die No. 1156

2.300 KG/12FT

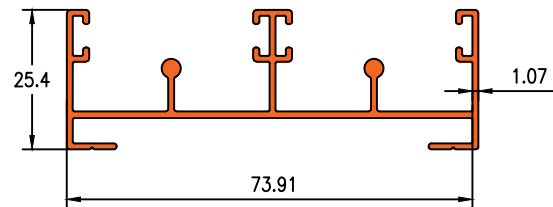

Die No. 1161

3.100 KG/12FT
3.340 KG/12FT
3.700 KG/12FT

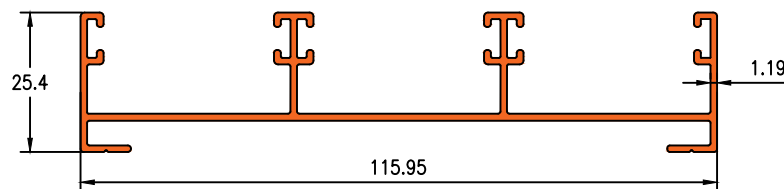

Die No. 1166

3.560 KG/12FT
4.000 KG/12FT

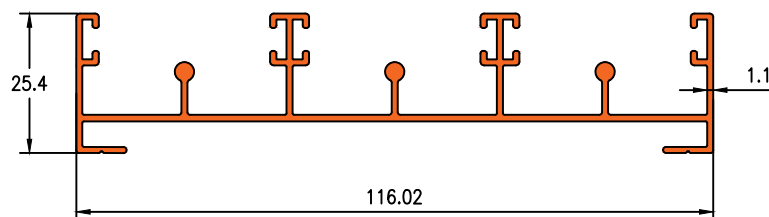

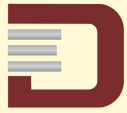

Die No. 16080

4.200 KG/12FT
4.800 KG/12FT

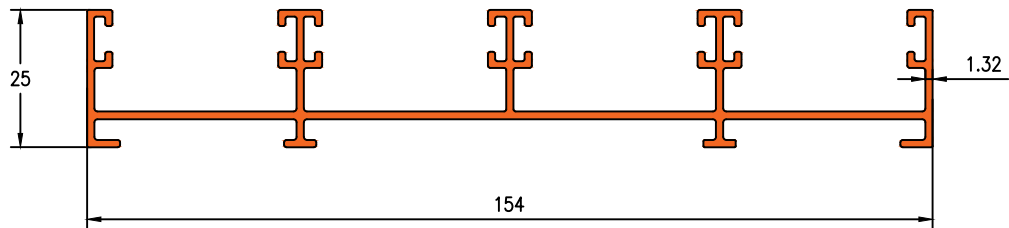

Die No. 16081

5.215 KG/12FT
6.100 KG/12FT

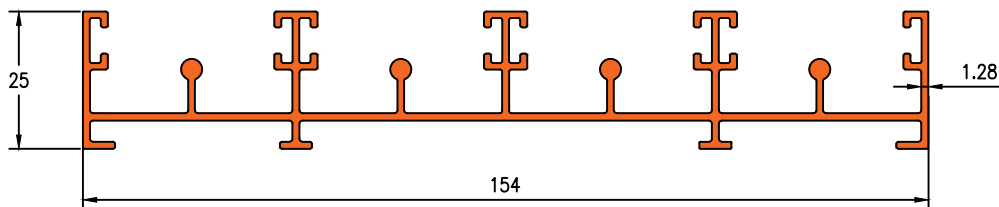

Die No. 16146

6.200 KG/12FT

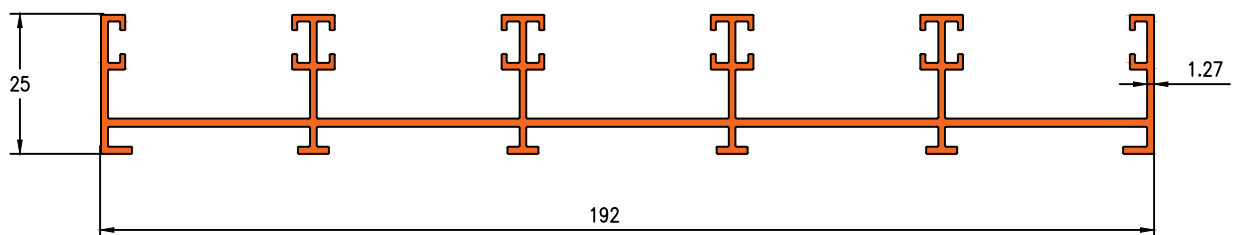

Die No. 16147

7.300 KG/12FT

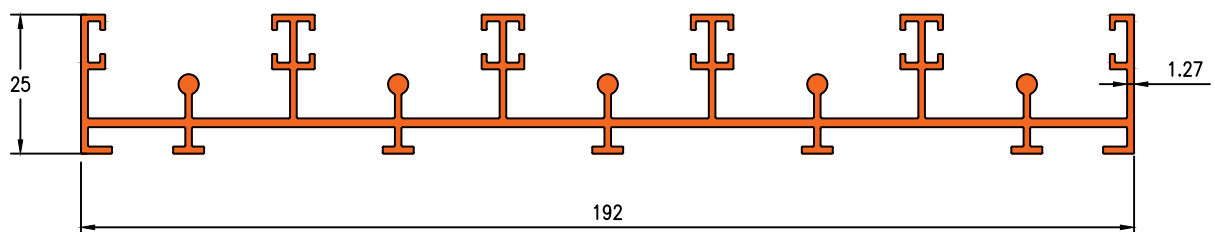



Die No. 19459

3.870 KG/12FT

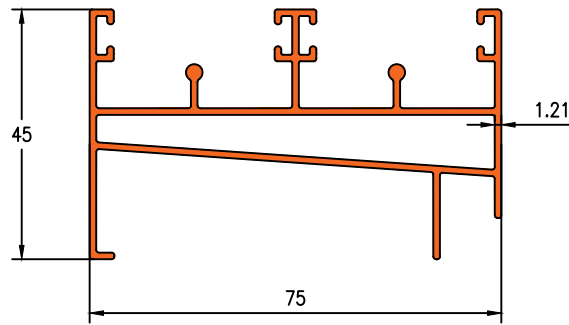

Die No. 19426

5.930 KG/12FT

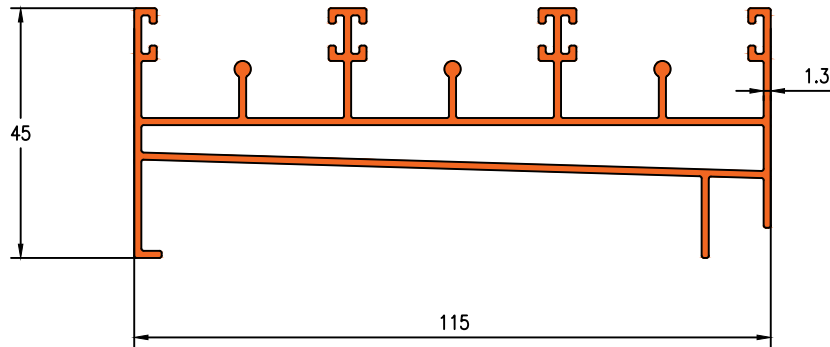

Die No. 19820

5.280 KG/12FT

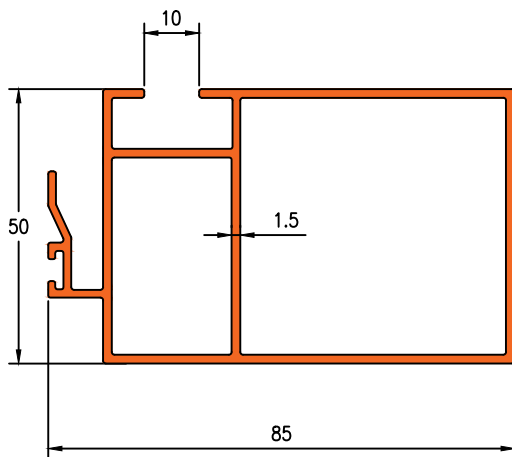



Die No. 30001

0.819KG/M

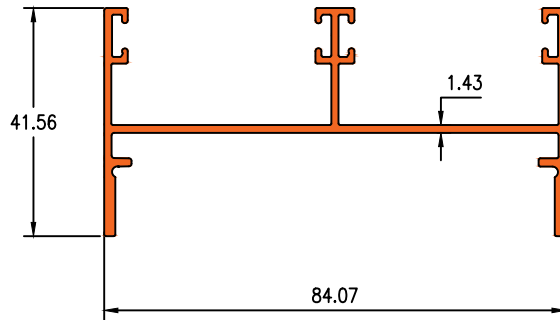

Die No. 30002

1.333KG/M

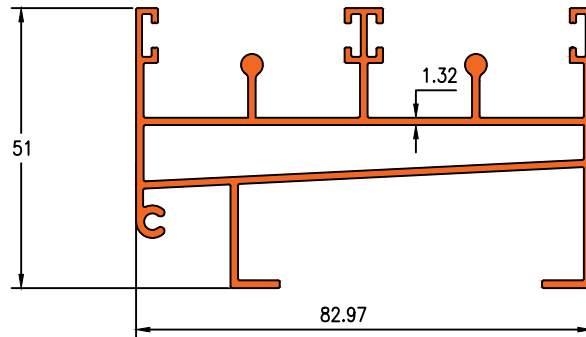

Die No. 30003

1.085KG/M

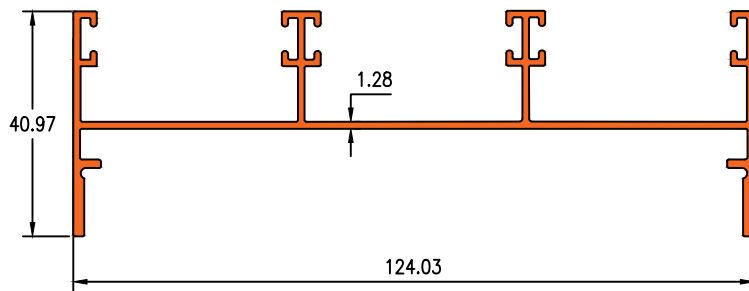

Die No. 30004

1.819KG/M

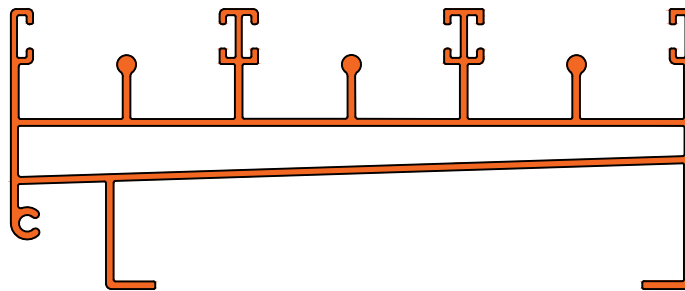



Die No. 30005

0.718 KG/M

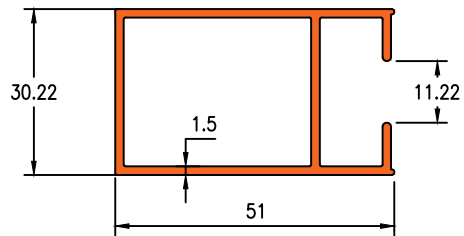

Die No. 30006

0.834KG/M

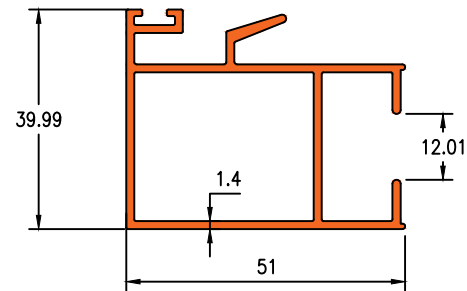

Die No. 30007

0.709KG/M

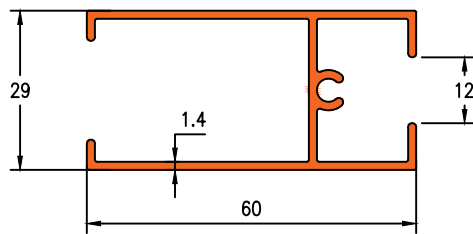

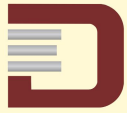

Die No. 16189

0.542KG/M

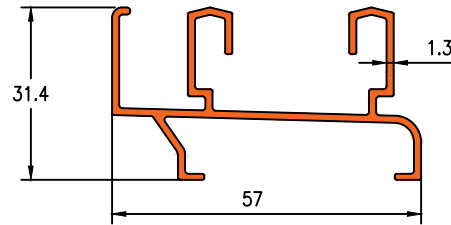

Die No. 16190

0.839KG/M

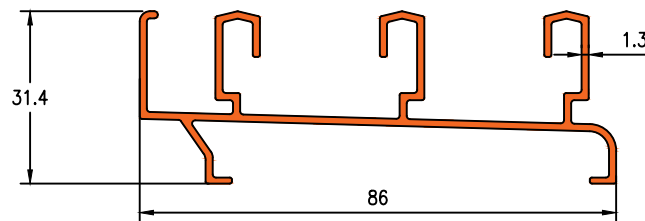

Die No. 16191

1.121KG/M

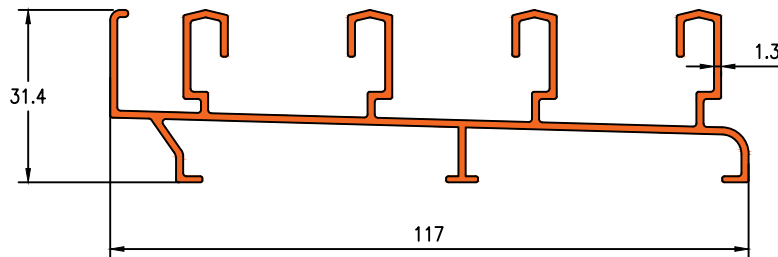

Die No. 16183

0.849KG/M

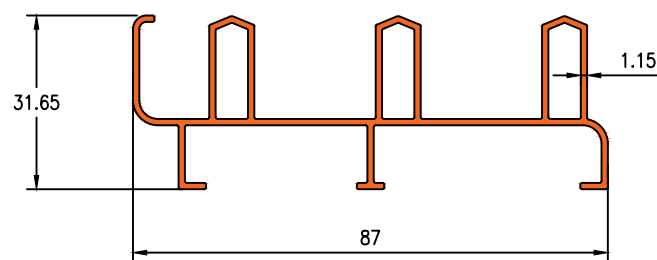



Die No. 16527

0.757KG/M

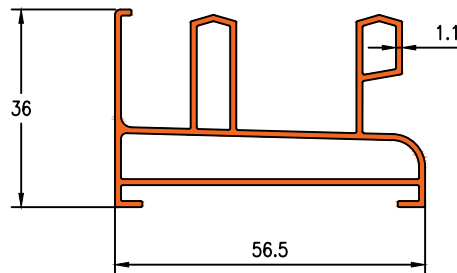

Die No. 16528

1.095KG/M

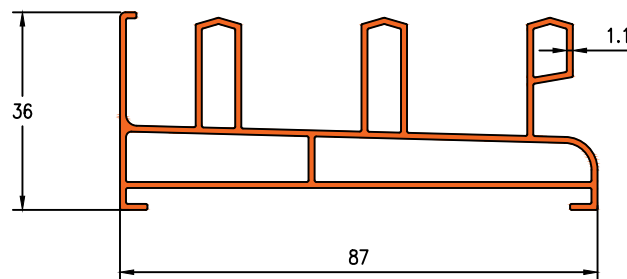

Die No. 16529

1.554KG/M

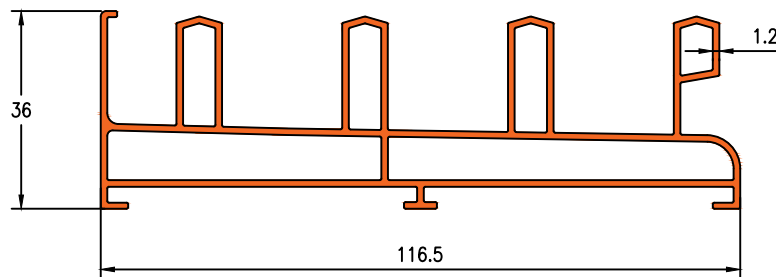

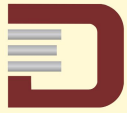

Die No. 16184

0.542 KG/M

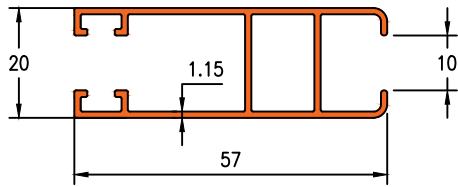

CLIP: 16182

Die No. 22029

0.583 KG/M

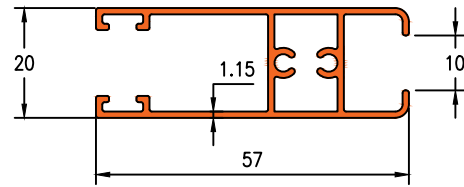

Die No. 16500

0.561 KG/M

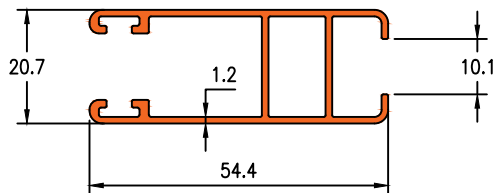

Die No. 22028

0.612 KG/M

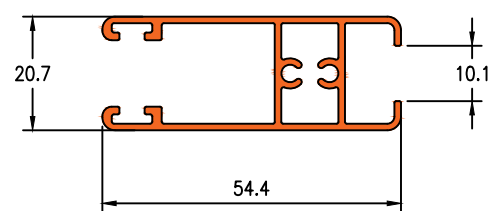

Die No. 19552

0.563 KG/M

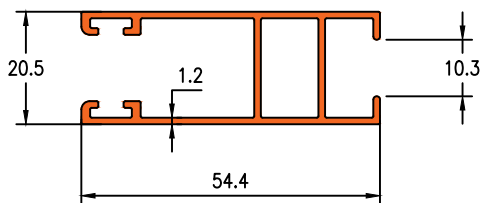

CLIP: 16182

Die No. 21162

0.433 KG/M

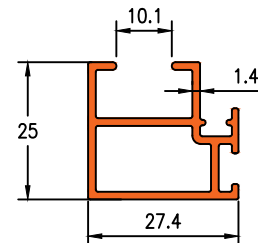

Die No. 20032

0.429 KG/M

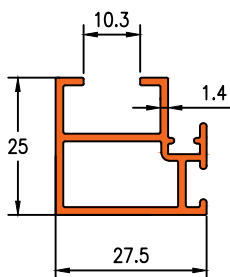

Die No. 16182

0.238 KG/M

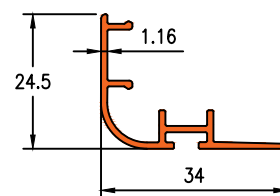



Die No. 7115

0.924KG/M

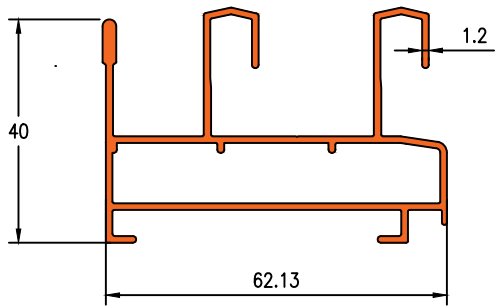

Die No. 7116

1.301KG/M

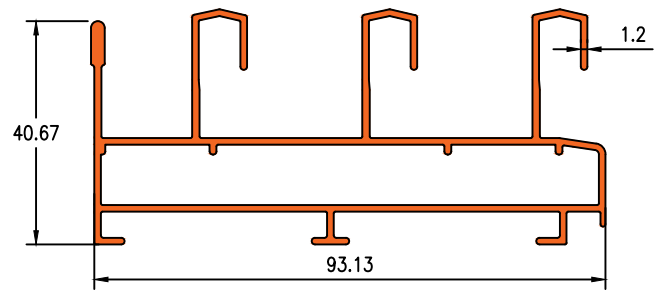

Die No. 7114

0.421KG/M

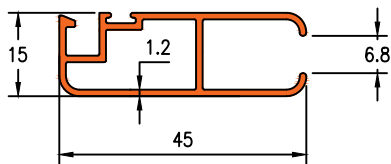

Die No. 7112

0.579KG/M

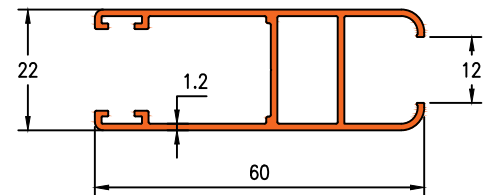

Die No. 7113

0.262KG/M

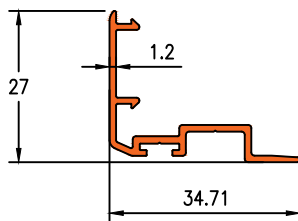



Die No. 16119

0.962KG/M

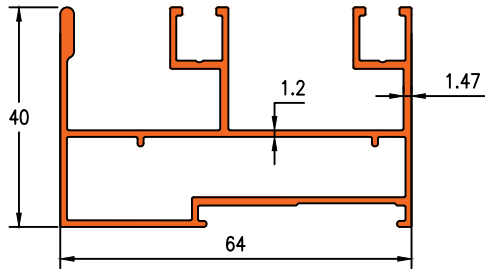

Die No. 16118

1.357KG/M

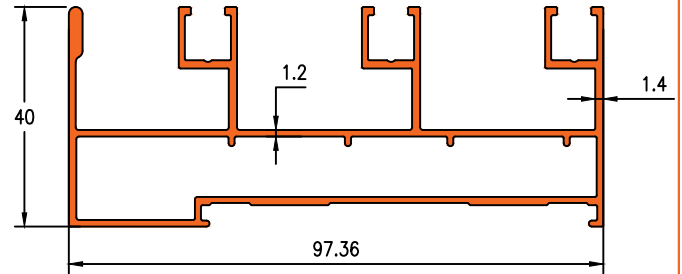

Die No. 16120

0.583KG/M

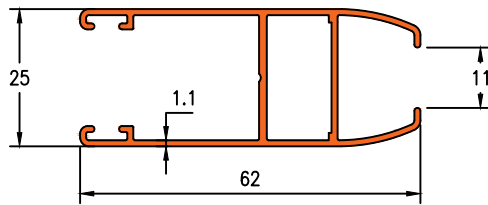

Die No. 16121

0.399 KG/M

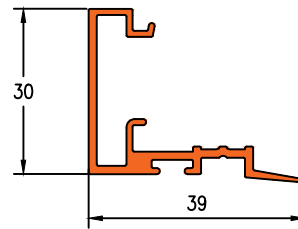

CLIP : 16121

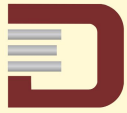

Die No. 19454

0.722KG/M

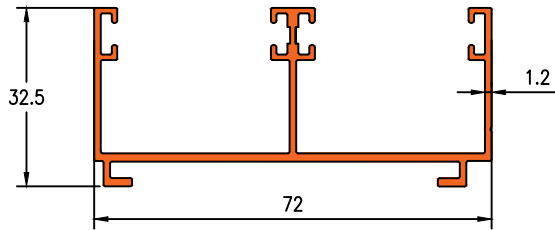

Die No. 19391

0.981KG/M

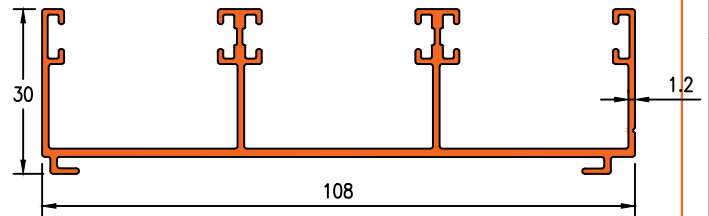

Die No. 19453

1.343KG/M

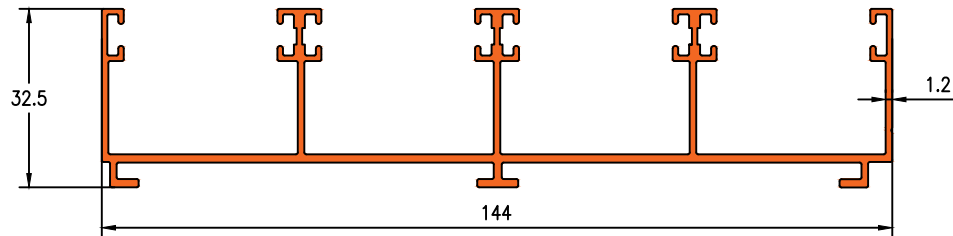

Die No. 19835

0.512KG/M

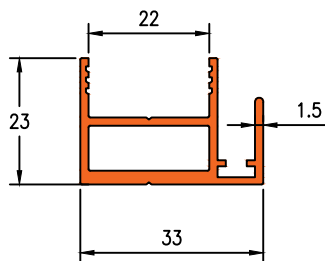

Die No. 19389

0.502KG/M

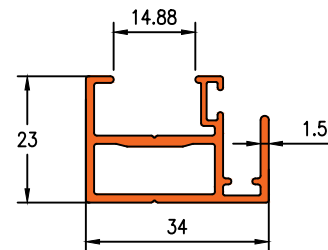

Die No. 19388

0.729KG/M

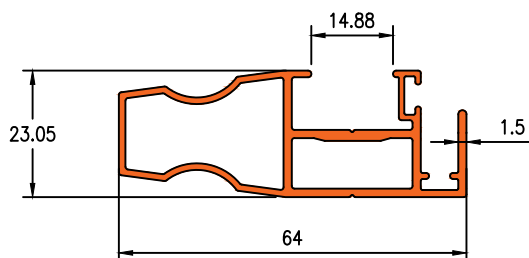

Die No. 19387

0.575KG/M

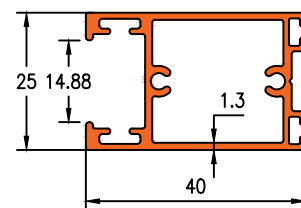

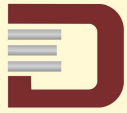

Die No. 19836

0.578KG/M

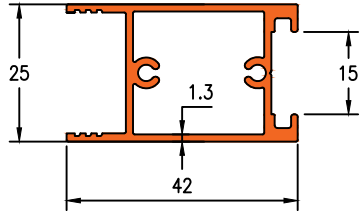

Die No. 19386

0.567KG/M

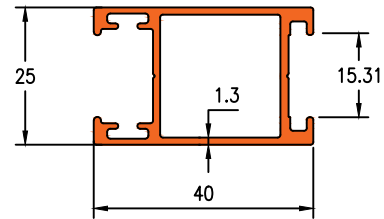

Die No. 19390

0.286KG/M

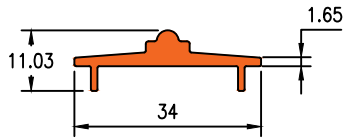



Die No.19920

0.624KG/M

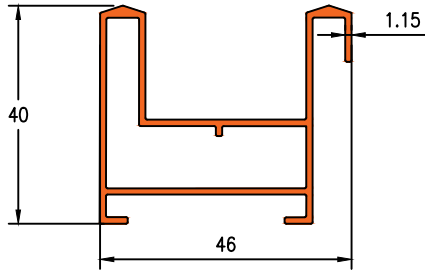

Die No.19917

0.965KG/M

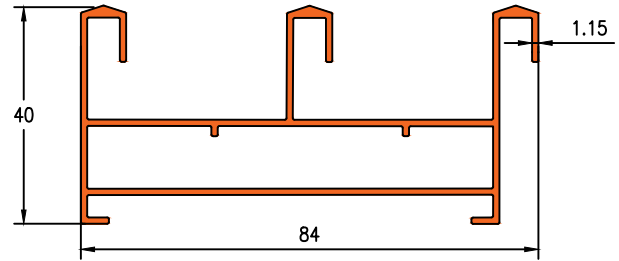

Die No. 16423

0.566KG/M

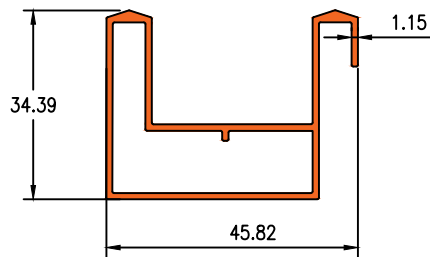

Die No.19656

0.908KG/M

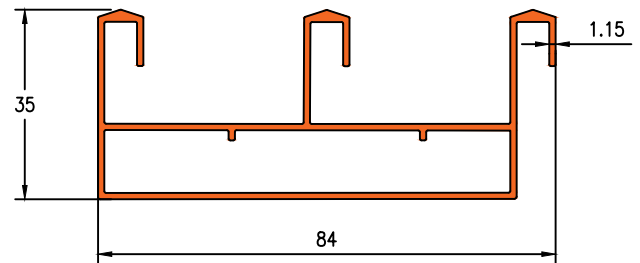

Die No.19677

0.814KG/M

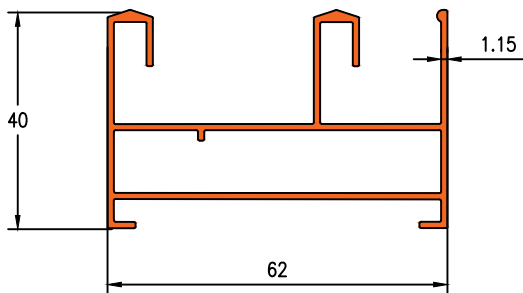

Die No.19678

1.176KG/M

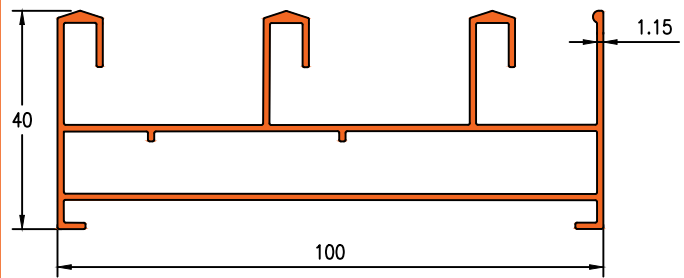

Die No. 16422

0.997KG/M

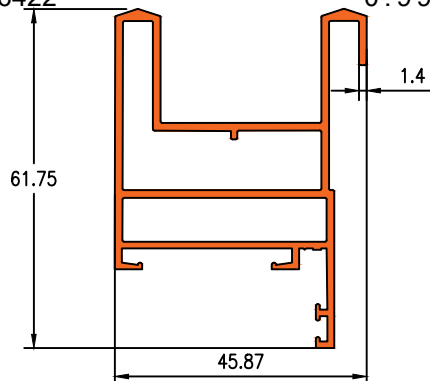

Die No.19650

1.324KG/M

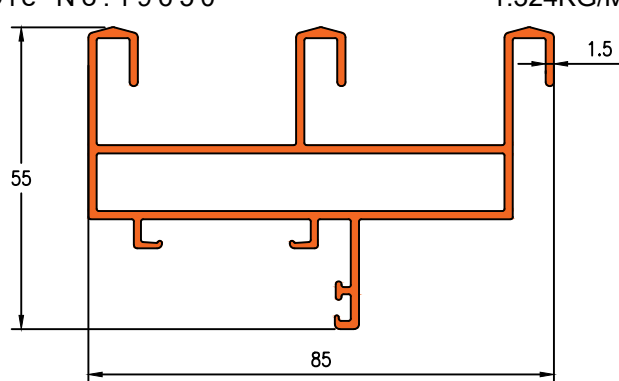

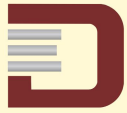

Die No.19951

1.064KG/M

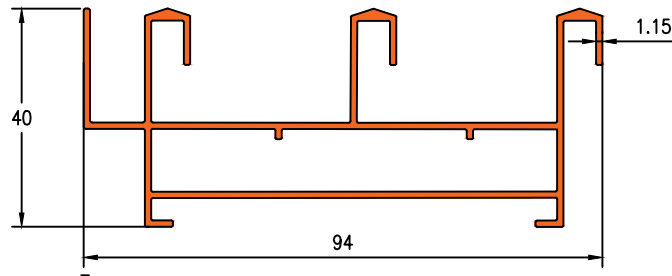

Die No.21251

1.609KG/M

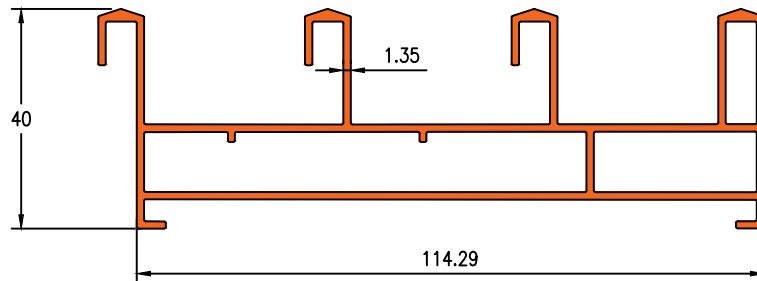

Die No. 16424

0.454KG/M

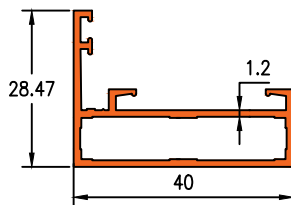

Die No.19916

0.647KG/M

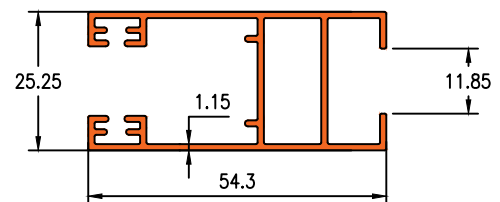

Die No.19913

0.402KG/M

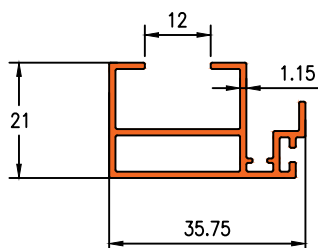

Die No.19475

0.661KG/M

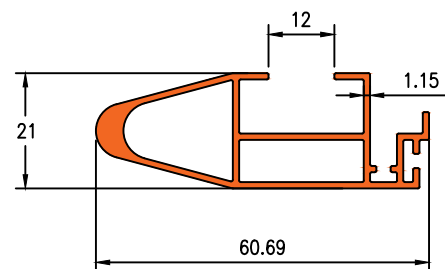



Die No.19950

0.601KG/M

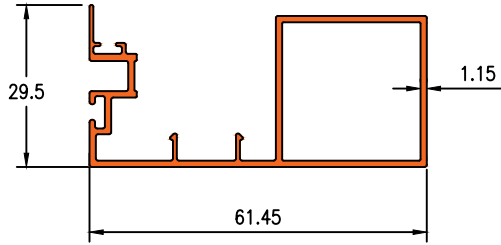

Die No.19662

0.251KG/M

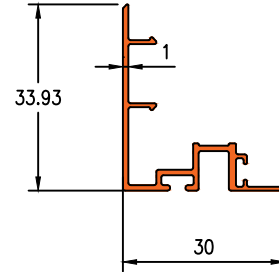



Die No. S7011

0.927KG/M

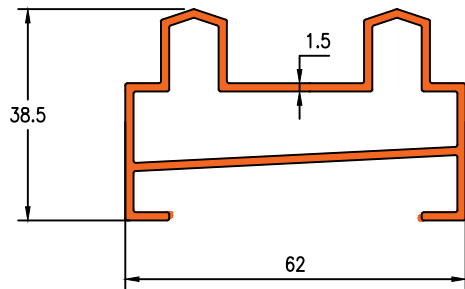

Die No. S7013

1.224KG/M

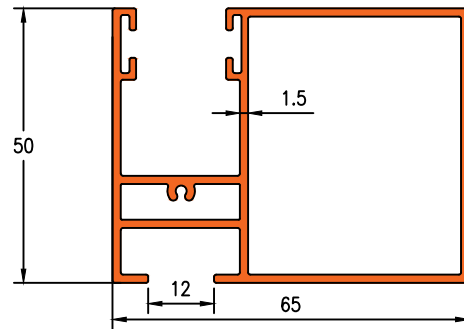

Die No. S7014

0.613KG/M

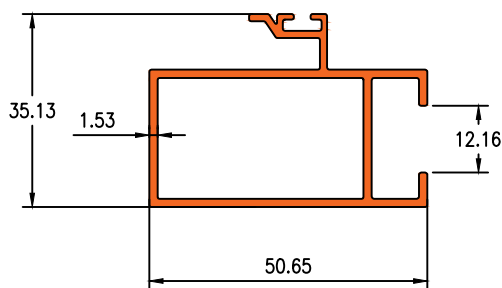

Die No. S7012

1.394 KG/M

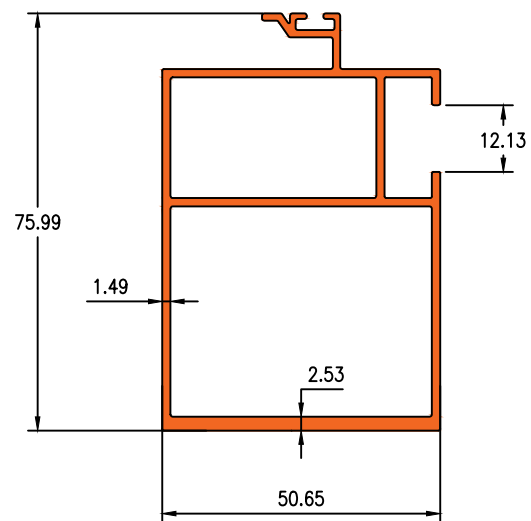

Die No. S7015

0.744KG/M

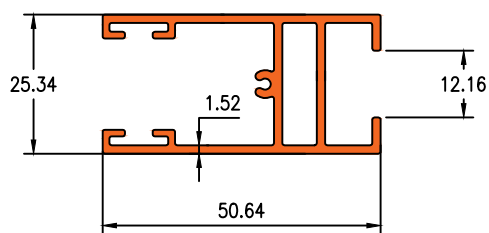



Die No. 19518

2.235KG/M

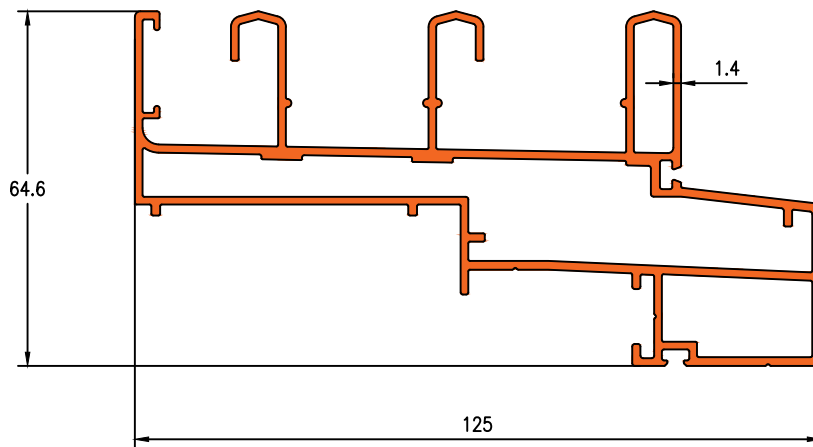

Die No. 19519

1.792KG/M

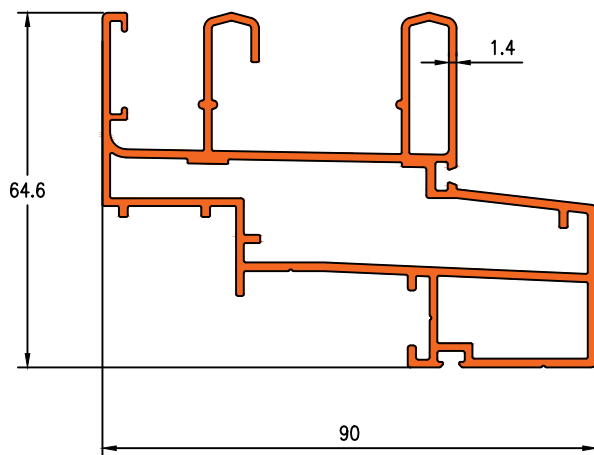

Die No. 19520

0.971KG/M

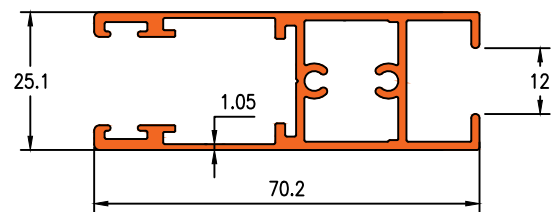

Die No. 19913

0.402KG/M

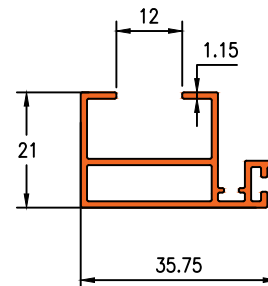



Die No. 7134

1.464KG/M

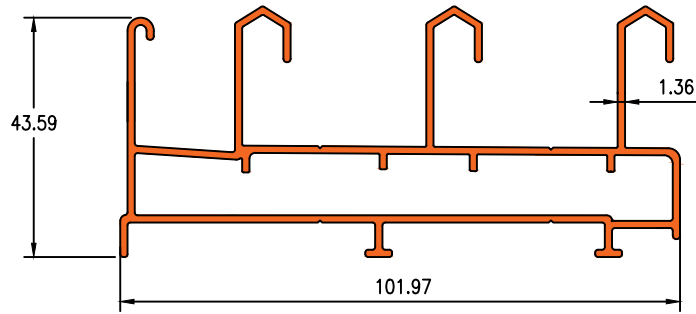

Die No. 7133

0.729KG/M

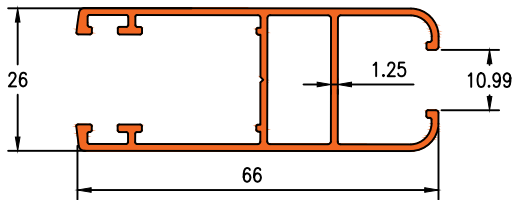

CLIP : 16141



Die No. 21074

1.029KG/M

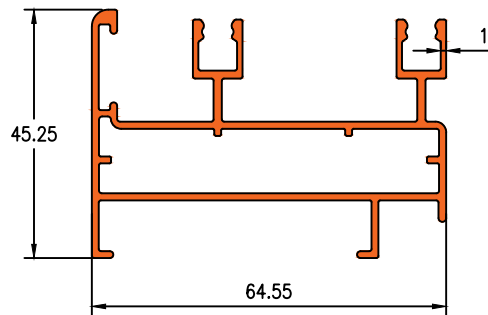

Die No. 21059

1.409KG/M

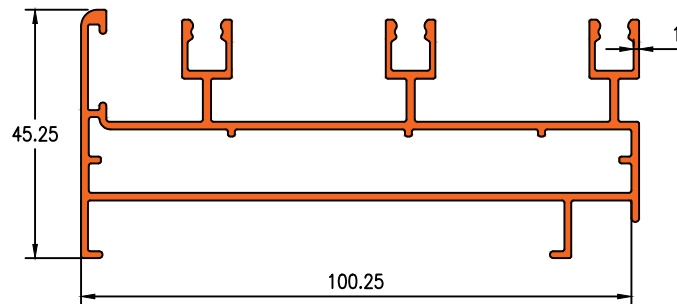

Die No. 23091

2.059KG/M

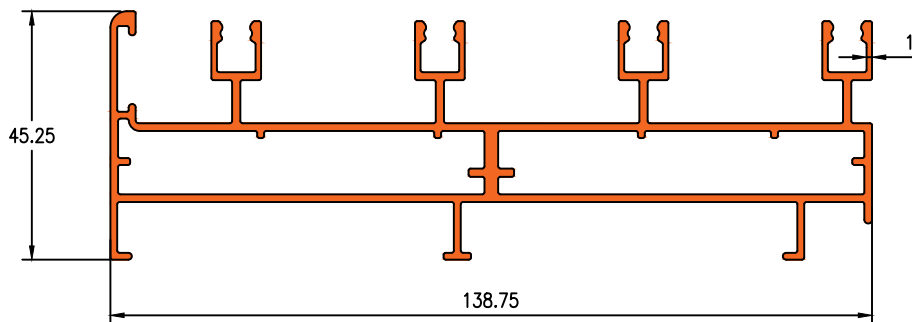

Die No. 21094

0.057 KG/M

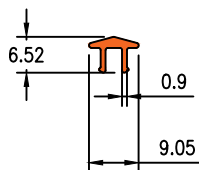



Die No. 21113

0.996KG/M

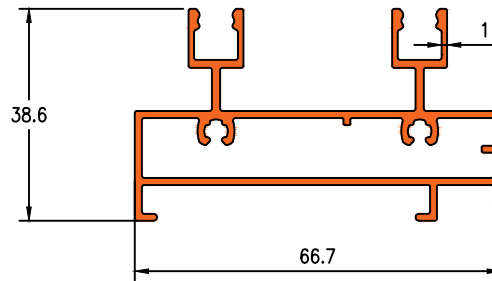

Die No. 21114

1.394KG/M

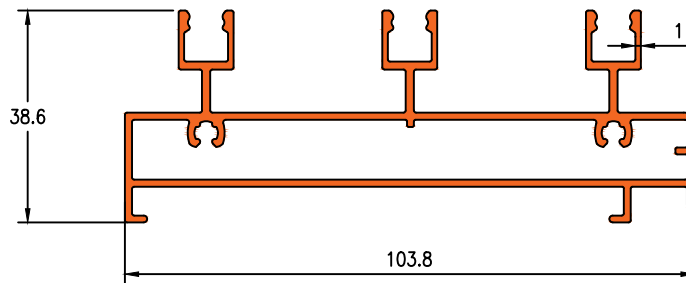

Die No. 21115

0.519KG/M

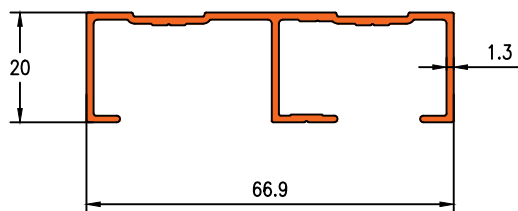

Die No. 21116

0.651KG/M

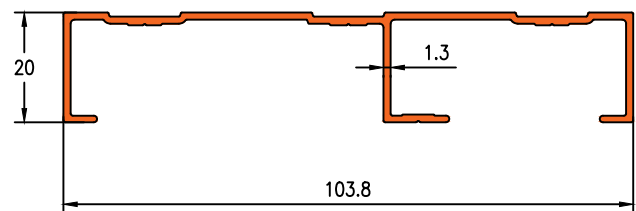

Die No. 21119

0.685KG/M

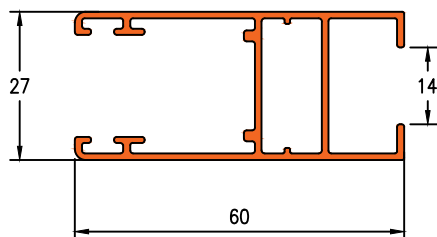

Die No. 21117

0.145KG/M

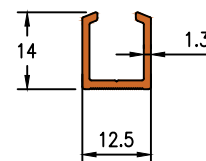



Die No. 21118

0.512KG/M

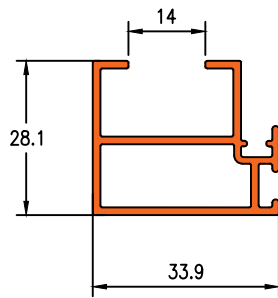

Die No. 21183

0.817KG/M

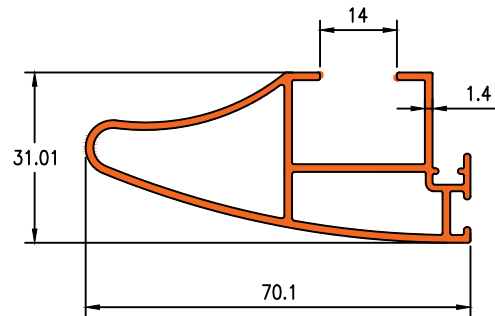

Die No. 16694

1.037KG/M

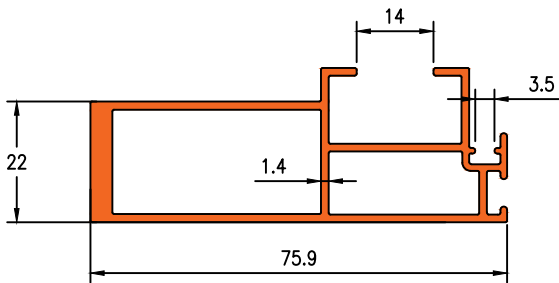



Die No. 1343

0.970KG/M

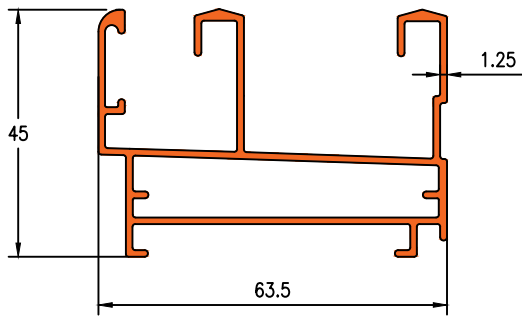

Die No. 21041

0.789KG/M

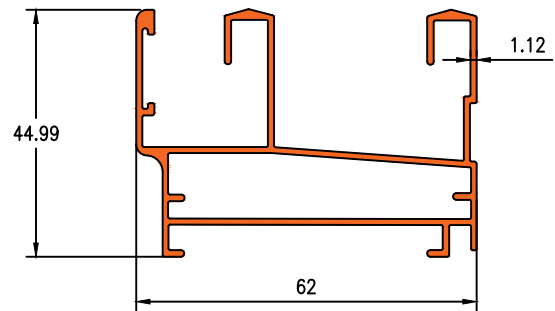

Die No. 1332

1.444KG/M

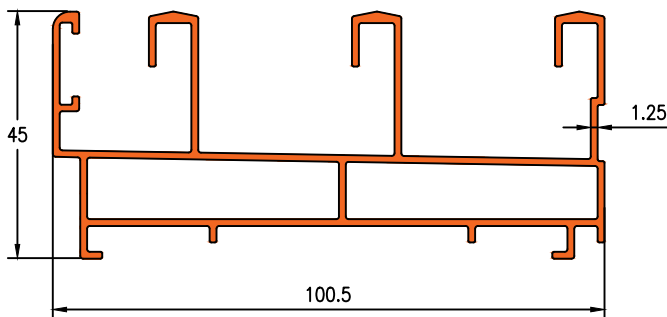

Die No. 21042

1.303KG/M

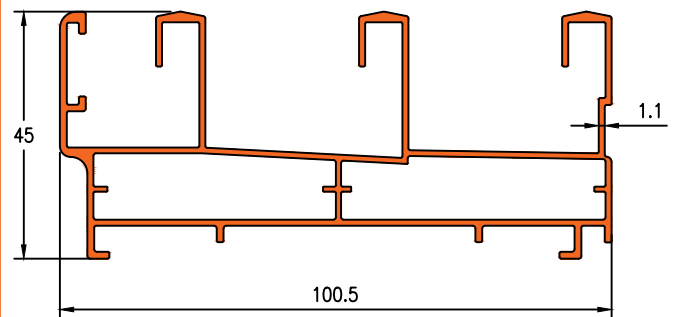

Die No. 28193

1.835KG/M

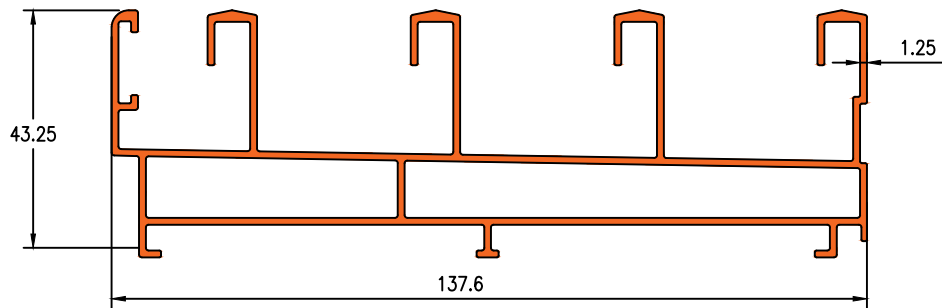

Die No. 1333

0.690KG/M

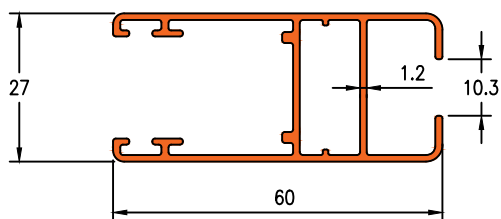

CLIP : 1331

Die No. 16180

0.675KG/M

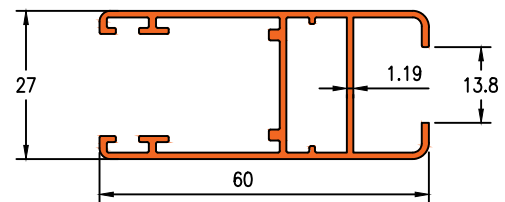

CLIP : 1331



Die No. 19735

0.644KG/M

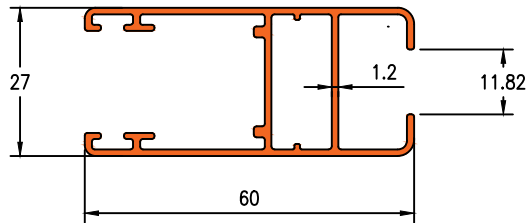

Die No. 1331

0.322KG/M

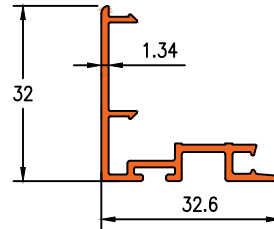

Die No. 20028

0.549KG/M

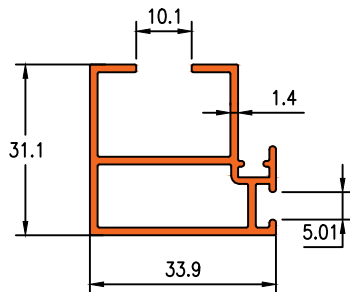

Die No. 20029

0.499KG/M

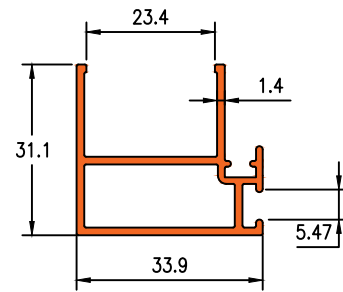

Die No. 20065

1.204KG/M

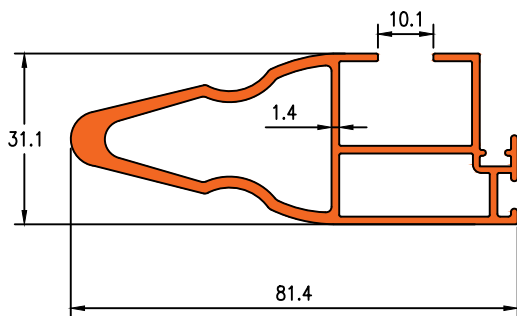

Die No.21096

1.154 KG/M

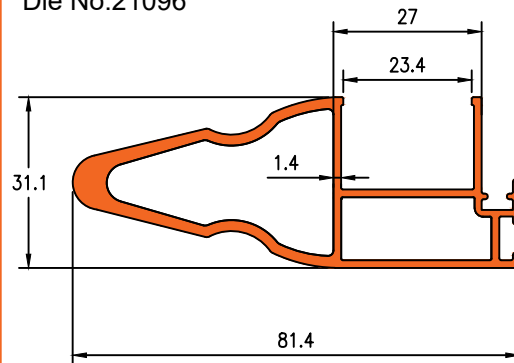

Die No. 19376

0.680KG/M

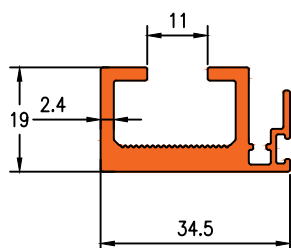

Die No. 19332

1.394KG/M

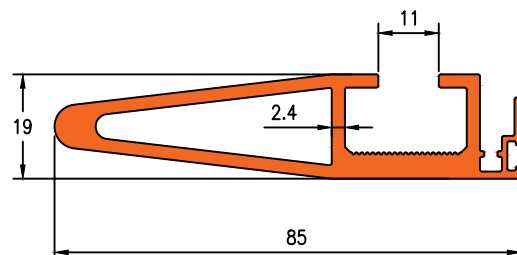



Die No. 2701

0.719KG/M

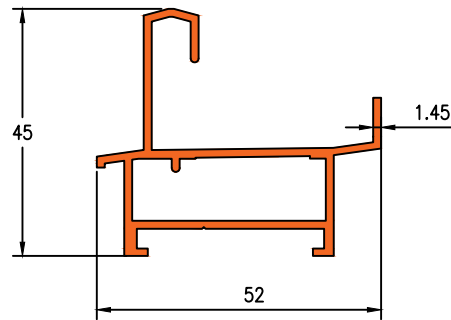

Die No. 2702

0.871KG/M

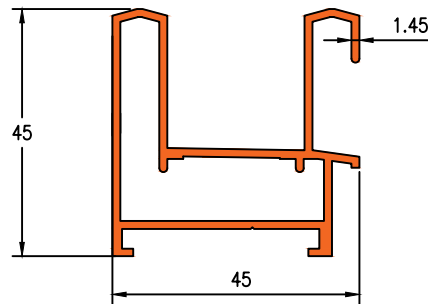

Die No. 2703

1.398KG/M

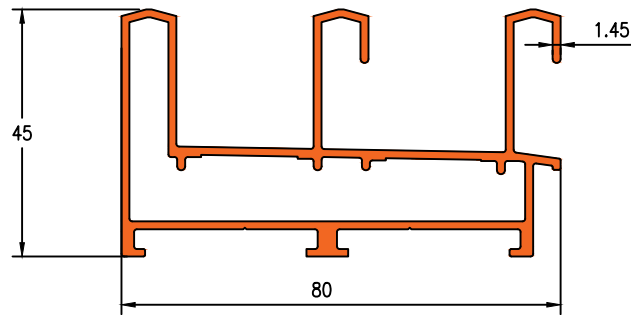

Die No. 2704

1.905KG/M

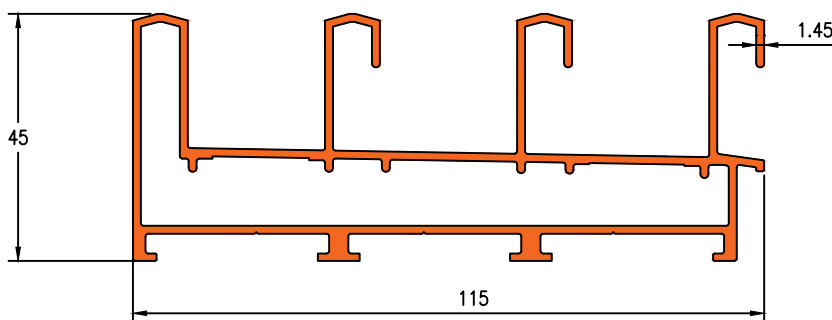



Die No. 2708

0.862KG/M

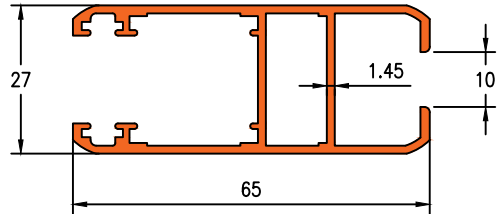

CLIP :2709 & 16141

Die No. 2707

0.890KG/M

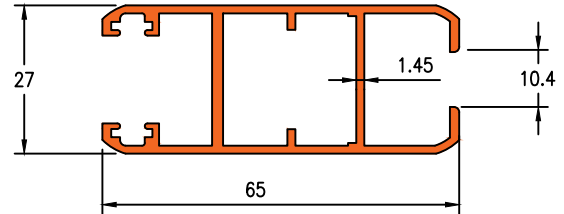

CLIP :2709 & 16141

Die No. 2705

0.810 KG/M

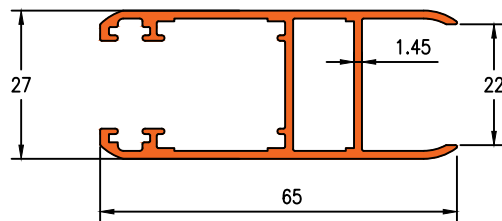

CLIP :2709 & 16141

Die No. 2706

0.838KG/M

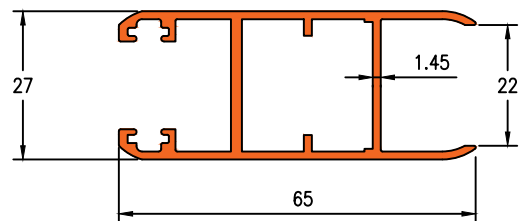

CLIP :2709 & 16141

Die No. 2709

0.273KG/M

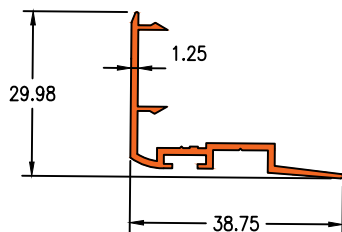

Die No. 2710

0.262KG/M

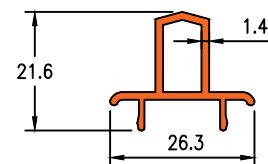



Die No. 19371

1.535KG/M

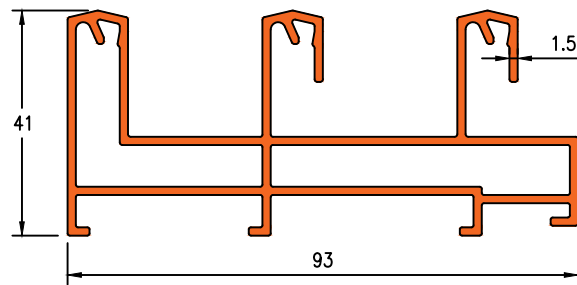

Die No. 19372

2.167KG/M

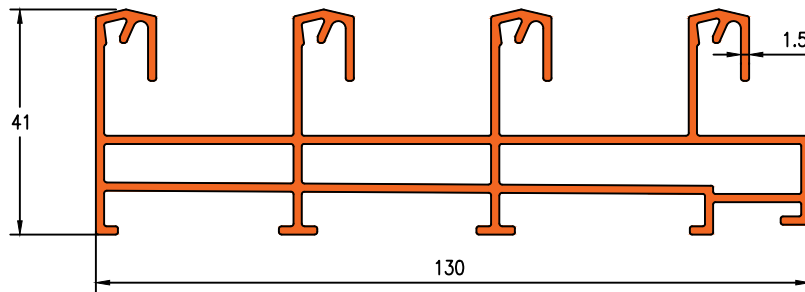

Die No. 21044

0.701KG/M
0.750KG/M

Die No. 19370

0.797KG/M

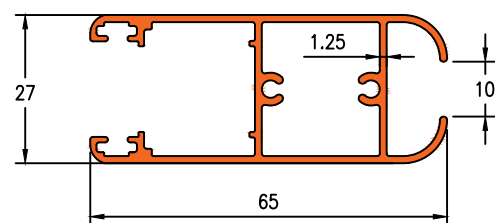
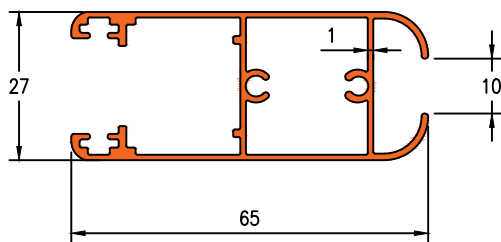

Die No. 21043

0.308KG/M

Die No. 21103

0.302KG/M

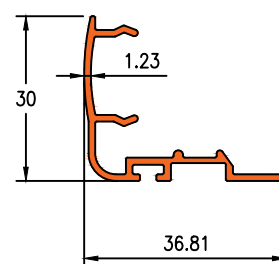
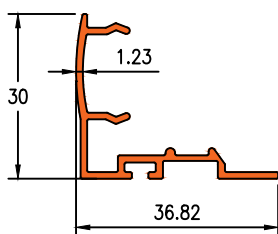



Die No. 1211

0.693KG/M

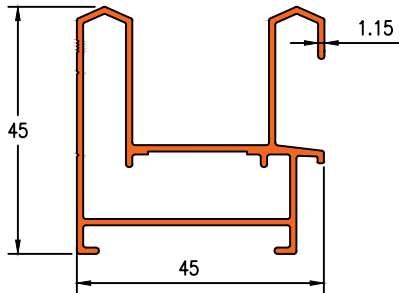

Die No. 1210

1.081KG/M

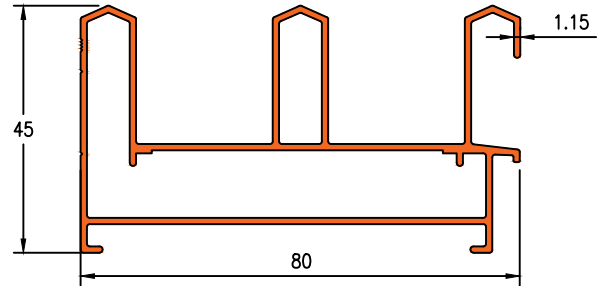

Die No. 1212

0.755KG/M
0.855 KG/M

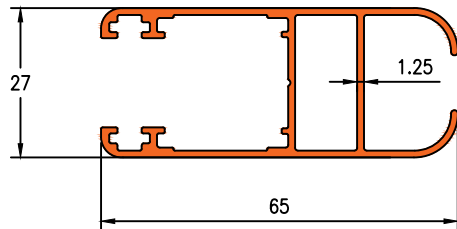

CLIP : 1213

Die No. 1213

0.260KG/M

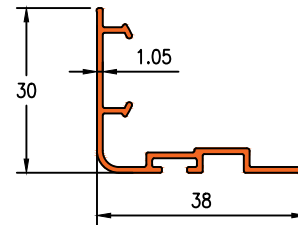

Die No. 16177

1.262KG/M

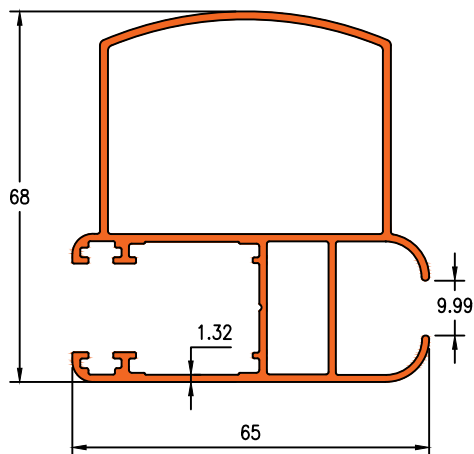

CLIP : 1213

Die No. 28197

0.681KG/M

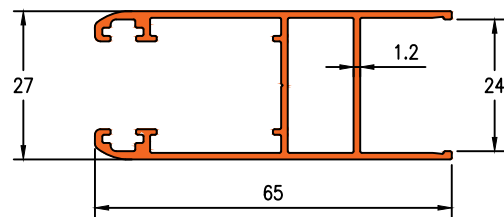

Die No. 28192

0.272KG/M

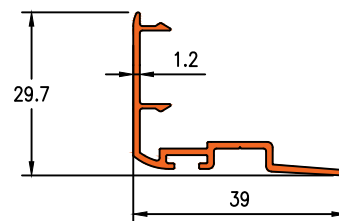



Die No.21214

1.045KG/M

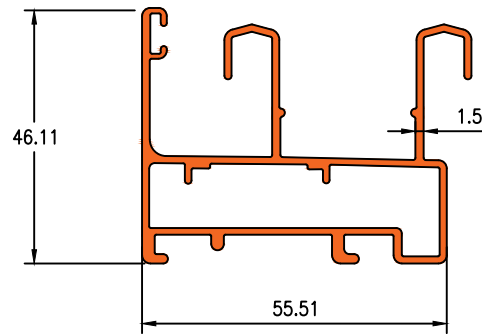

Die No.21213

1.473KG/M

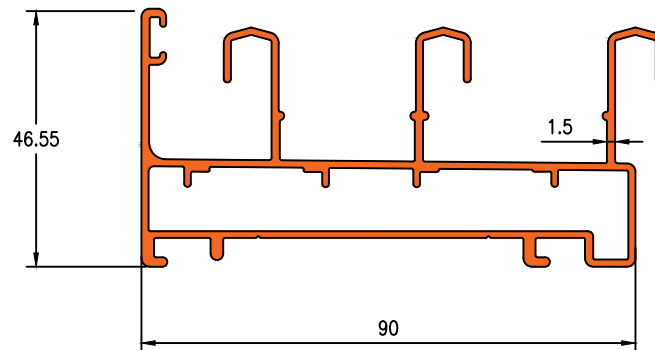

Die No.21215

1.775KG/M

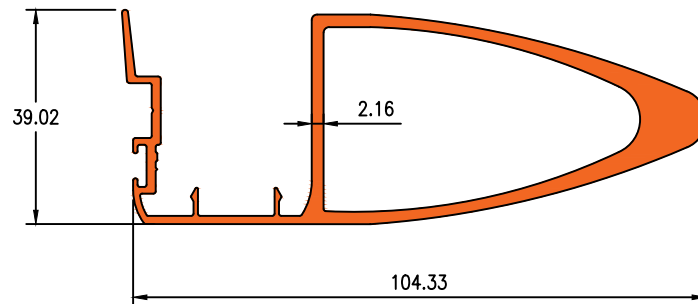

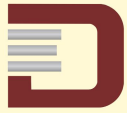

Die No. 16197

1.108KG/M

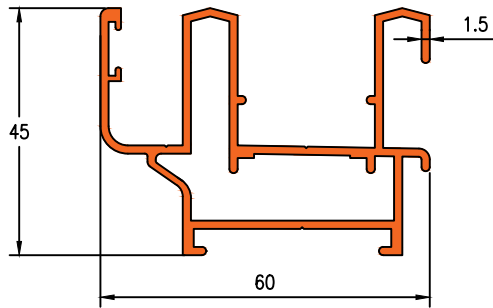

Die No. 16195

1.586KG/M

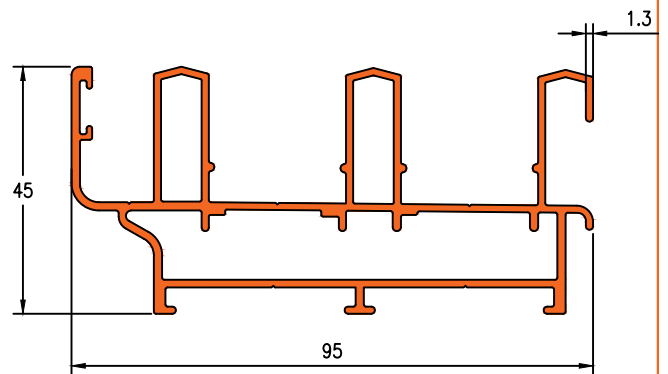

Die No. 19474

1.107KG/M

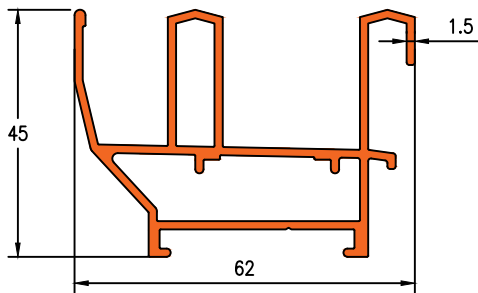

Die No. 16199

0.247KG/M

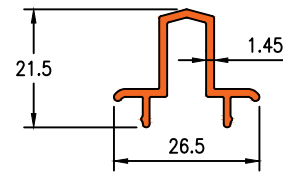

Die No. 16200

0.860KG/M

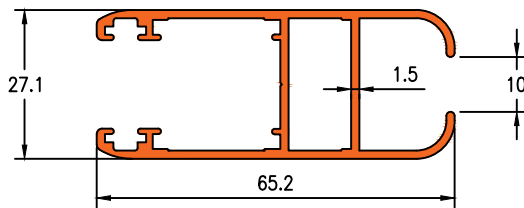

Die No. 16198

0.829KG/M

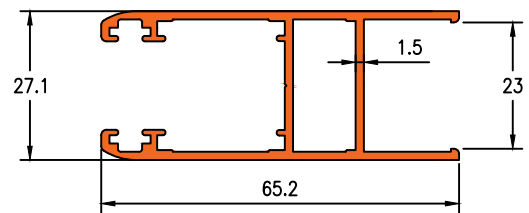

Die No. 16209

1.180KG/M

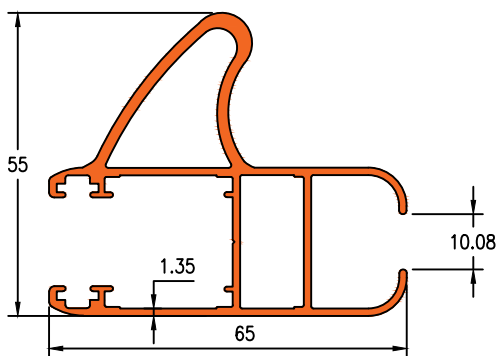

Die No. 16196

0.272KG/M

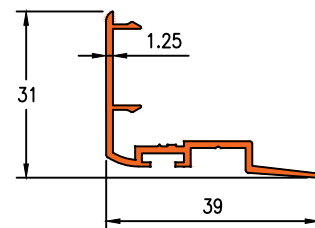



Die No. 19625

1.865KG/M

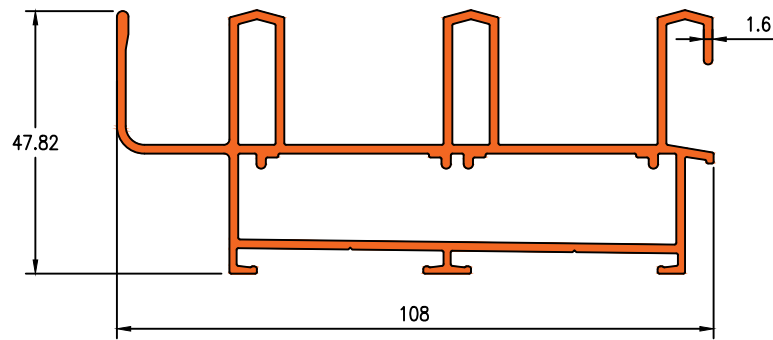

Die No. 19626

1.185KG/M

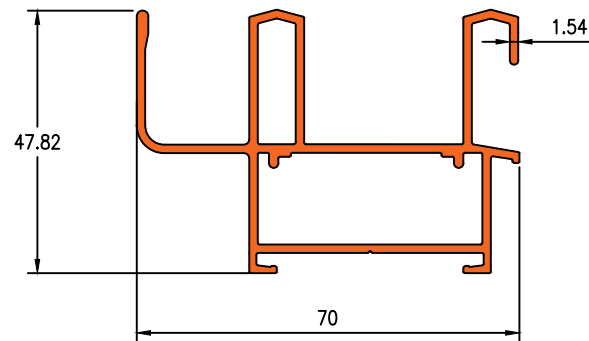

Die No. 19620

0.779KG/M

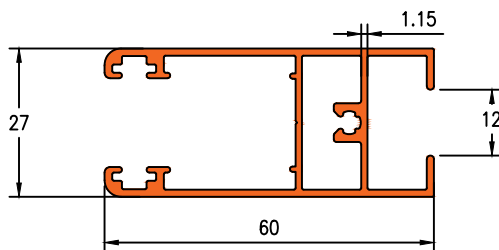

Die No. 19623

1.082KG/M

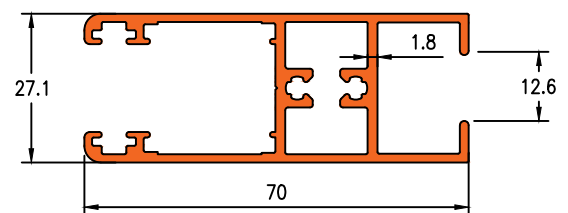



Die No. 16105

1.856KG/M

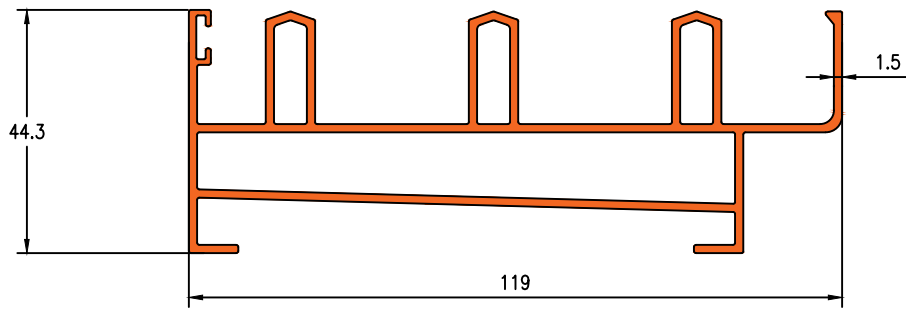

Die No. 16106

0.970KG/M

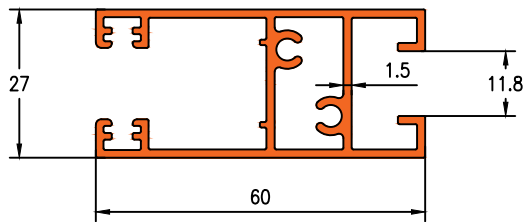

Die No. 16108

0.612KG/M

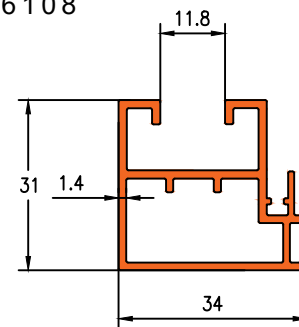

Die No. 16107

1.347KG/M

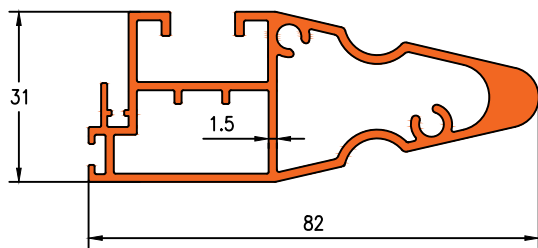

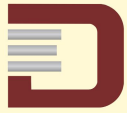

Die No. 16138

0.629KG/M

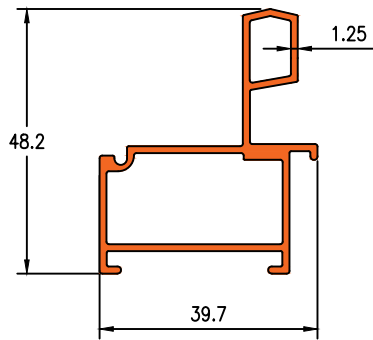

Die No. 16137

1.112KG/M

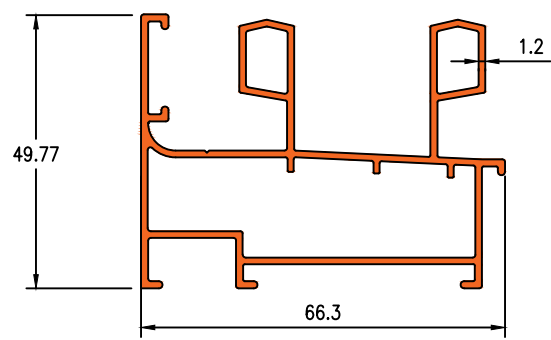

Die No. 16136

1.584 KG/M

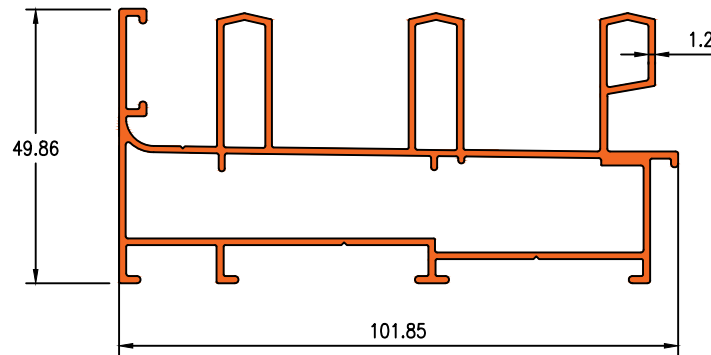

Die No. 16135

2.225KG/M

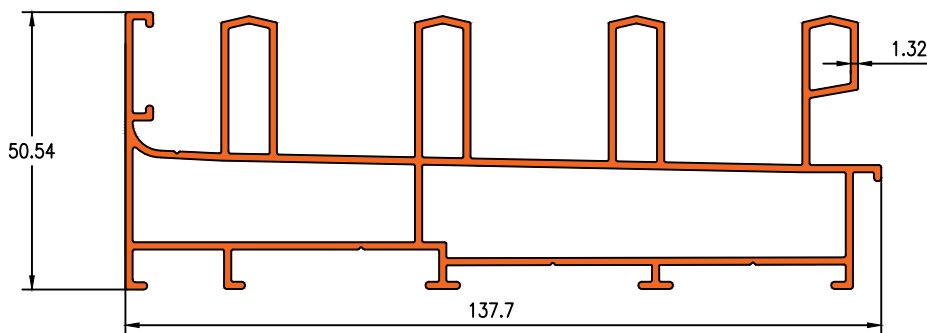

Die No. 19537

3.091KG/M

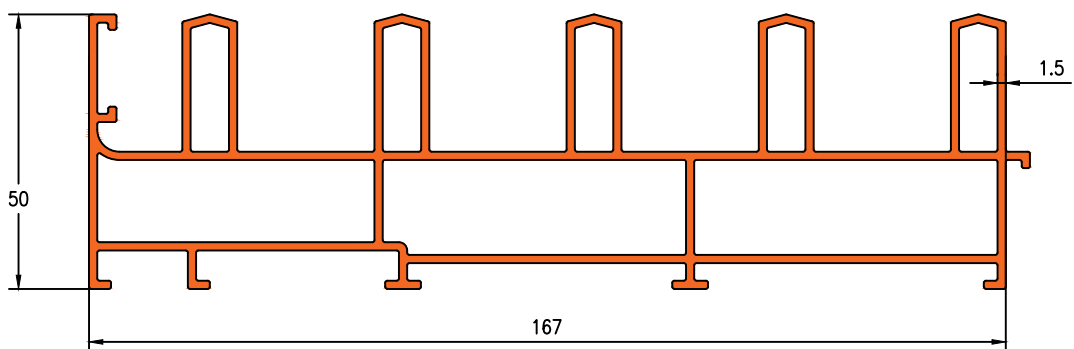

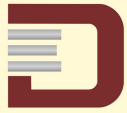

Die No. 16140

0.744KG/M

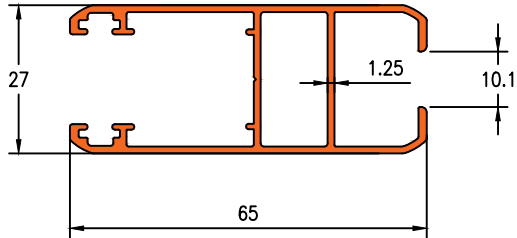

Die No. 16139

0.723KG/M

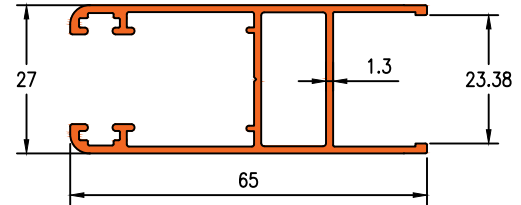

Die No. 19722

0.699KG/M

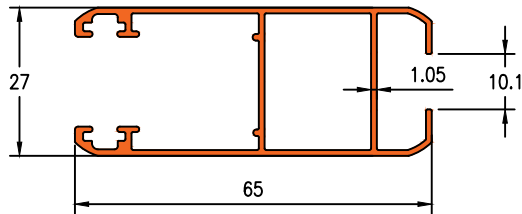

Die No. 21019

0.794KG/M

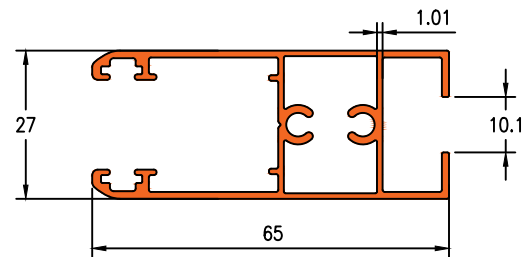

Die No. 20028

0.549KG/M

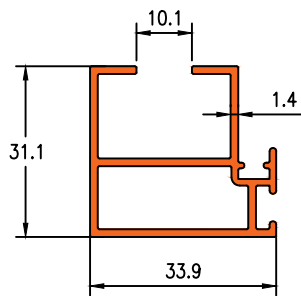

Die No. 20029

0.499KG/M

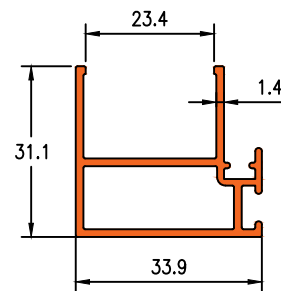

Die No. 20065

1.204KG/M

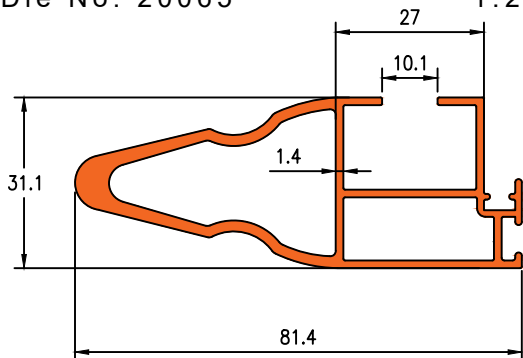

Die No. 21096

1.154 KG/M

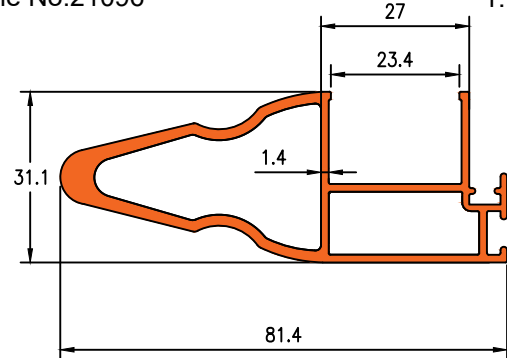



Die No. 16141

0.273KG/M

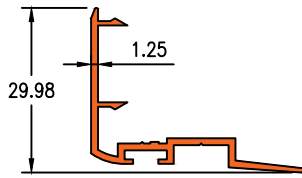

Die No. 19469

0.177KG/M

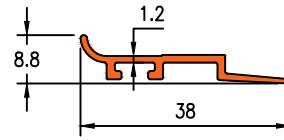

Die No. 19478

0.748KG/M

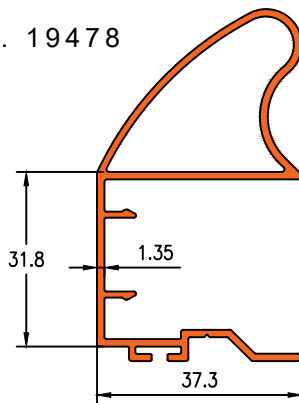

Die No. 20017

0.117KG/M

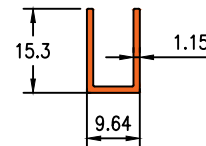

Die No. 21018

0.549KG/M

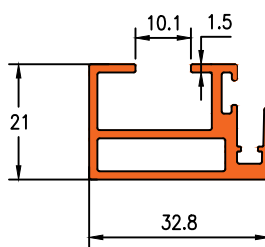

Die No. 23108

1.014KG/M

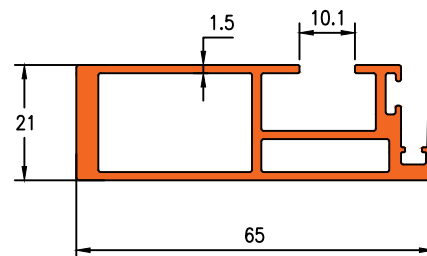

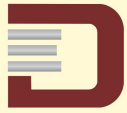

Die No. 5117

1.394KG/M

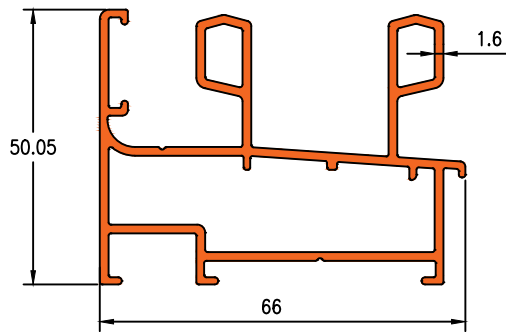

Die No. 16710

1.350KG/M

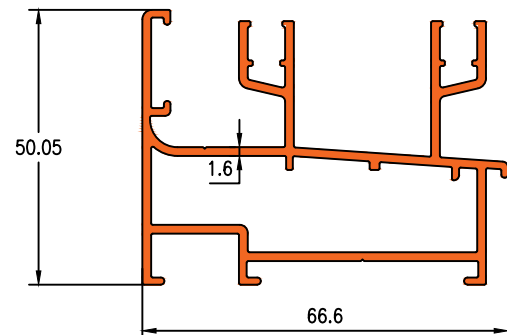

Die No. 5178

1.720KG/M

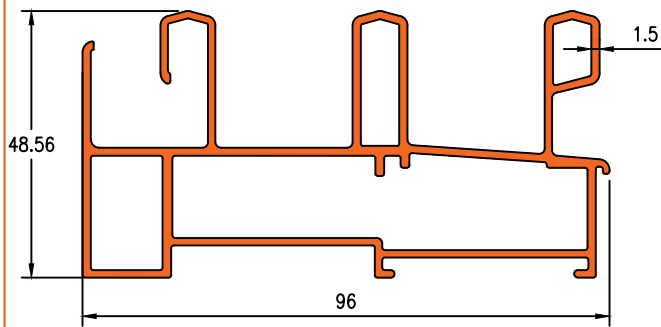

Die No. 5160

2.049KG/M

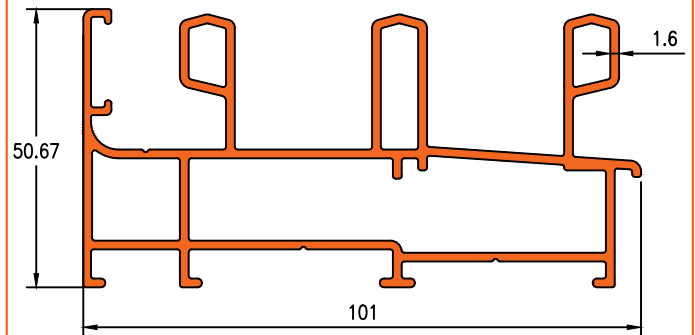

Die No. 5123

0.785KG/M

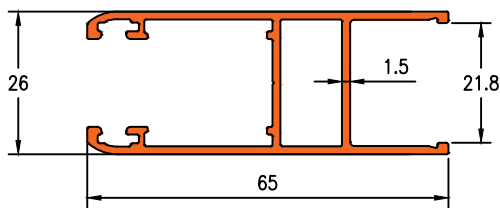

Die No. 5118

0.788KG/M

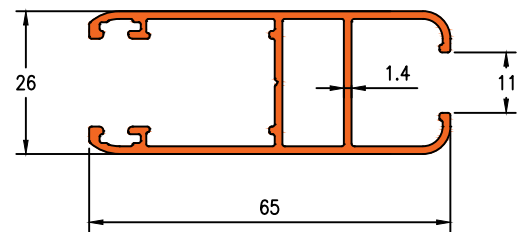

Die No. 5116

0.329KG/M

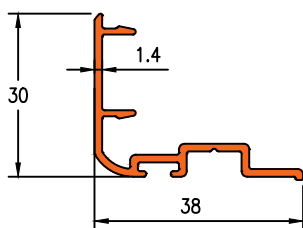

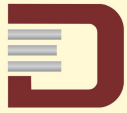

Die No. 21036

0.745KG/M

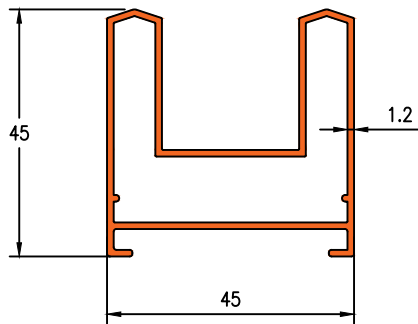

Die No. 21035

1.155KG/M

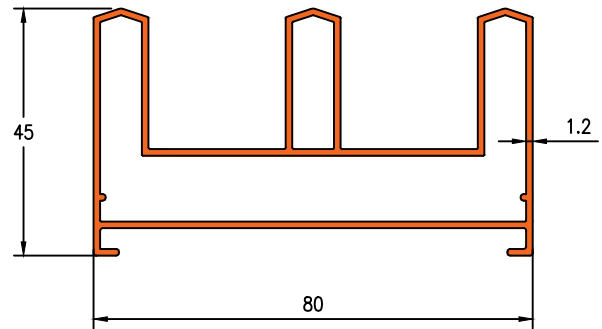

Die No. 21060

1.251KG/M

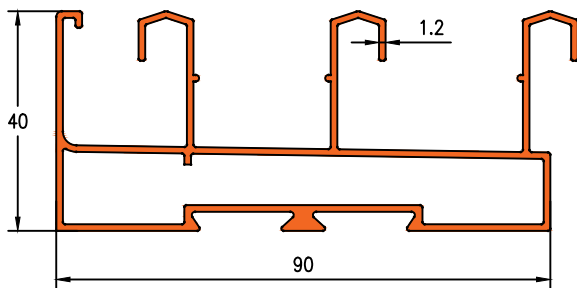

Die No. 21038

0.663KG/M

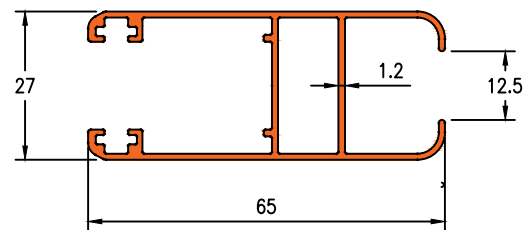

Die No. 16141

0.273KG/M

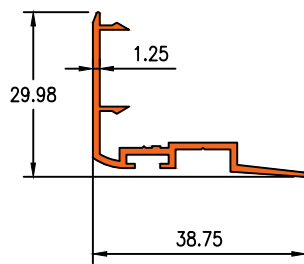

Die No. 21039

1.026KG/M

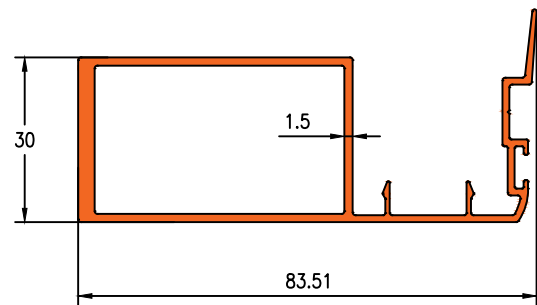



Die No. 19671

1.826KG/M

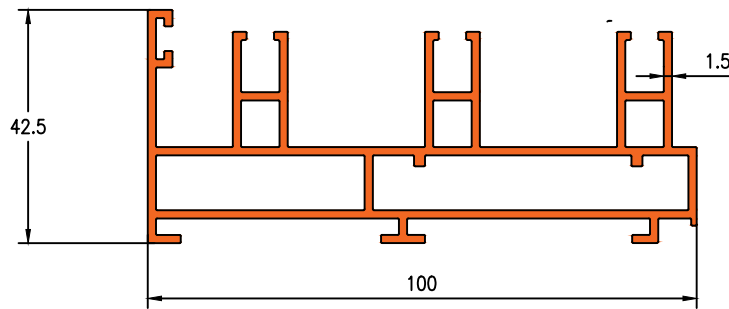

Die No. 16462

2.083KG/M

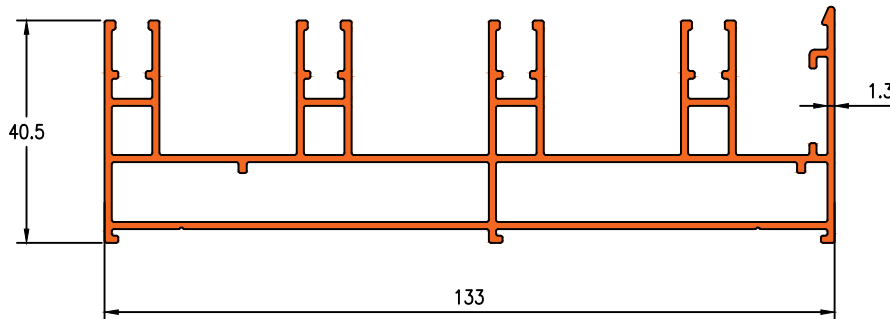

Die No. 19669

0.871KG/M

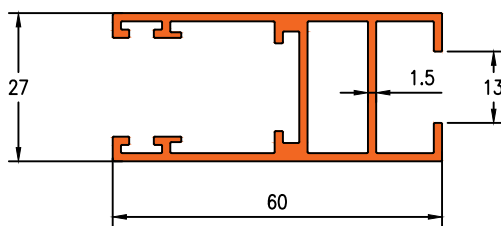

Die No. 19670

0.717KG/M

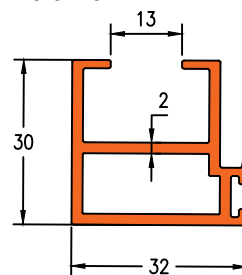

Die No. 19672
0.094KG/M

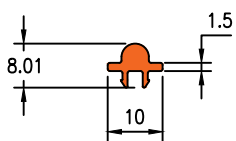

Die No. 19674
0.218KG/M

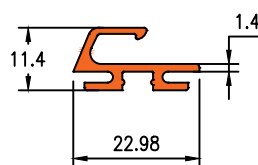

Die No. 19673

1.380KG/M

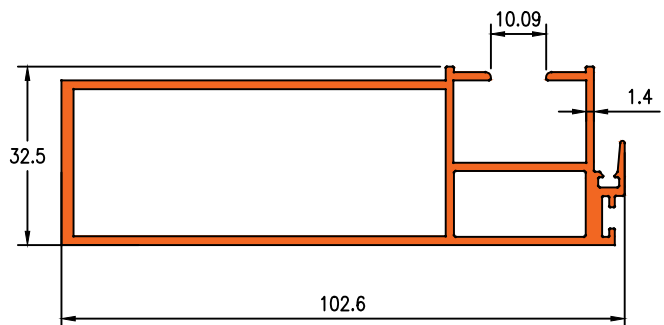

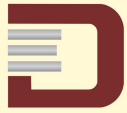

Enq No. 1556

1.109KG/M

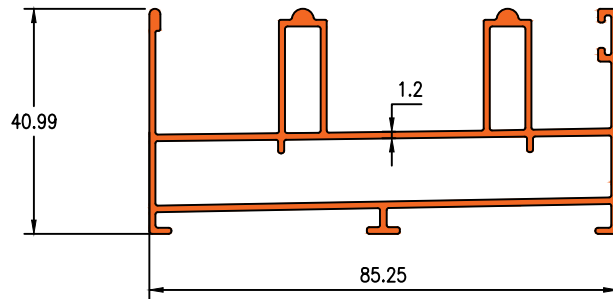

Enq No. 1550

1.470 KG/M

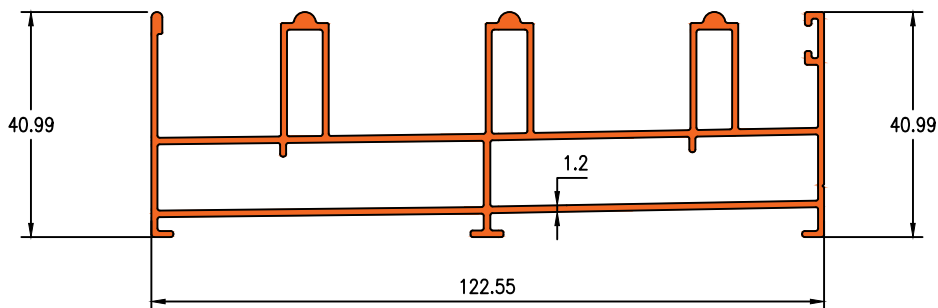

Enq No. 1551

0.774KG/M

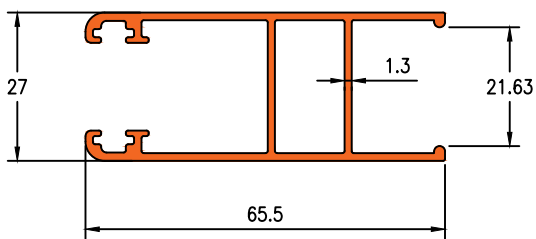

Enq No. 1553

0.490KG/M

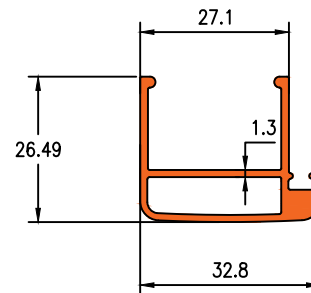

Enq No. 1554

0.809KG/M

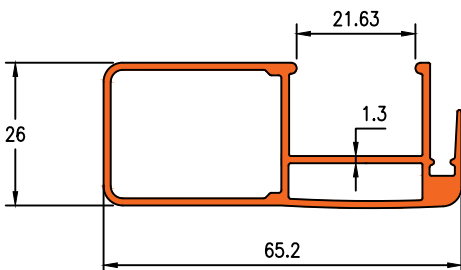

Enq No. 1552

0.721KG/M

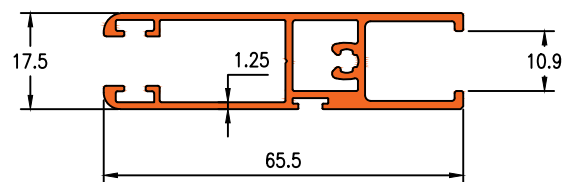



Enq No. 1555

0.193KG/M

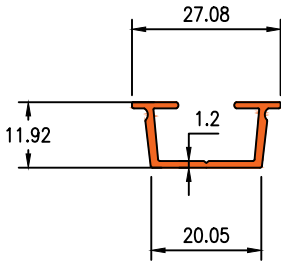



Enq No. 1562

1.314 KG/M

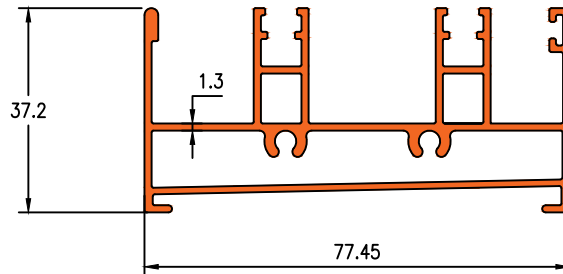

Enq No. 1563

1.725 KG/M

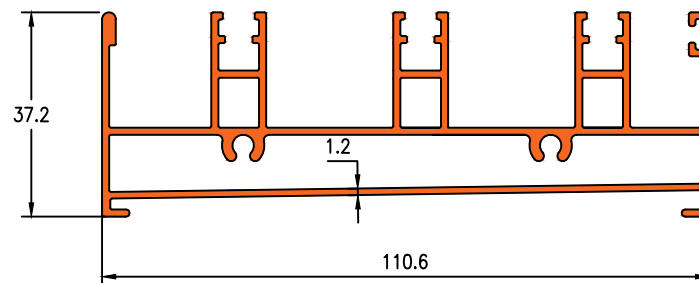

Enq No. 1558

0.815KG/M

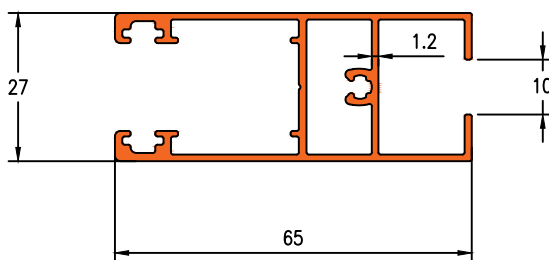

Enq No. 1559

0.590KG/M

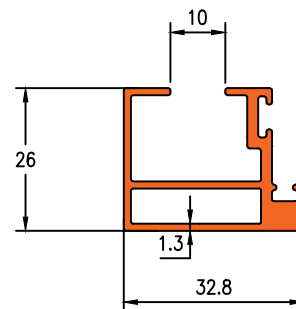

Enq No. 1560

0.992KG/M

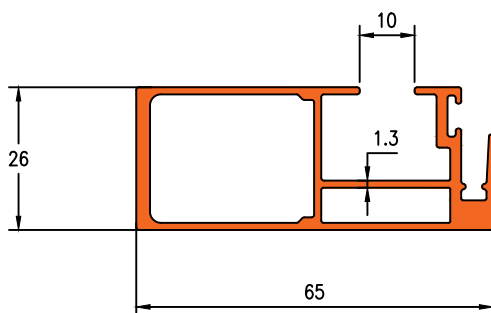

Enq No. 1561

0.639KG/M

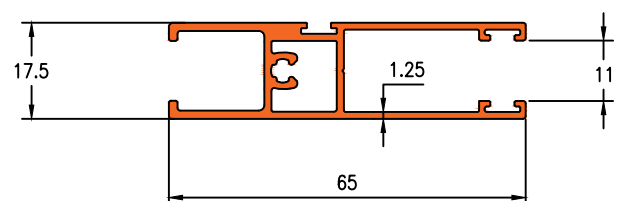



Enq No. 1959

1.242 KG/M

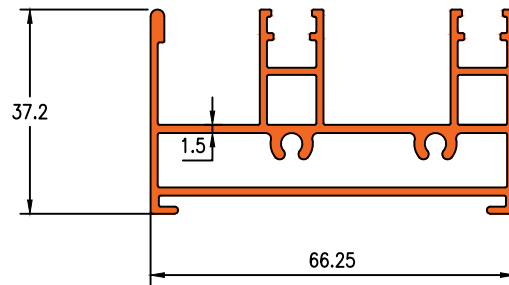

Enq No. 1960

1.717 KG/M

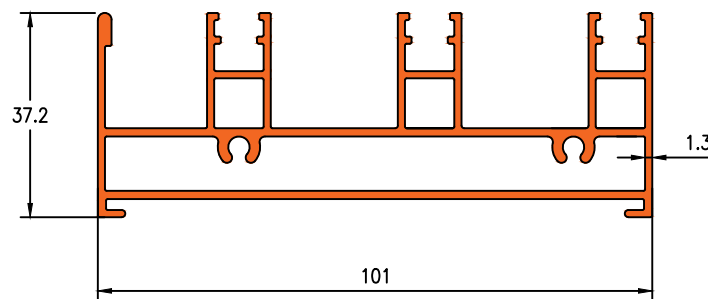

Enq No. 1961

0.877KG/M

Enq No. 1962

0.633KG/M

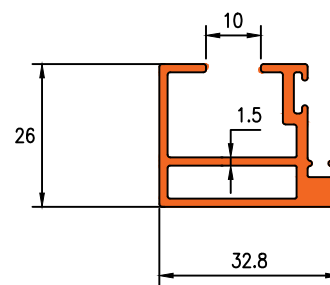
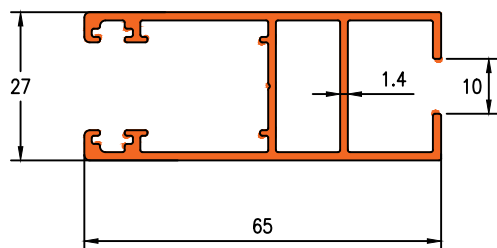

Enq No. 1963

1.161KG/M

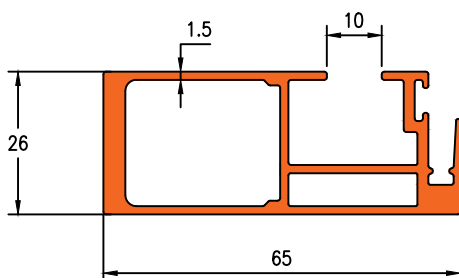



Die No.16698

1.079 KG/M

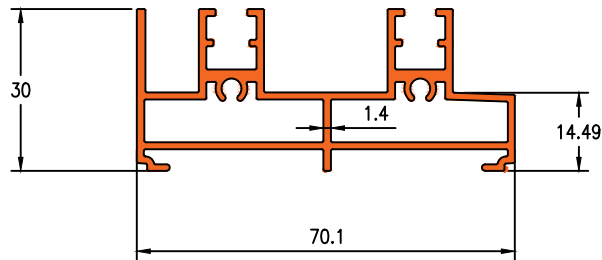

Die No.16699

0.780 KG/M

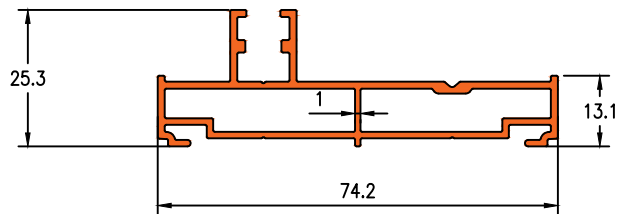

Die No.16701

1.552 KG/M

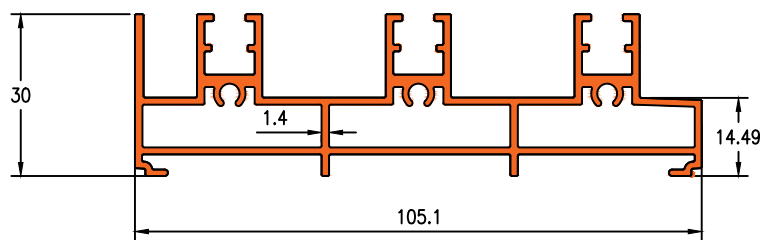

Die No.16702

1.054 KG/M

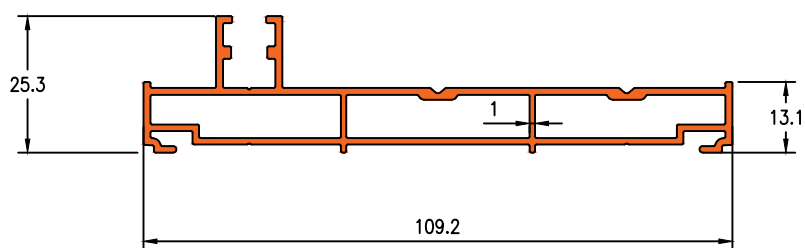



Die No. 21252

0.162 KG/M

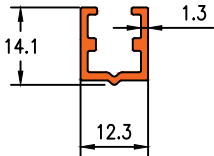

Die No. 16700

0.142 KG/M

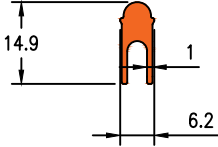



Die No.16452

0.974 KG/M

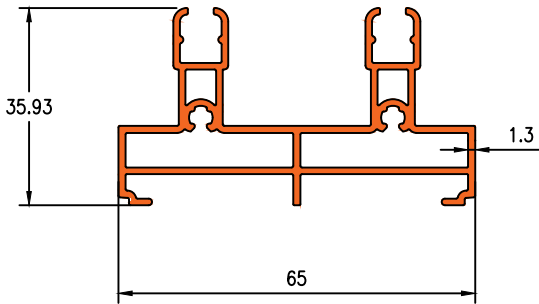

Die No.16450

1.381 KG/M

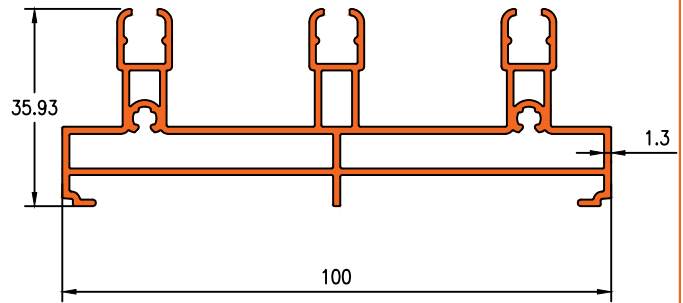

Die No.23103

1.865 KG/M

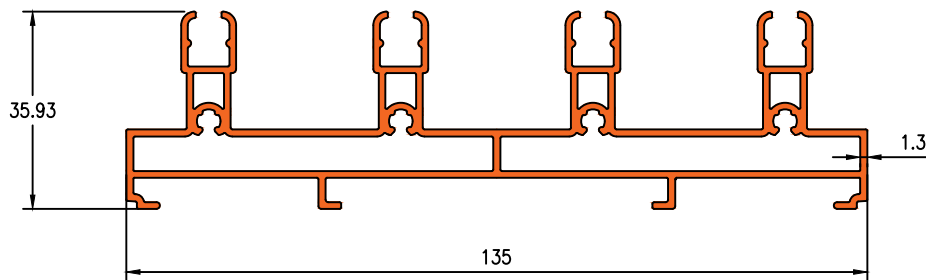

Die No.16451

0.786 KG/M

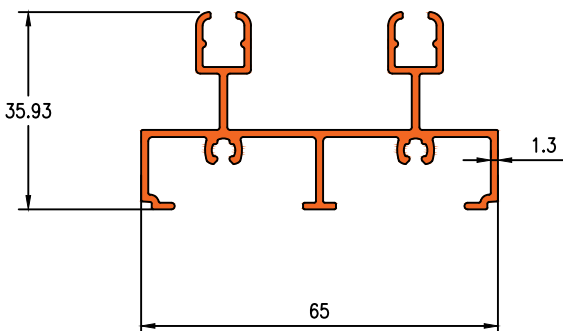

Die No.16449

1.052 KG/M

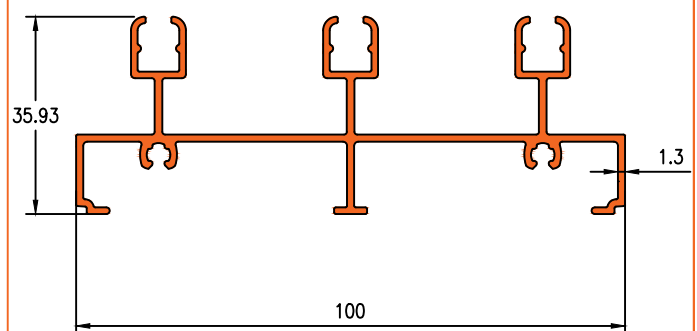



Die No.23104

1.457 KG/M

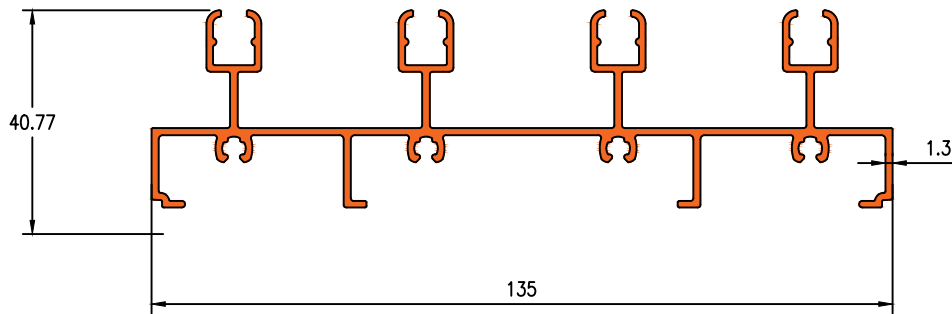

Die No.20074

0.453 KG/M

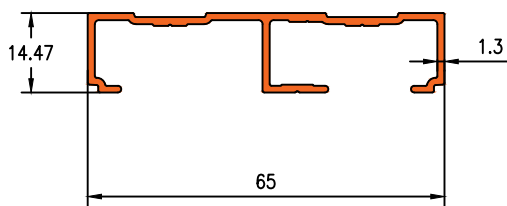

Die No.20073

0.577 KG/M

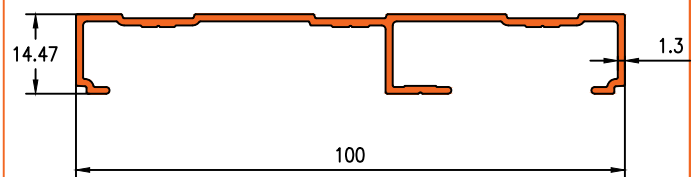

Die No.23105

0.793 KG/M

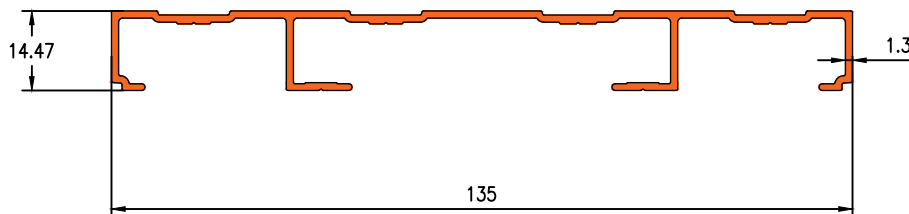



Die No.20081

0.667 KG/M

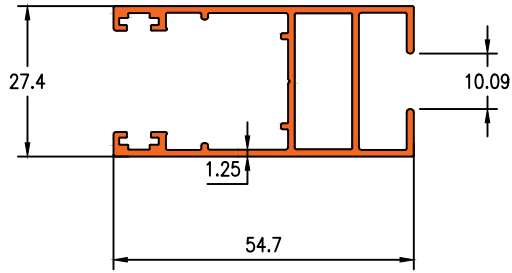

Die No.20079

0.634 KG/M

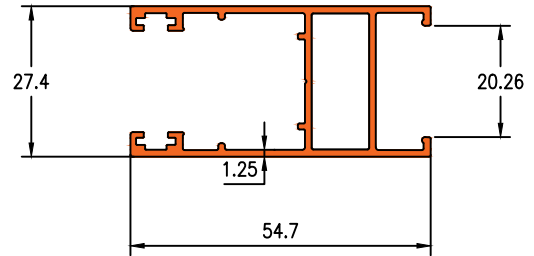

Die No.20082

0.600 KG/M

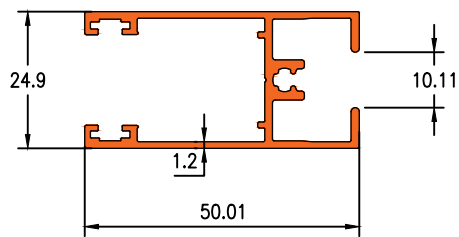

Die No.20080

0.558 KG/M

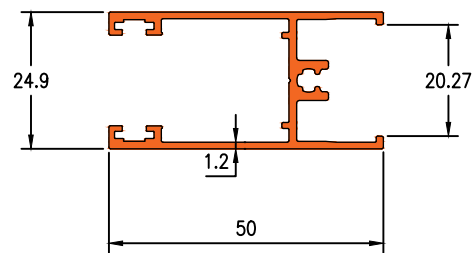

Die No.23067

0.801 KG/M

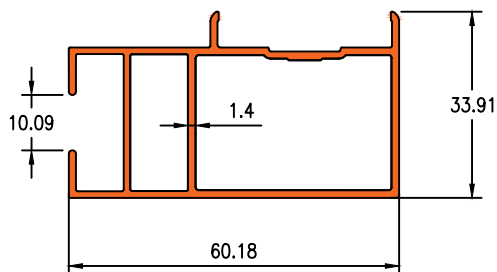

Die No.23065

1.051 KG/M

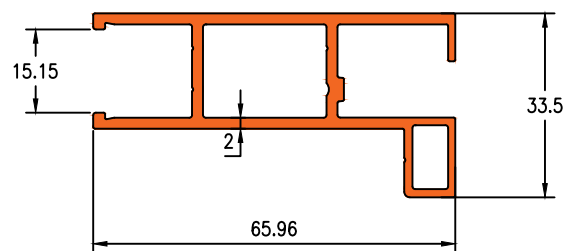



Die No.16455

0.533 KG/M

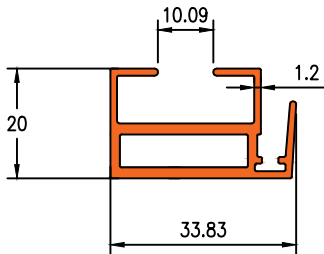

Die No.16457

0.500 KG/M

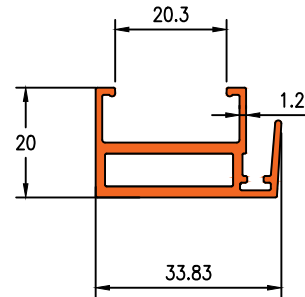

Die No.16454

1.216 KG/M

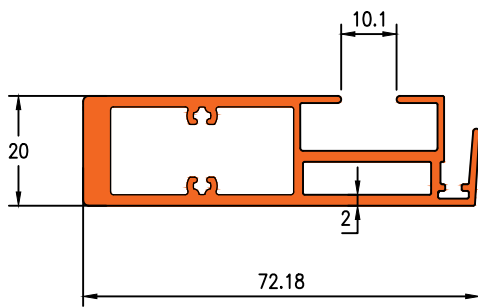

Die No.16456

1.182 KG/M

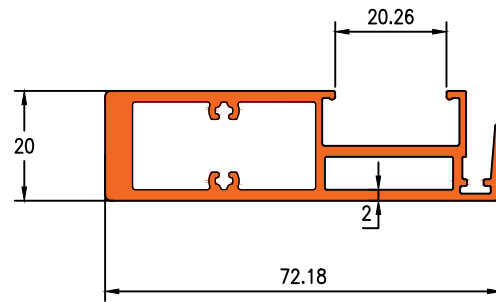

Die No.23066

0.318 KG/M

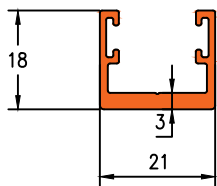

Die No.20078

0.299 KG/M

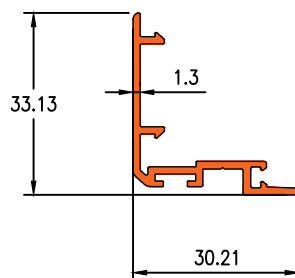

Die No.20077

0.296 KG/M

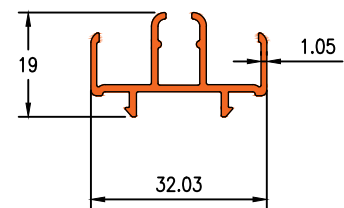

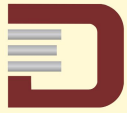

Die No.20075

0.265 KG/M

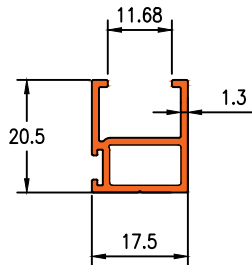

Die No.20076

0.265 KG/M

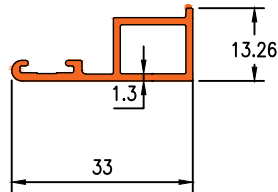

Die No.21078

0.119 KG/M

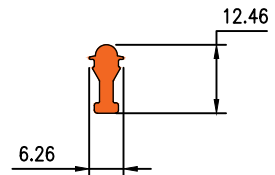

Die No.16458

0.142 KG/M

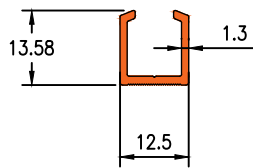

Die No.16453

0.513 KG/M

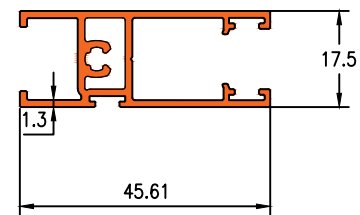



Die No. 16218

1.387KG/M

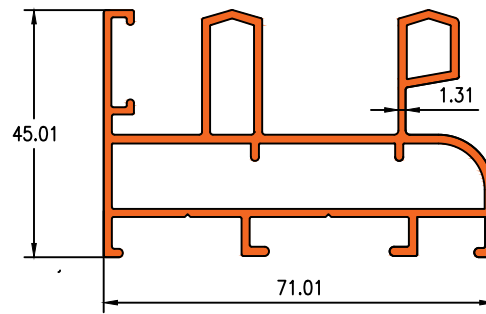

Die No. 16205

2.006KG/M

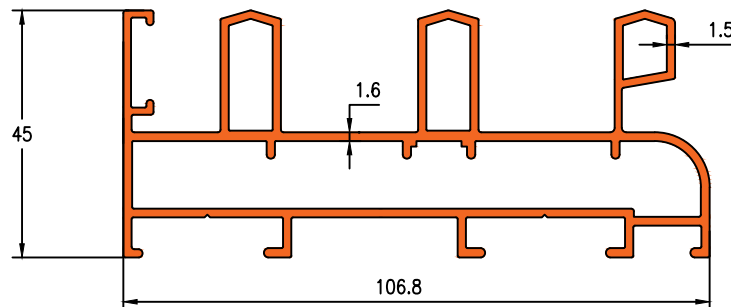

Die No. 19901

1.985KG/M

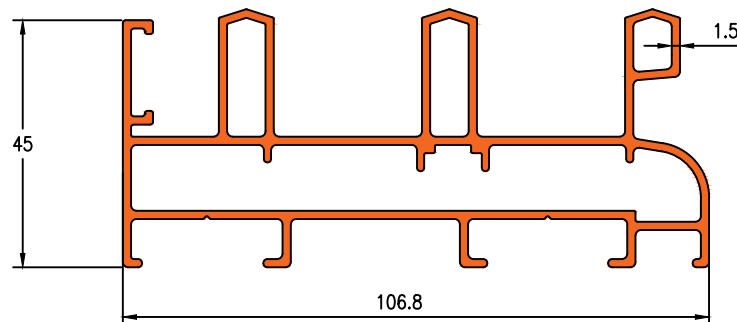

Die No. 16206

0.826KG/M

Die No. 19444

0.267KG/M

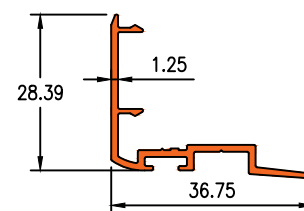
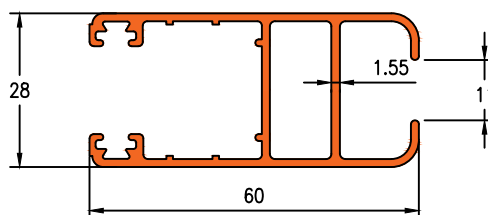

CLIP : 19444 & 2709



Die No. 2812

0.770KG/M

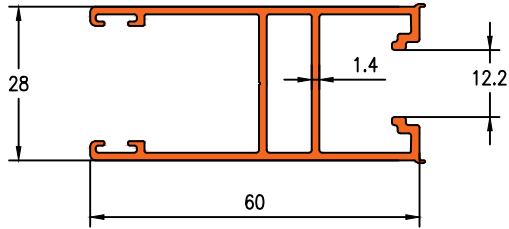

Die No. 2813

0.690KG/M

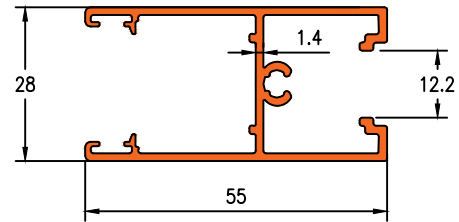

Die No. 2814

0.834KG/M

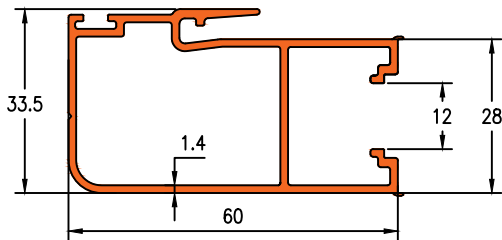

Die No. 2815

1.141KG/M

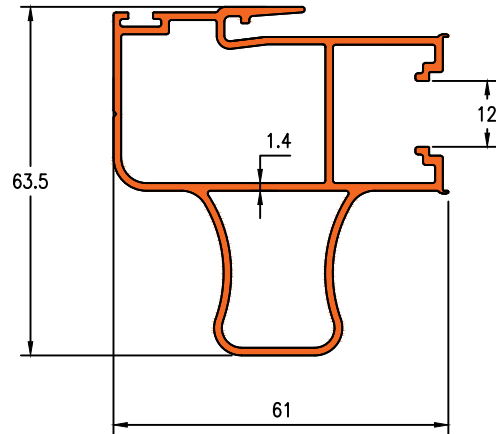



Die No. 16719

1.352KG/M

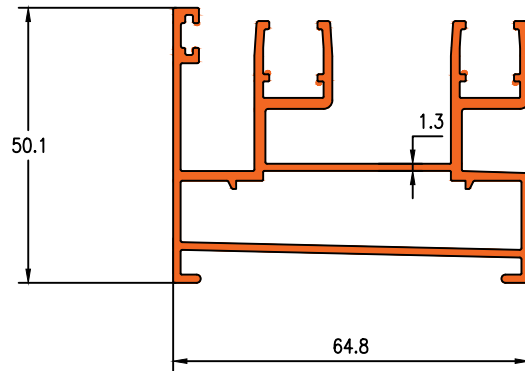

Die No. 16720

1.986KG/M

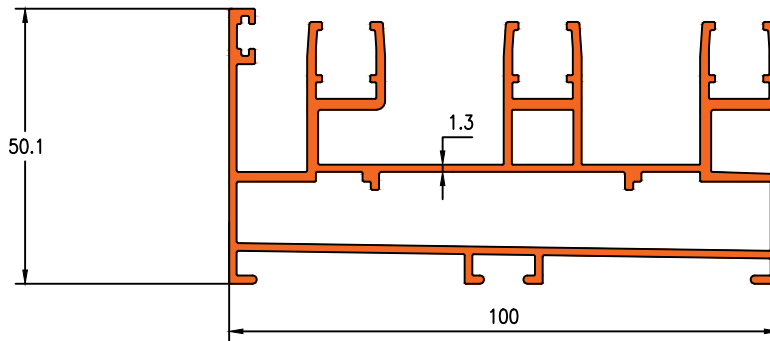

Die No. 22110

2.488KG/M

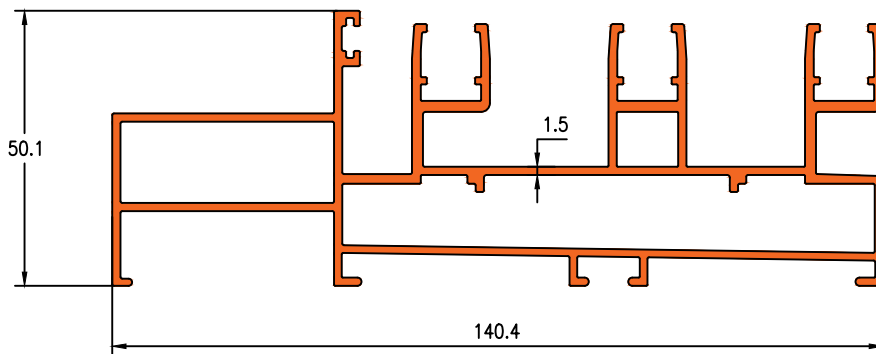

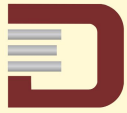

Die No. 2903

0.491KG/M

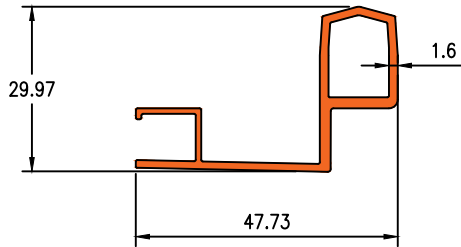

Die No. 2901

1.097KG/M

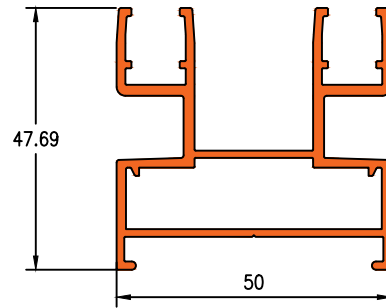

Die No. 2902

1.723KG/M

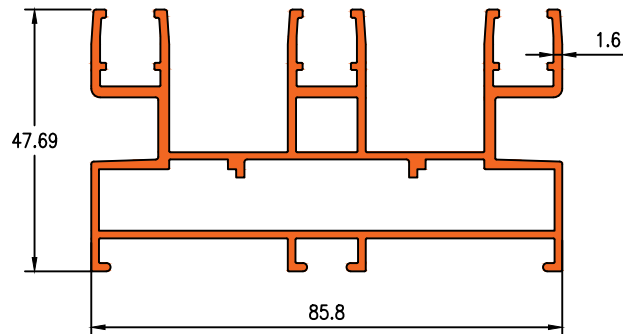

Die No. 2904

0.877KG/M

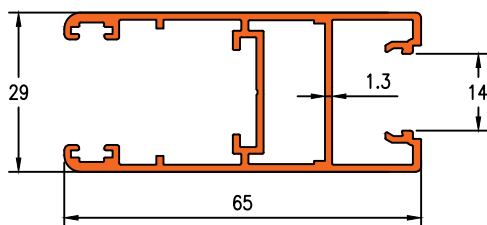

Die No. 2905

0.892KG/M

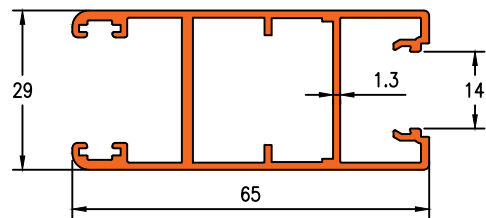

Die No. 2906

0.820KG/M

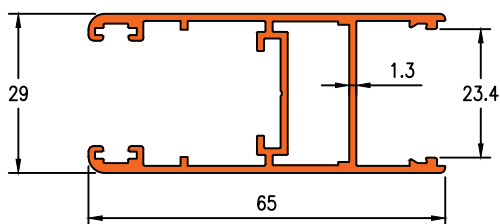

Die No. 2907

0.836KG/M

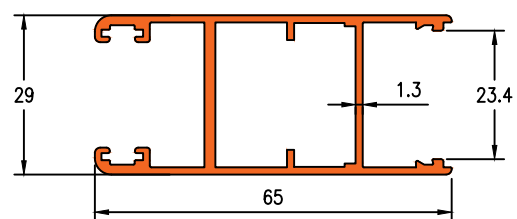

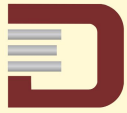

Die No. 16721

0.586KG/M

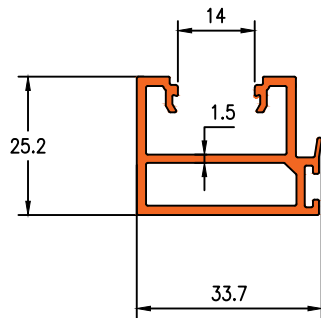

Die No. 16722

1.244KG/M

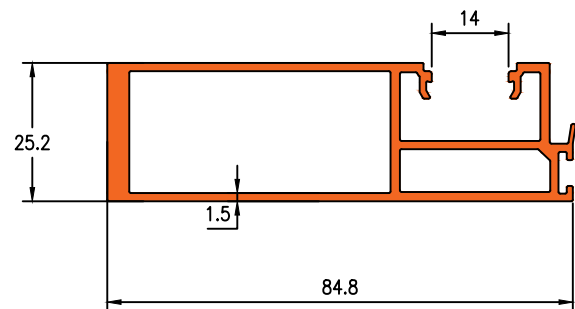

Die No. 2908

0.148KG/M

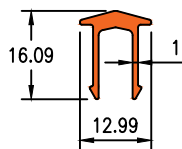

Die No. 2909

0.357KG/M

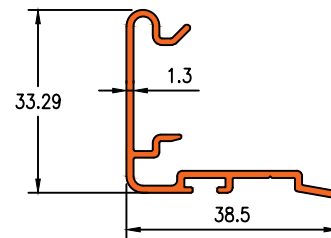

Die No. 2910

0.275KG/M

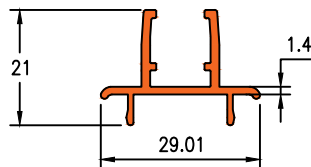

Die No. 2911

0.282KG/M

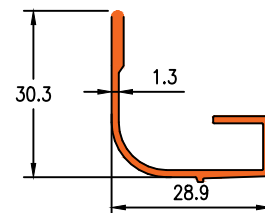

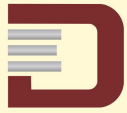

Die No. 16009

0.080KG/M

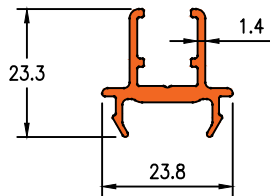

Die No. 16004

1.312KG/M

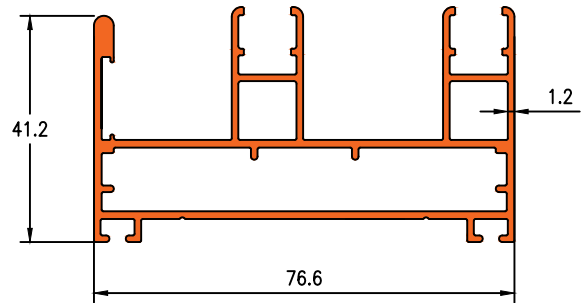

Die No. 16005

1.760KG/M

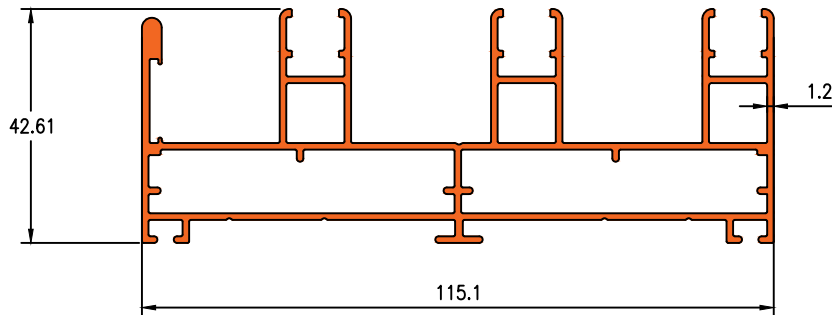

Die No. 16539

2.345KG/M

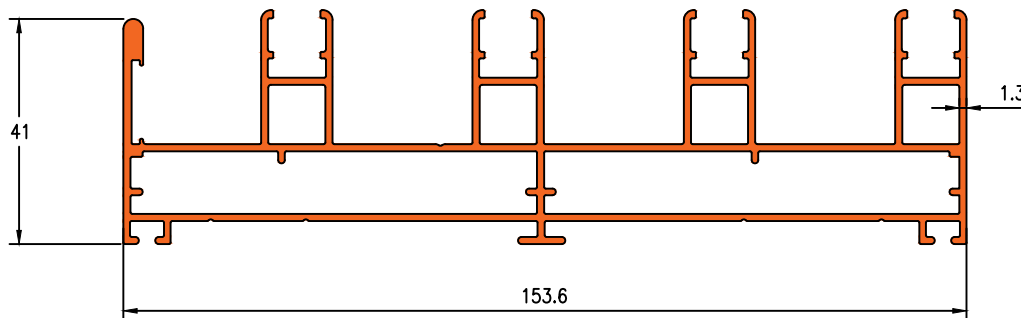

Die No. 16006

0.863 KG/M

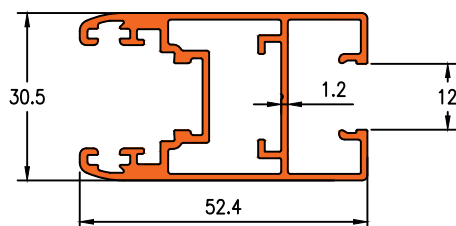

Die No. 16008

0.182KG/M

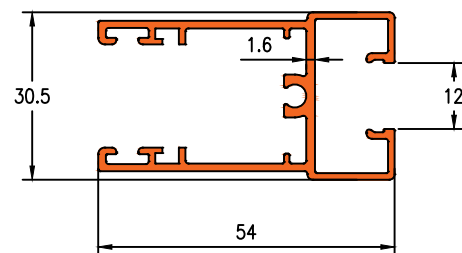



Die No. 16541

1.020KG/M

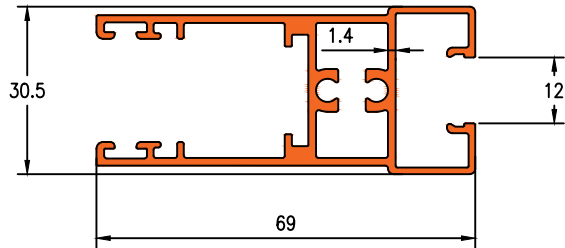

Die No. 16007

0.685KG/M

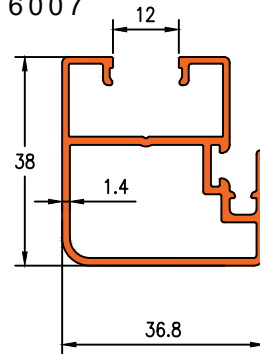

Die No. 23020

0.543KG/M

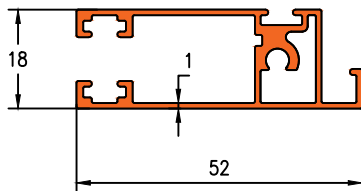

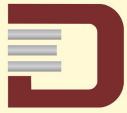

Die No.16181

1.023KG/M

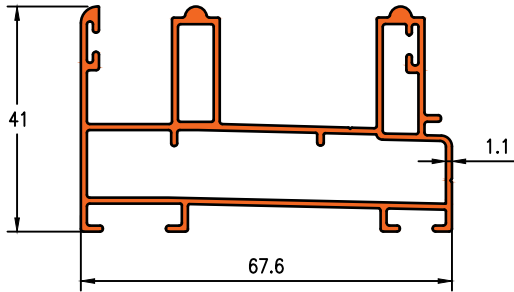

Die No.16014

1.451KG/M

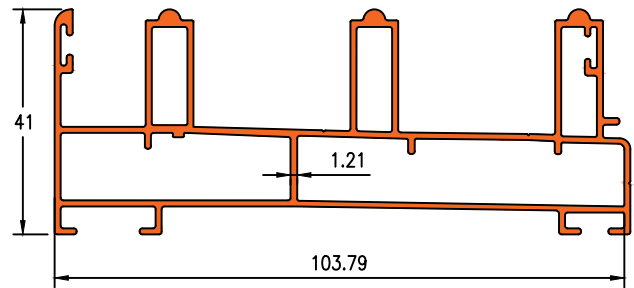

Die No.16134

1.956KG/M

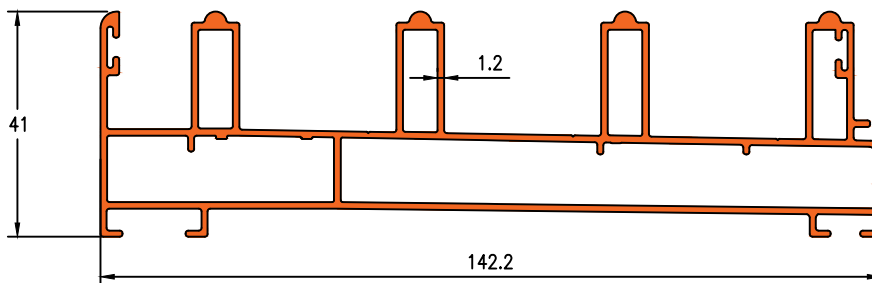

Die No. 7128

1.057KG/M

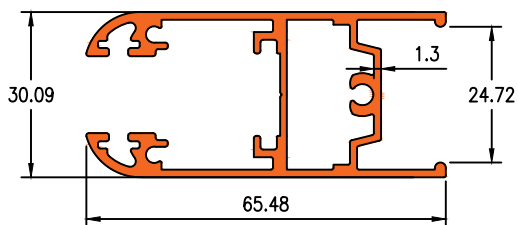

Die No. 7129

0.812KG/M

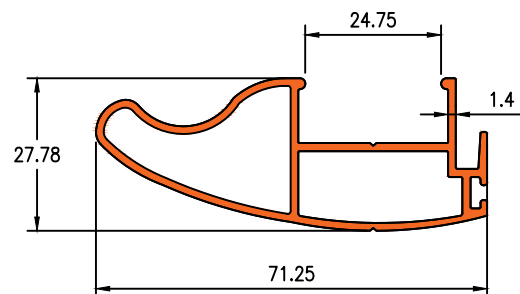

Die No. 16013

0.543KG/M

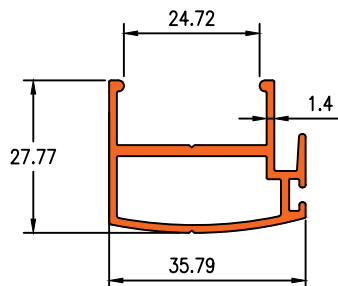

Die No. 16012

0.194KG/M

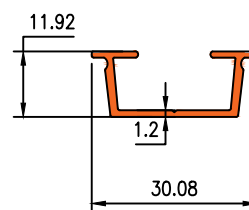

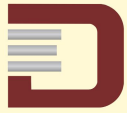

Die No. 19621

0.795KG/M

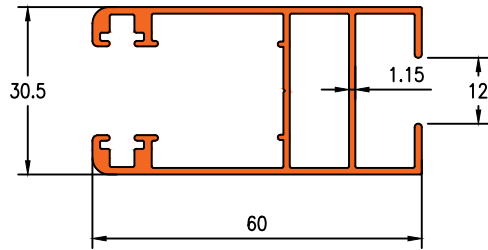

Die No. 19624

1.128KG/M

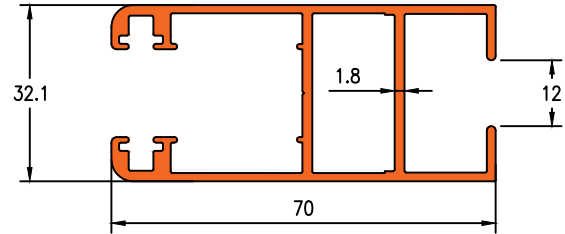

Die No. 19822

1.039KG/M

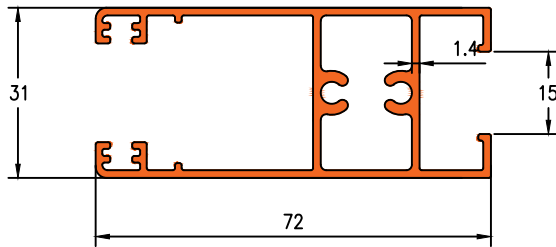

Die No. 19623

1.082KG/M

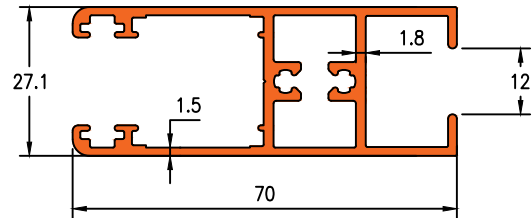

Die No. 16063

0.307KG/M

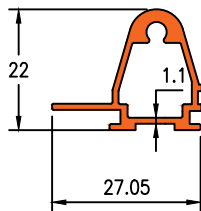

Die No. 19622

0.318KG/M

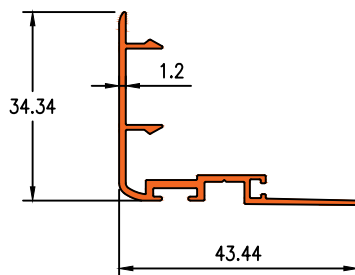

Die No. 19619

0.304KG/M

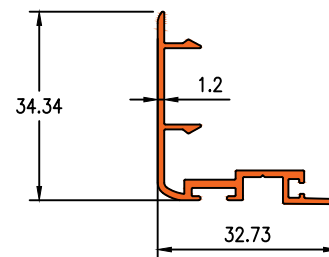

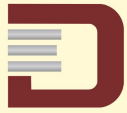

Die No.16604

2.015 KG/M

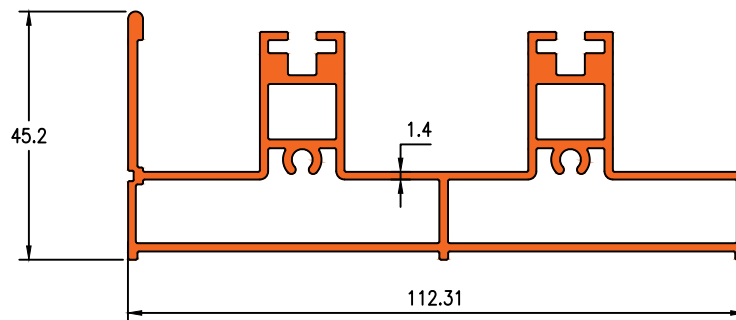

Die No.16613

1.696 KG/M

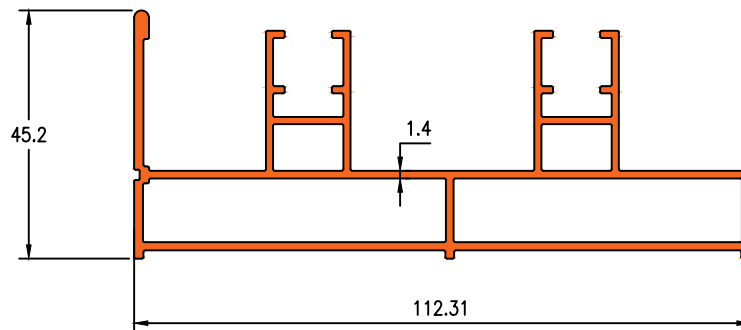

Die No.16605

1.787 KG/M

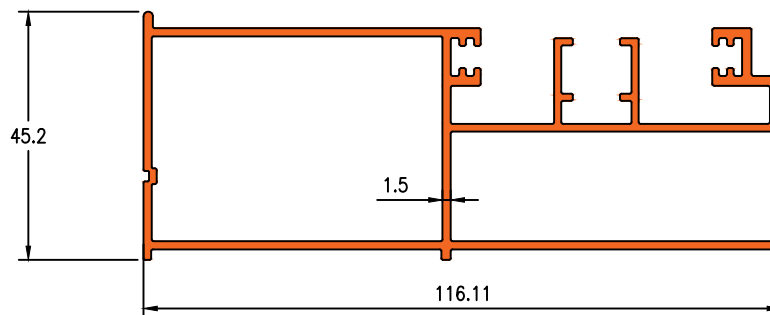

Die No.16617

2.585 KG/M

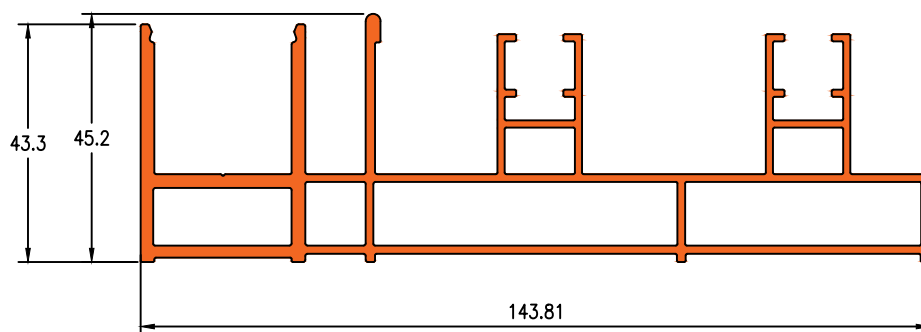



Die No.16618

2.821 KG/M

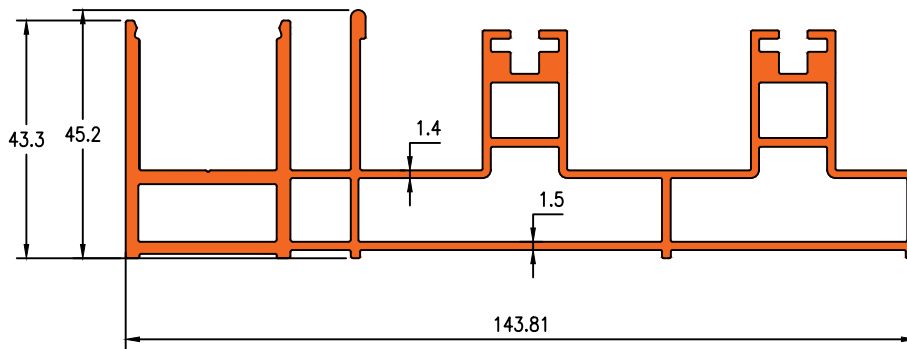

Die No. 16614

1.066KG/M

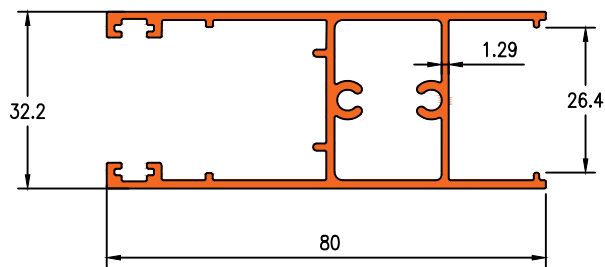

Die No. 16611

1.010KG/M

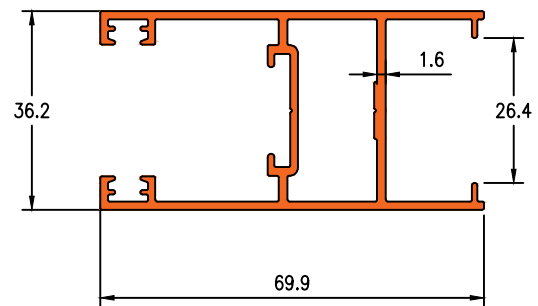

Die No. 16607

0.623KG/M

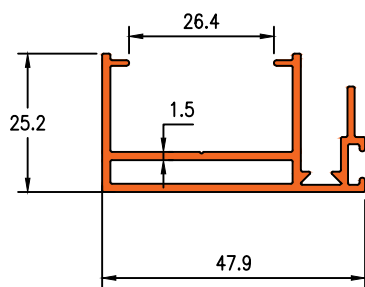

Die No. 16612

1.206 KG/M

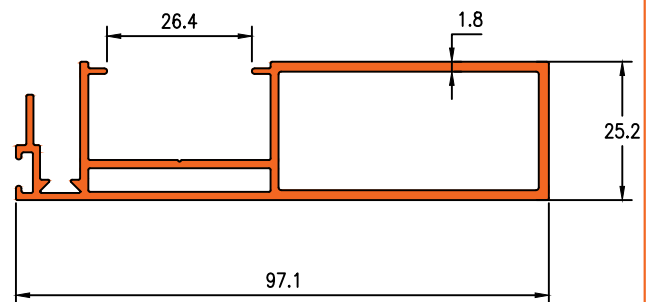

Die No. 23020

0.543 KG/M

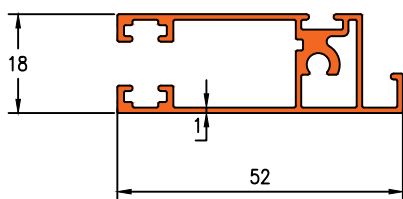

Die No. 16610

0.206 KG/M

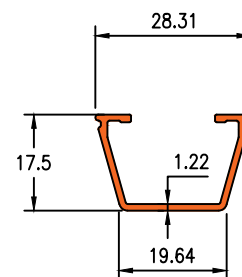



Die No. 16608

0.933KG/M Die No. 16609

0.120 KG/M

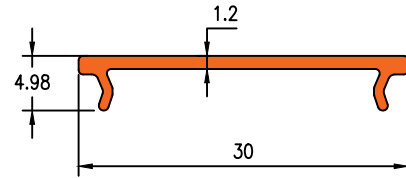
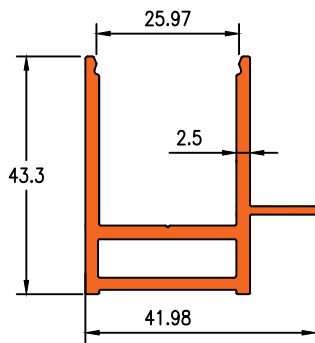



Die No.23187

2.003 KG/M

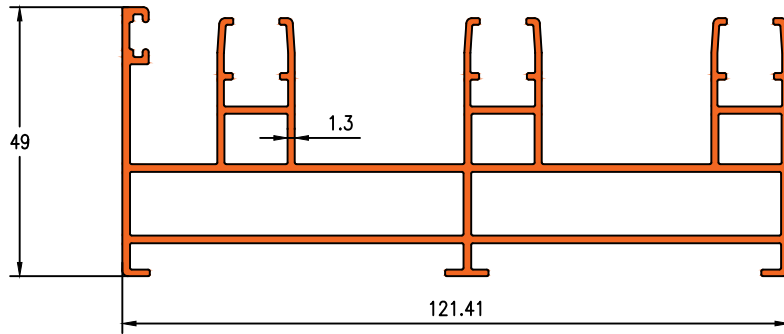

Die No.22109

2.455 KG/M

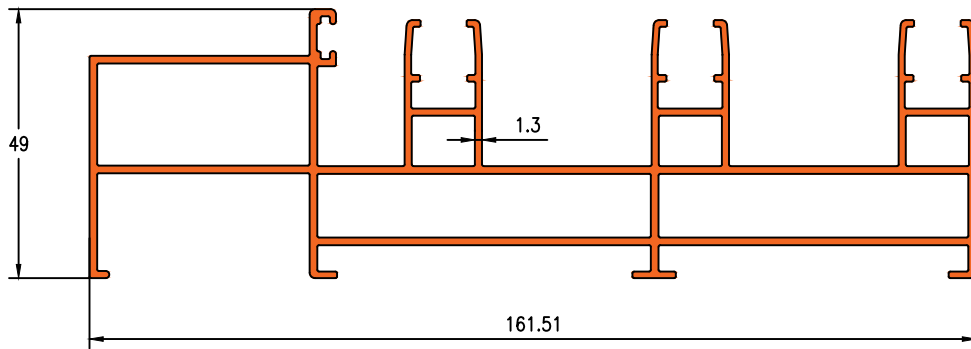



Die No. 16066

1.450KG/M

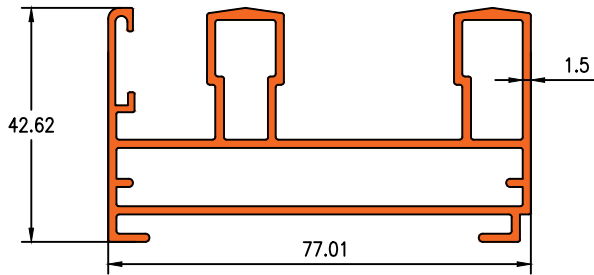

Die No. 19452

1.827KG/M

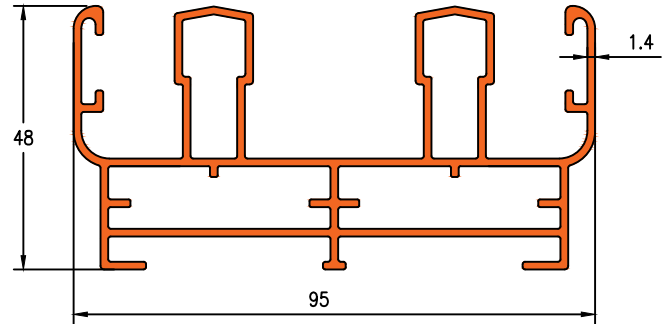

Die No. 19640

2.137 KG/M

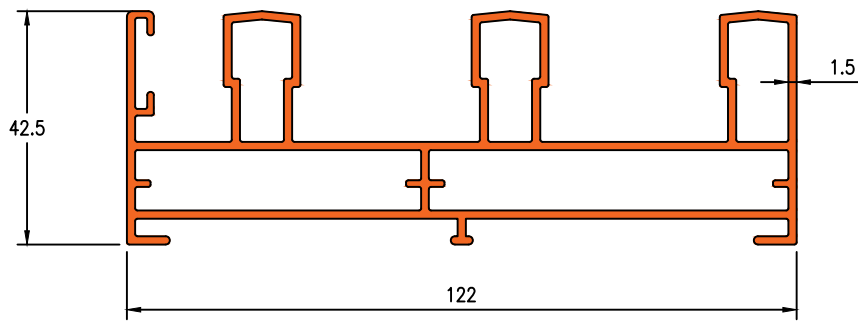

Die No. 16192

2.365KG/M

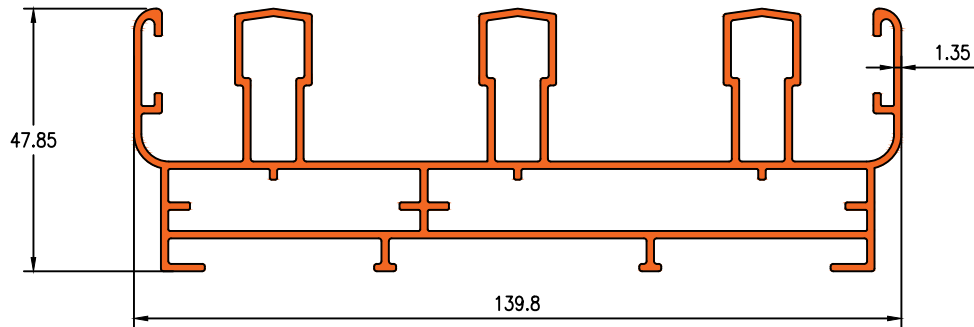

Die No. 16648

2.749KG/M

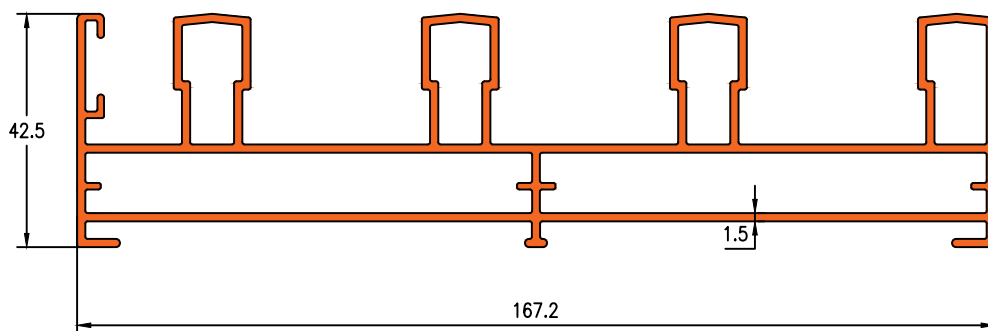



Die No. 19443

0.988KG/M

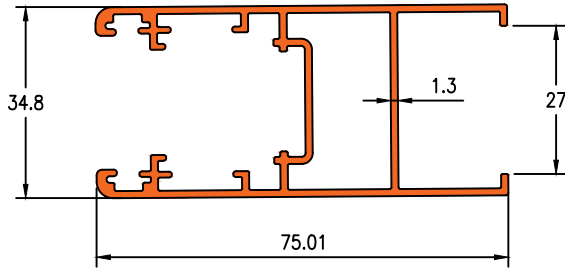

Die No. 16193

1.035KG/M

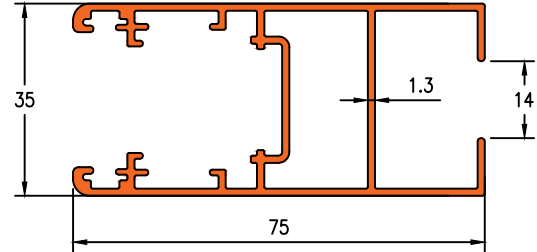

Die No. 16716

1.147KG/M

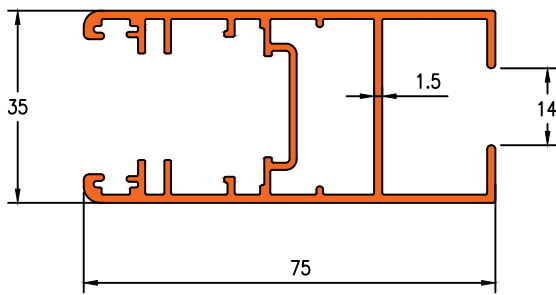

Die No. 16194

0.380KG/M

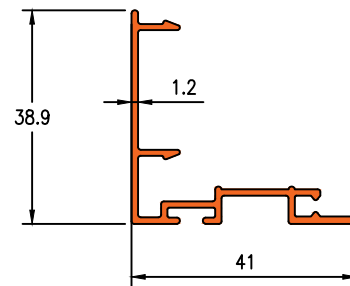

Die No. 20026

0.684KG/M

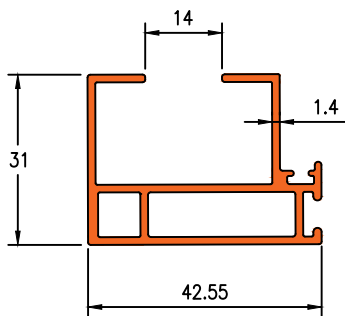

Die No. 20027

0.633KG/M

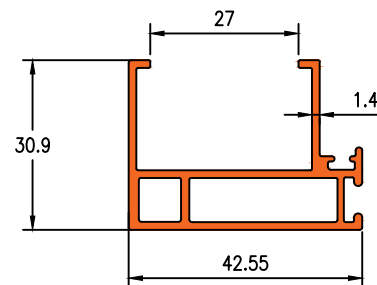

Die No. 16715

1.679KG/M

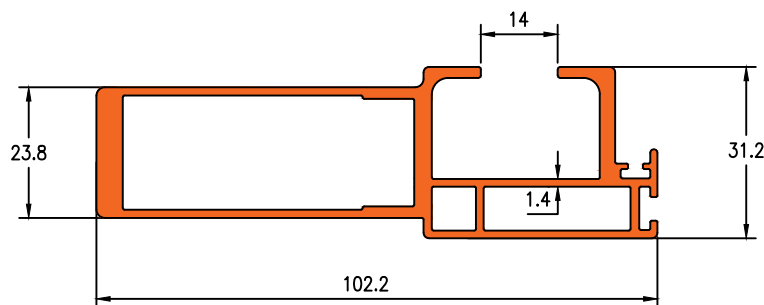



Die No. 16622

1.442KG/M

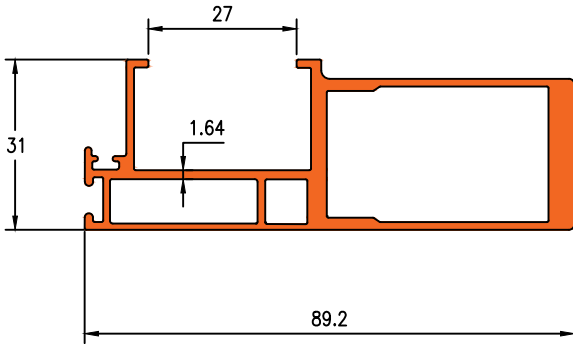

Die No. 16725

0.293KG/M

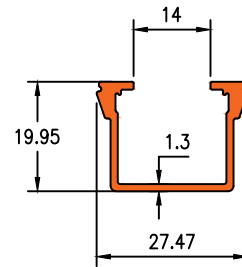

Die No. 20066

1.321KG/M

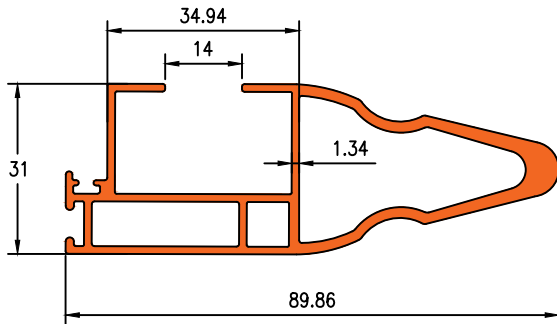

Die No. 21095

1.275KG/M

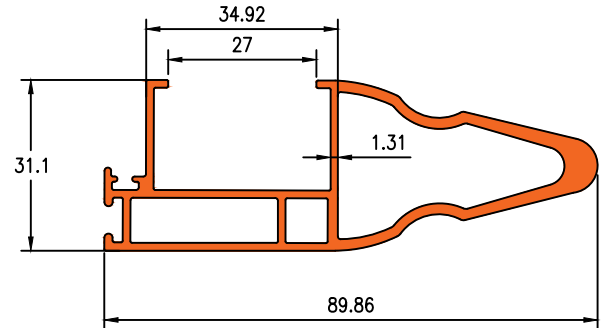



Die No. 21047

1.309KG/M

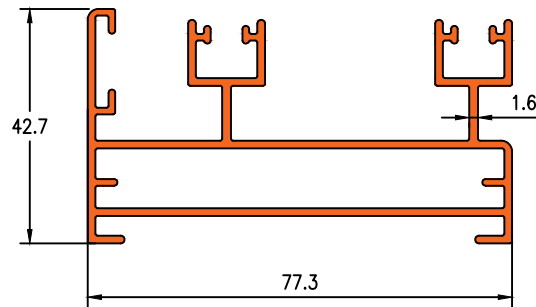

Die No. 21048

1.909KG/M

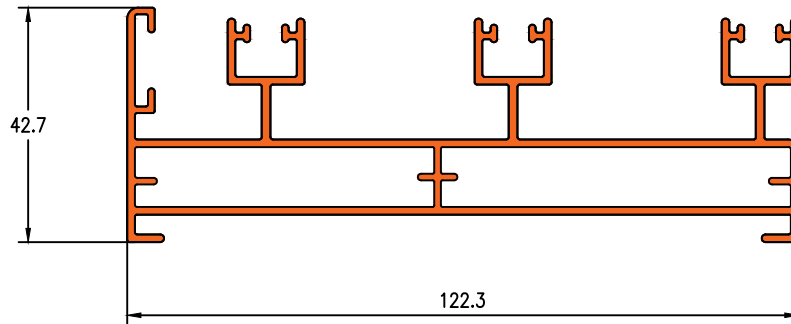

Enq No. 2508

2.312KG/M

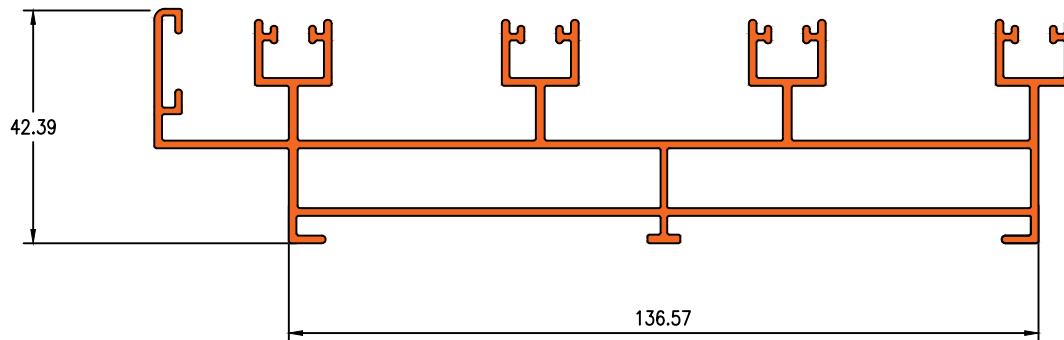

Die No. 20026

0.684KG/M

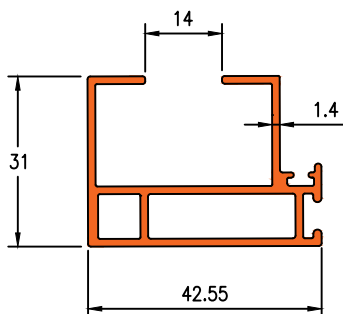

Die No. 20027

0.633KG/M

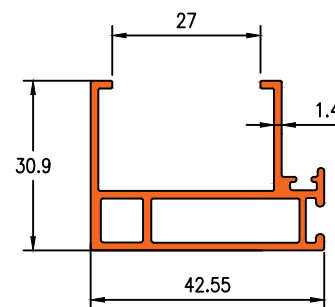

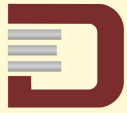

Die No. 20066

1.321KG/M

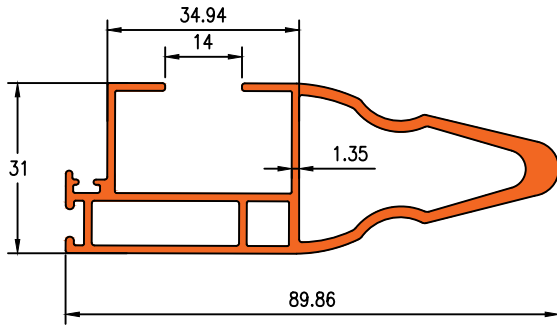

Die No. 21095

1.275KG/M

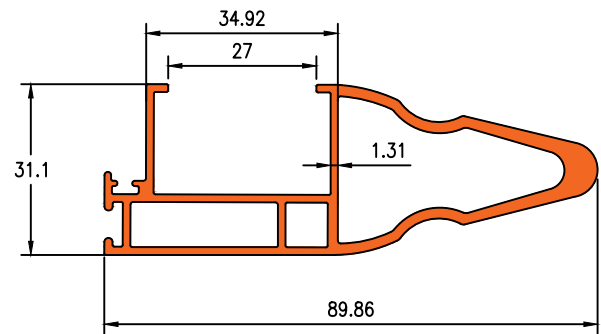

Die No. 16622

1.442KG/M

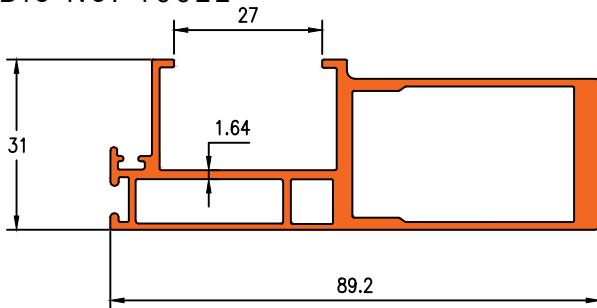

Die No. 16725

0.293KG/M

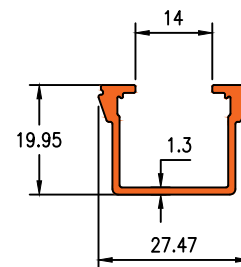

Die No. 16193

1.037KG/M

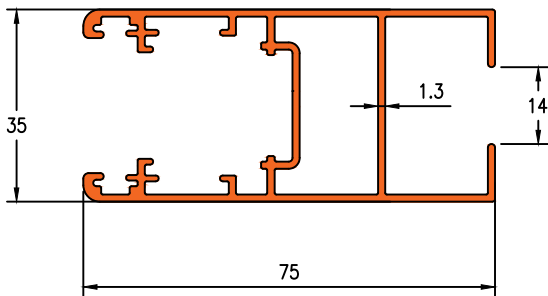

Die No. 19443

0.988KG/M

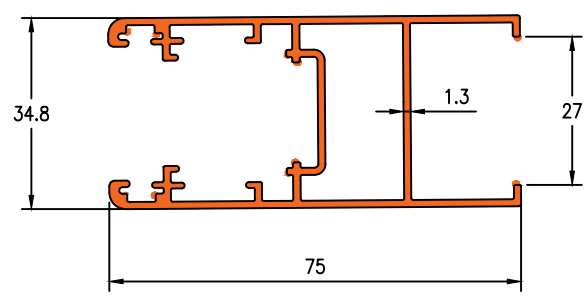

Die No. 16623

0.530KG/M

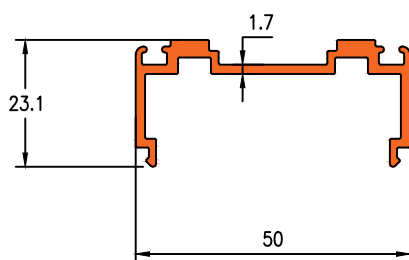

Die No. 16194

0.380KG/M

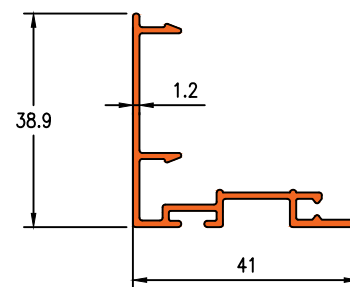



Die No. 28180

1.033KG/M

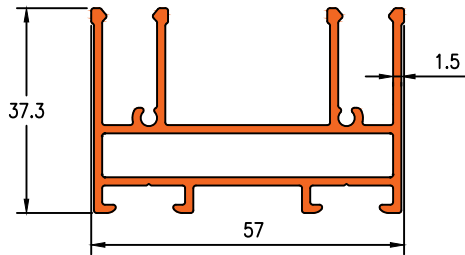

RAIL :- 28183

Die No. 28181

0.276KG/M

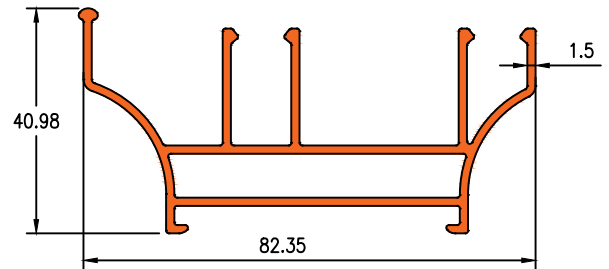

RAIL :- 28183

Die No. 28182

1.678KG/M

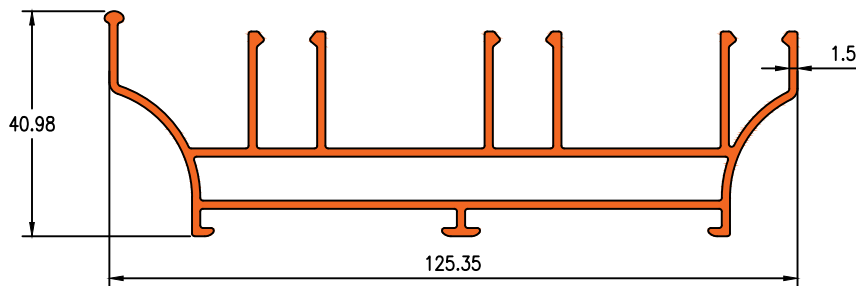

RAIL :- 28183

Die No. 28150

1.132KG/M

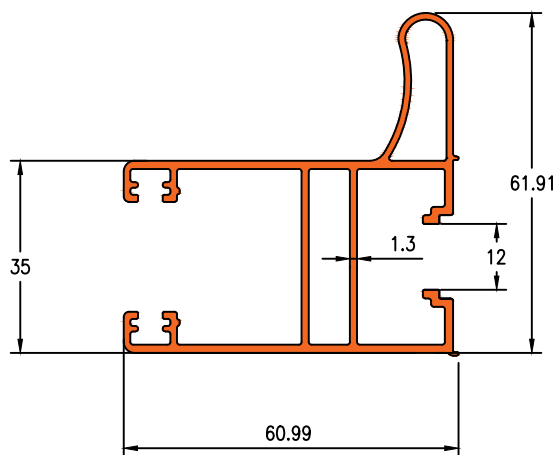

Die No. 28152

1.011KG/M

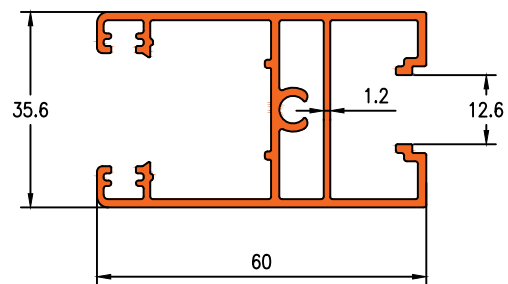

Die No. 28183

0.126KG/M

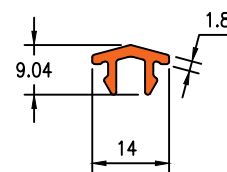



Die No. 28153

0.779KG/M

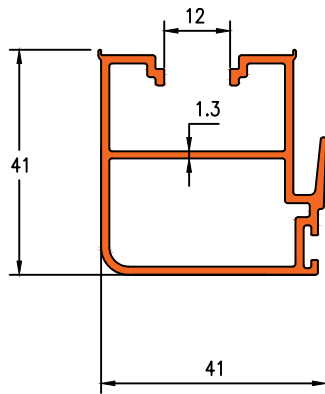

Die No. 28154

0.922KG/M

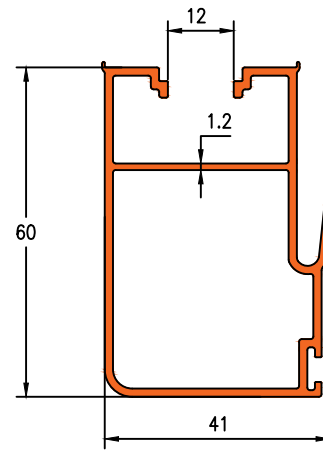

Die No. 28148

1.417KG/M

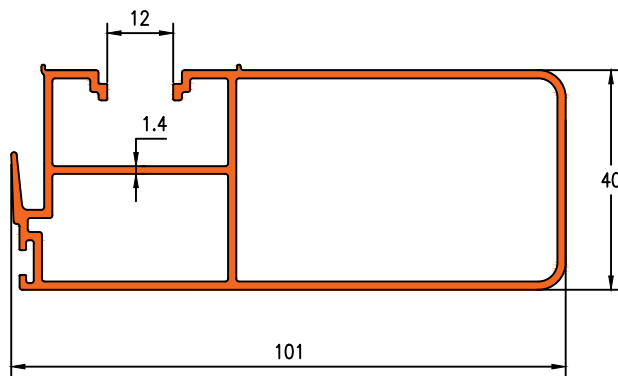

Die No. 28151

1.093KG/M

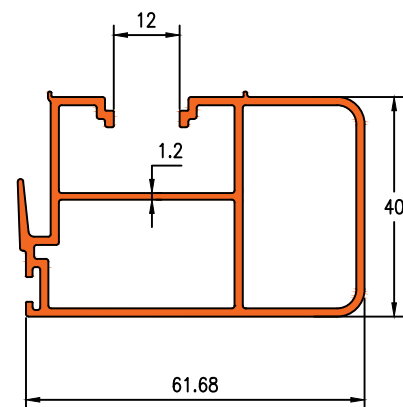



Die No. 16054

1.214KG/M

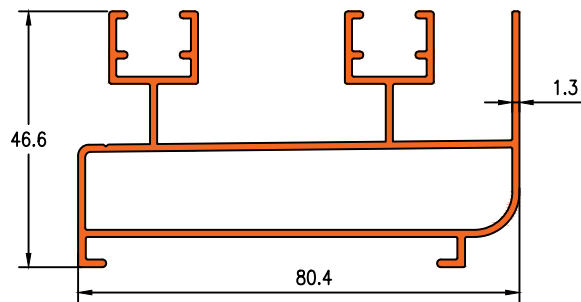

Die No. 16049

0.832KG/M

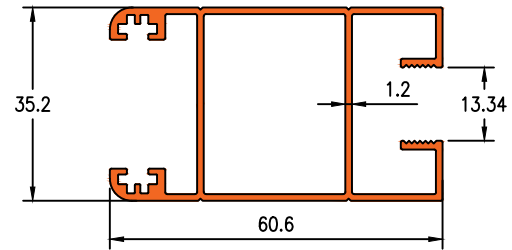

Die No. 16050

0.798KG/M

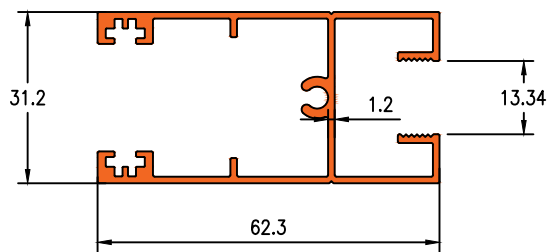

Die No. 16051

0.846KG/M

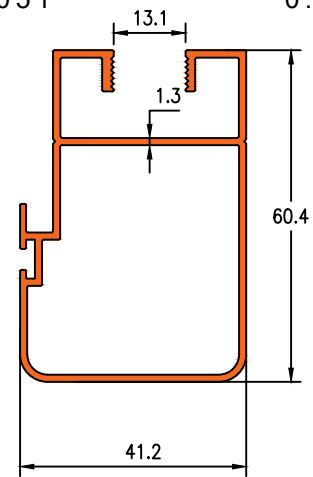



Die No. 16223

1.574KG/M

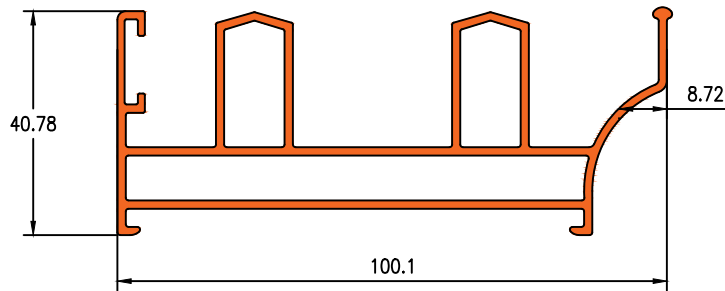

Die No. 16222

2.226KG/M

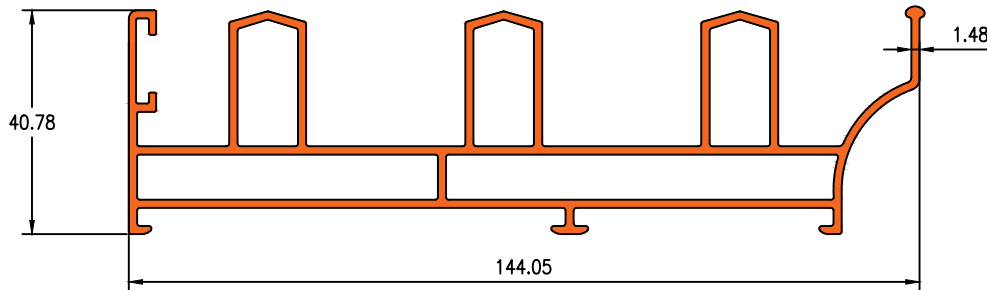

Die No. 16221

1.042KG/M

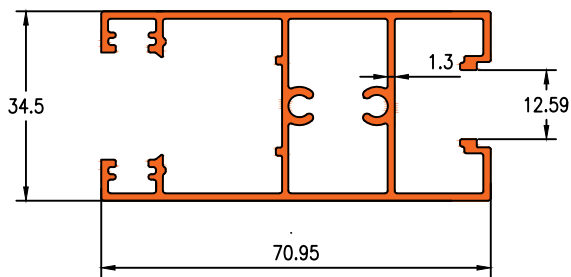

Die No. 16220

1.126KG/M

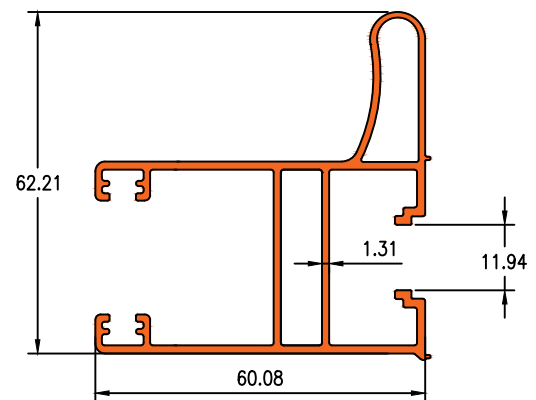

Die No. 2844

1.104KG/M

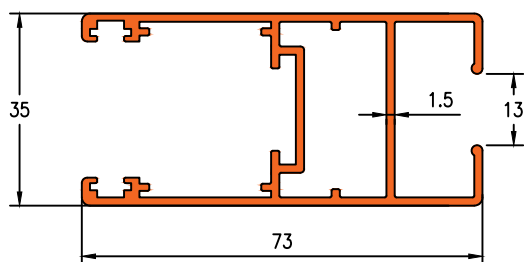

Die No. 16219

0.792KG/M

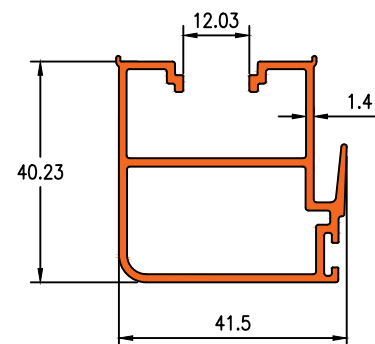



Die No. 2842

0.110KG/M

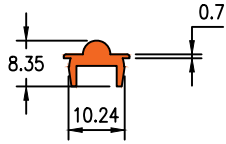

Die No. 2845

0.414KG/M

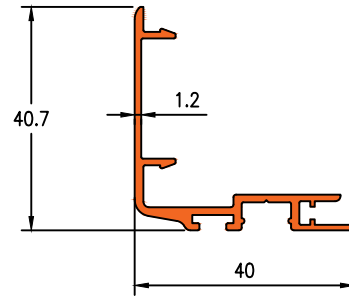

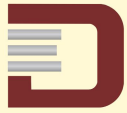

Die No. 16596

1.296KG/M

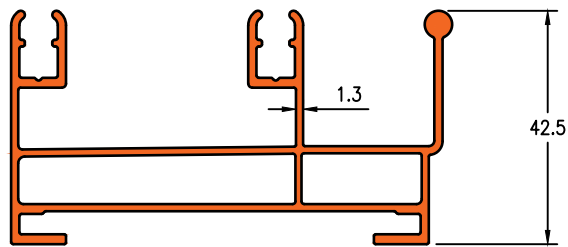

Die No. 16595

1.914KG/M

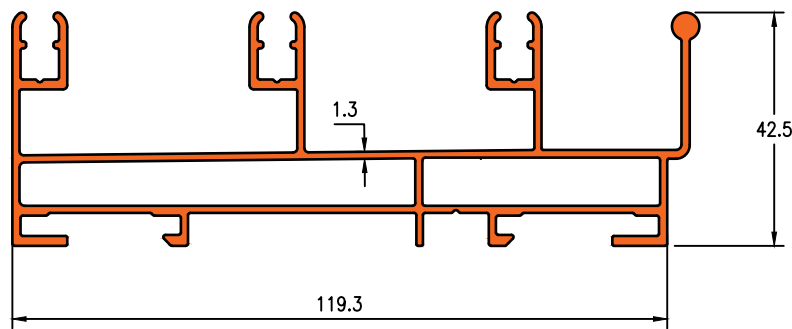

Die No. 21188

1.077KG/M

Die No. 21189

0.929 KG/M

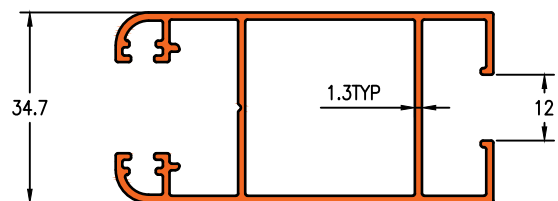
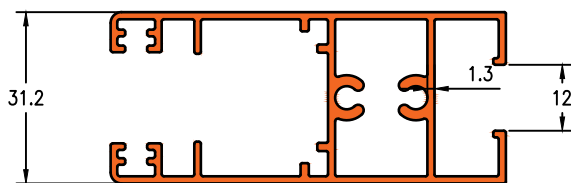

Die No. 16597

0.661 KG/M

Die No. 16598

1.053 KG/M

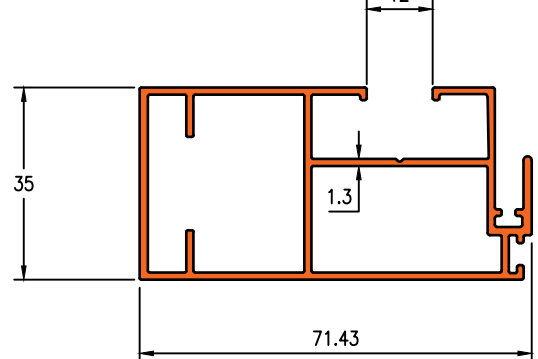
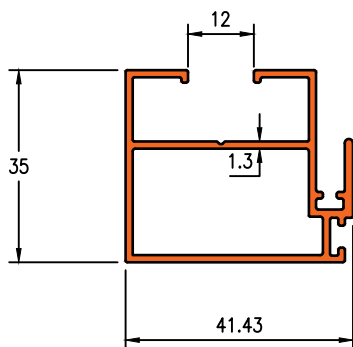

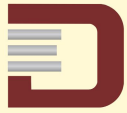

Die No. 16599

1.497KG/M

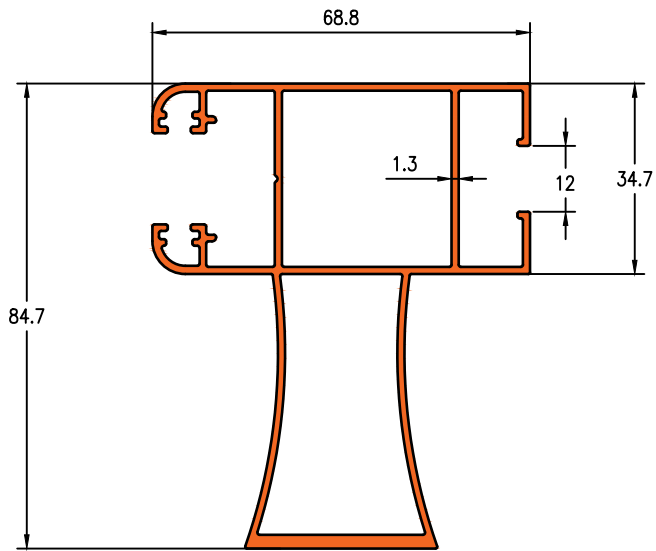

Die No. 21191

0.129 KG/M

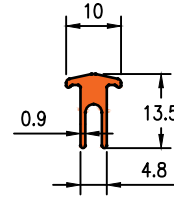

Die No. 21190

0.282 KG/M

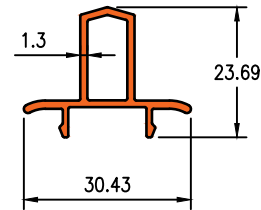

Enq No. 1864

0.667KG/M

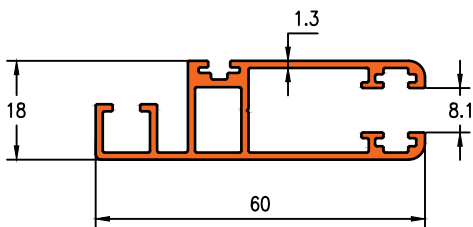

Enq No. 1865

0.208KG/M

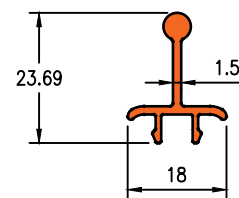

Enq No. 1867

0.476KG/M

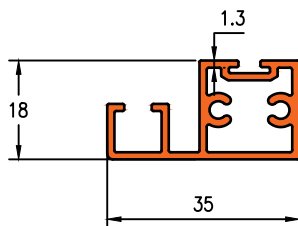

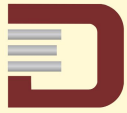

Enq No. 1970

1.045 KG/M

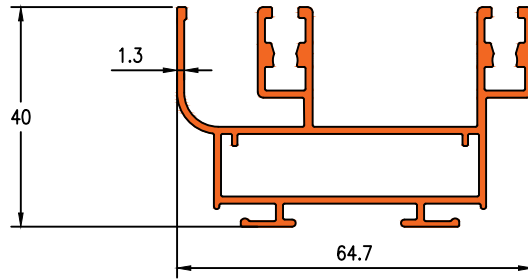

Enq No. 1965

0.873 KG/M

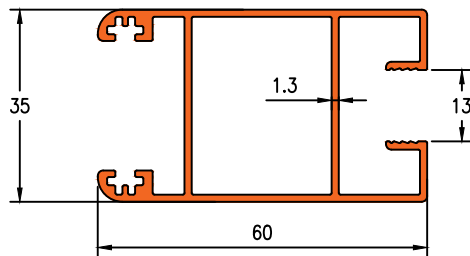

Enq No. 1963

1.161 KG/M

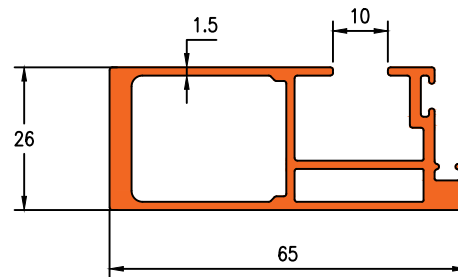

Enq No. 1964

0.835 KG/M

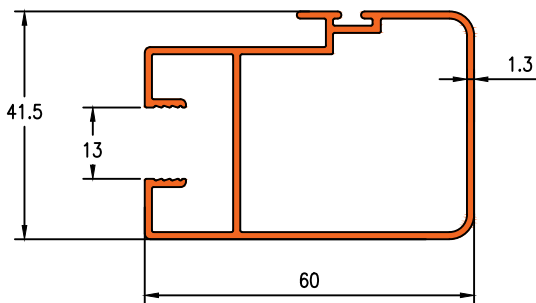

Enq No. 1968

1.164 KG/M

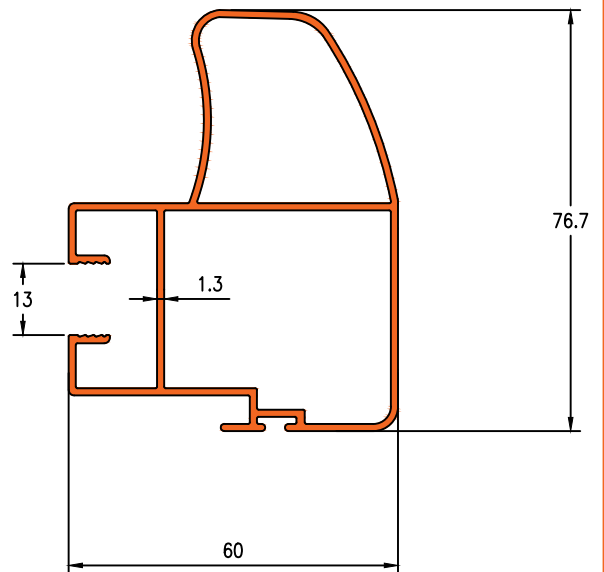

Enq No. 1966

0.757 KG/M

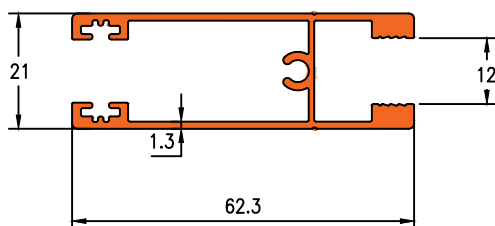



Enq No. 1969

0.972 KG/M

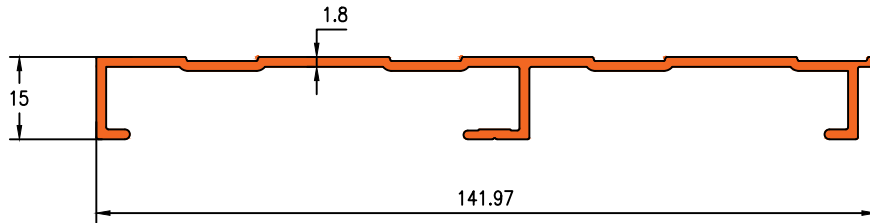

Enq No. 1967

1.085 KG/M

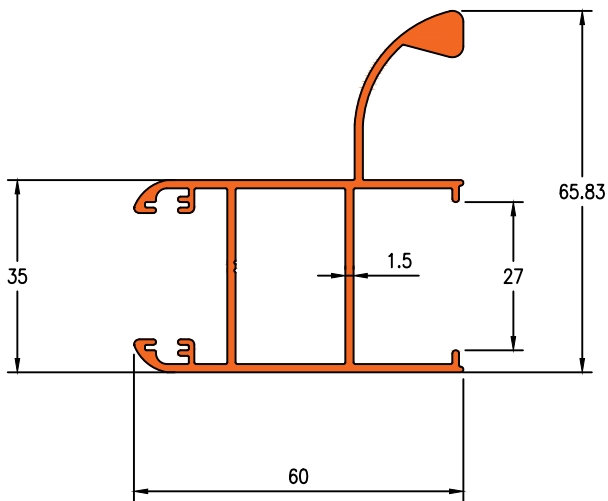



Enq No. 2018

1.667 KG/M

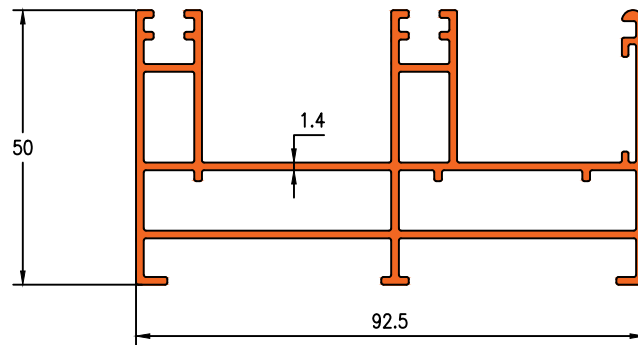

Enq No. 2020

1.460 KG/M

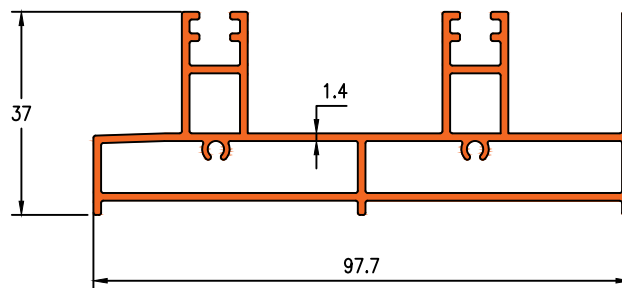

Enq No. 2019

2.401 KG/M

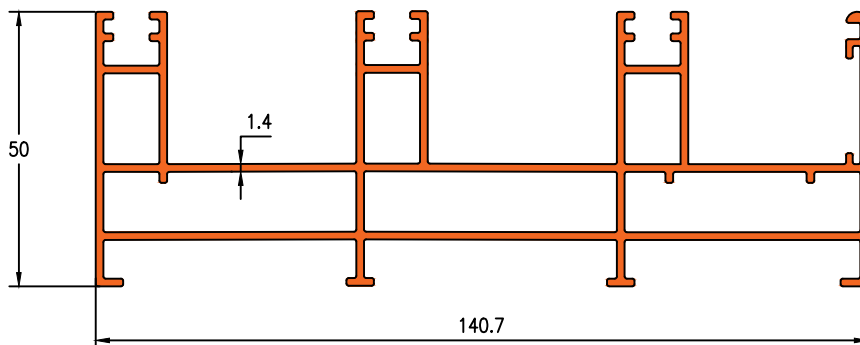

Enq No. 2021

2.086 KG/M

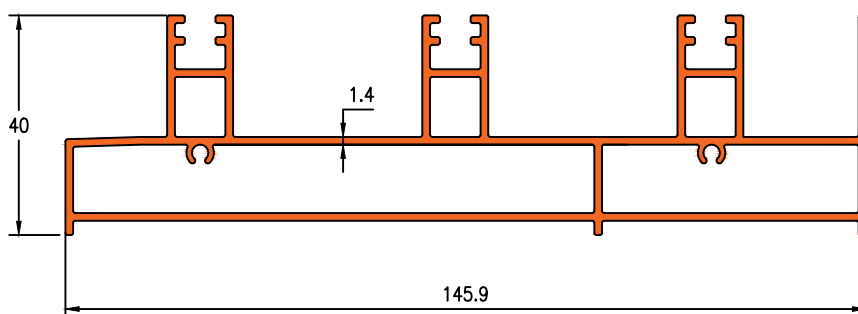



Enq No. 2014

1.105 KG/M

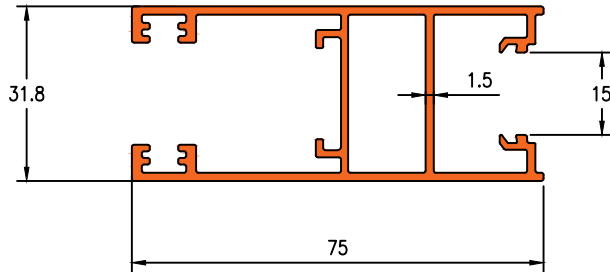

Enq No. 2015

1.016 KG/M

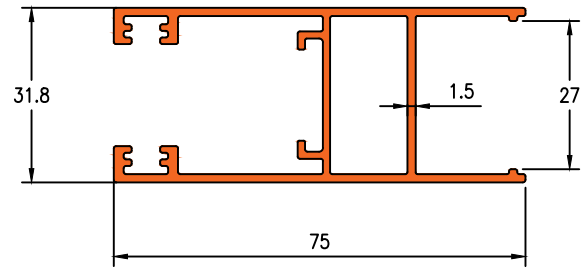

Enq No. 2016

0.810 KG/M

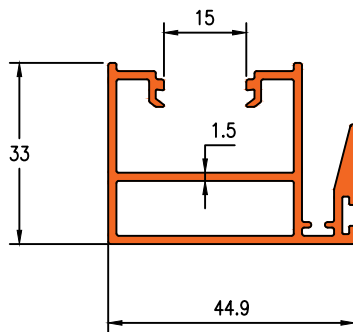

Enq No. 2017

1.260 KG/M

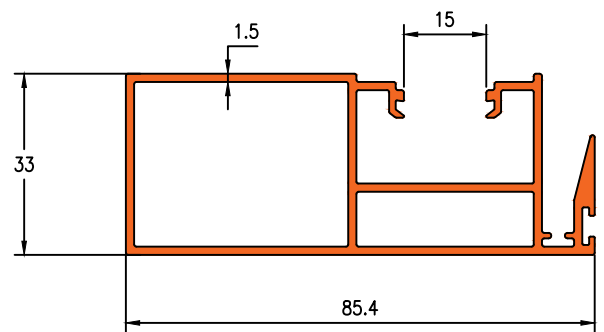



Die No. 5167

1.354KG/M

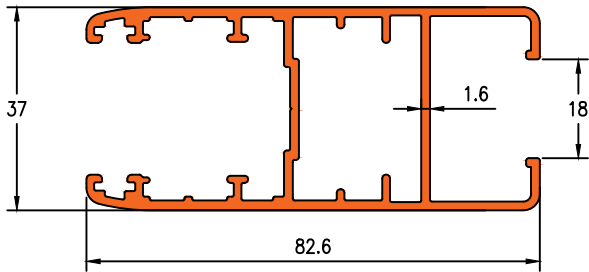

Die No. 19380

1.615KG/M

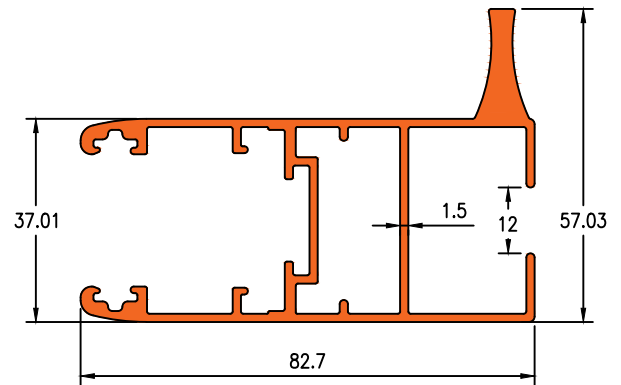

Die No. 5168

1.315KG/M

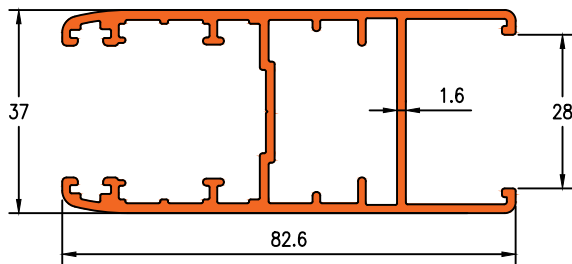

Die No. 5154

1.371KG/M

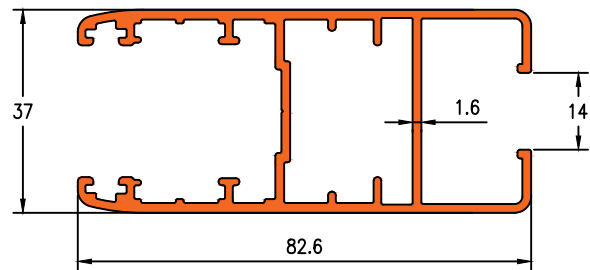

Die No. 5166

2.254KG/M

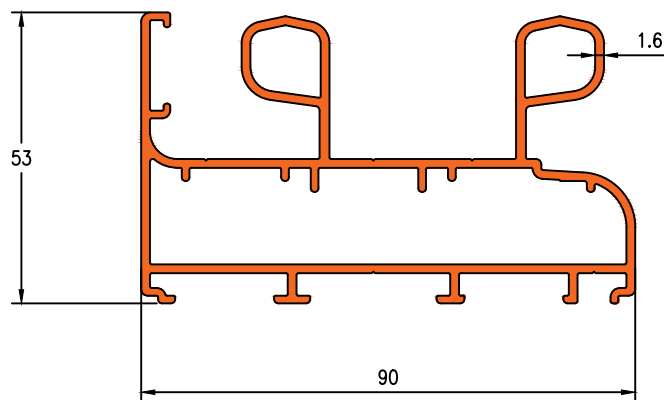



Die No. 7080

2.158KG/M

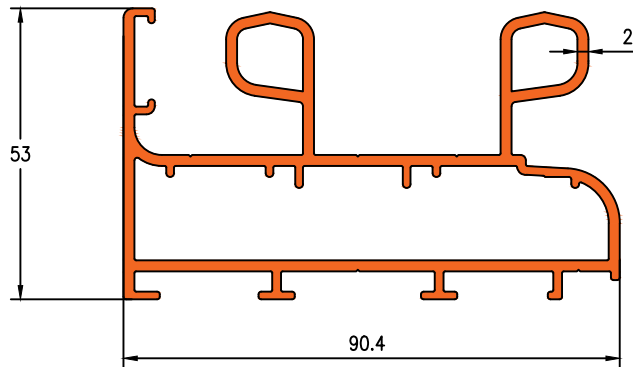

Die No. 6293

2.523KG/M

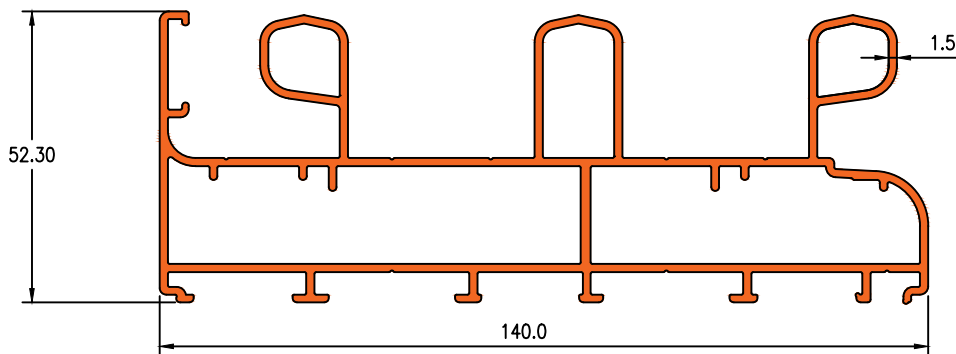

Die No. 7079

0.295KG/M

Die No. 7081

0.744KG/M

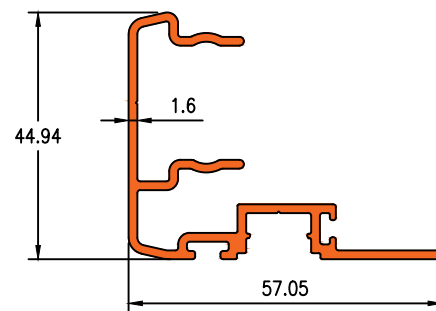
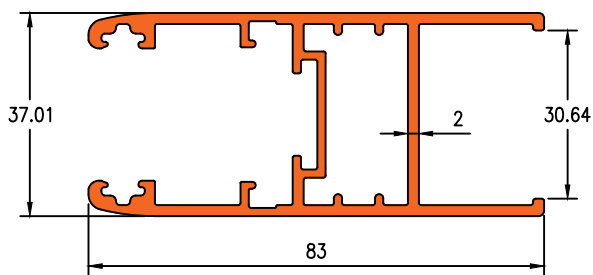

Die No. 7083

0.527KG/M

Die No. 7085

0.061KG/M

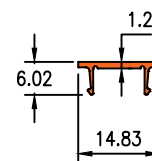
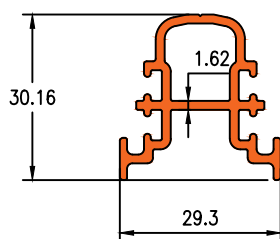



Die No. 3703

0.310KG/M

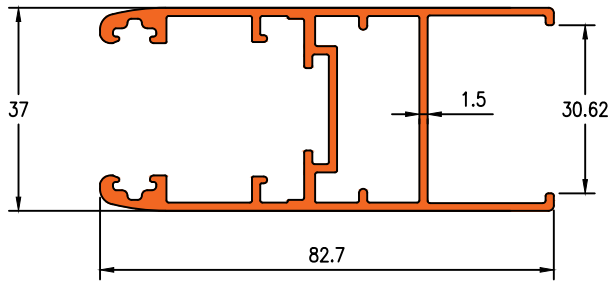

Die No. 3704

0.342KG/M

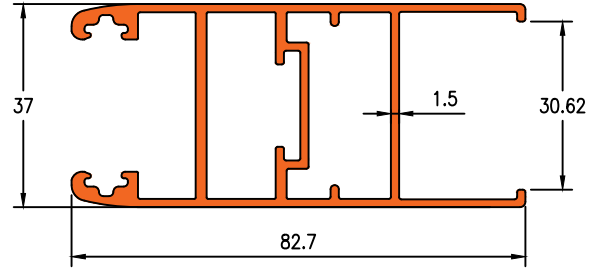

Die No. 3705

0.329KG/M

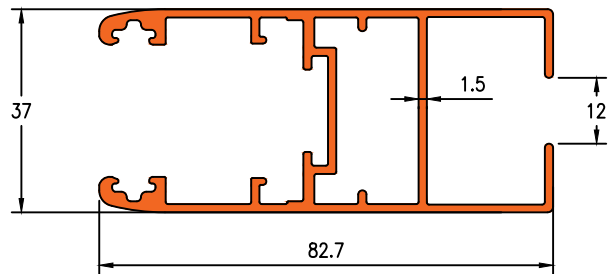

Die No. 3706

0.361KG/M

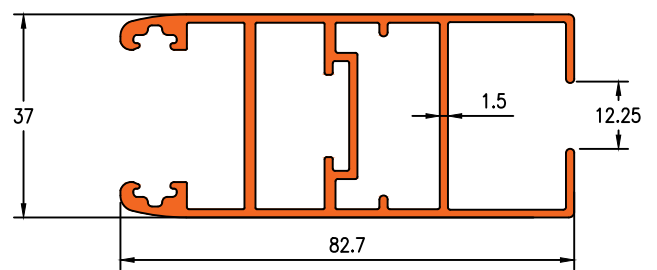

Die No. 3707

0.689KG/M

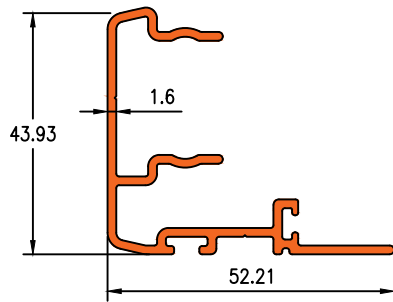

Die No. 3708

0.314KG/M

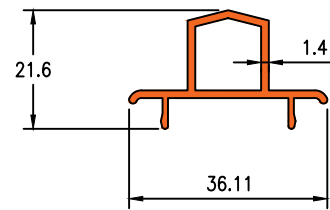

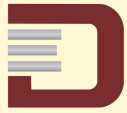

Die No. 19709

1.115KG/M

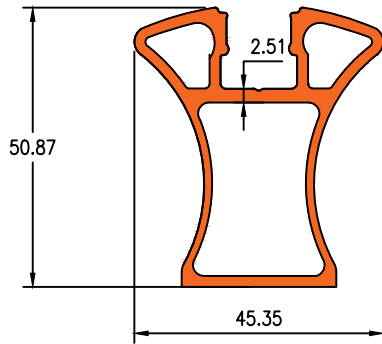

Die No. S4969

0.819KG/M

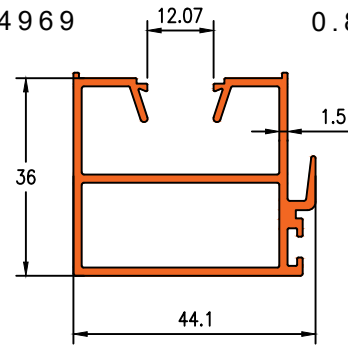

Die No. 7082

0.426KG/M

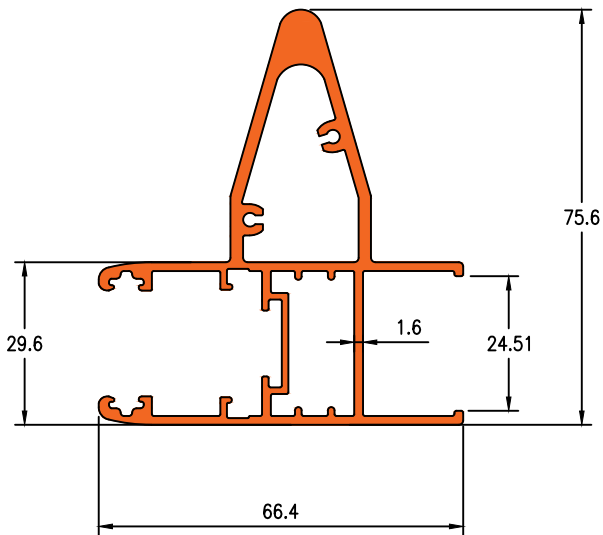



Die No. 16643

1.895KG/M

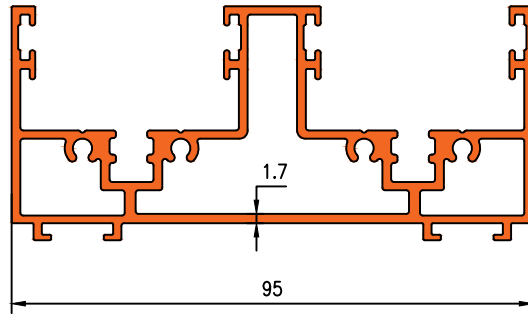

Die No. 16644

1.222KG/M

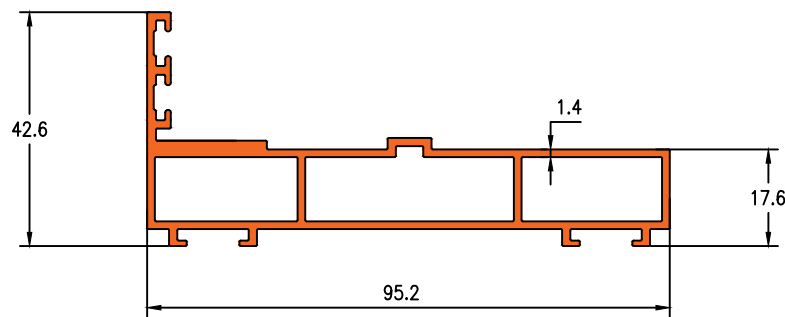

Die No.21222

0.837KG/M

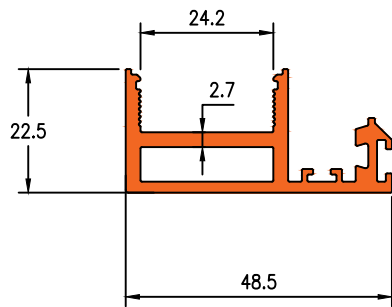

Die No.21223

1.374 KG/M

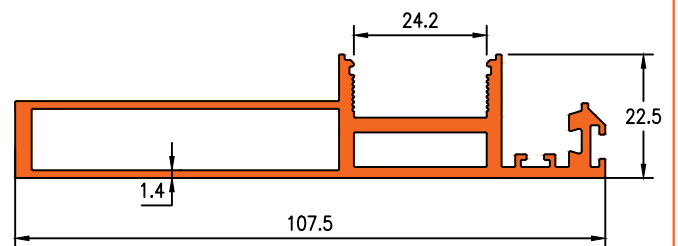

Die No.21221

0.493KG/M

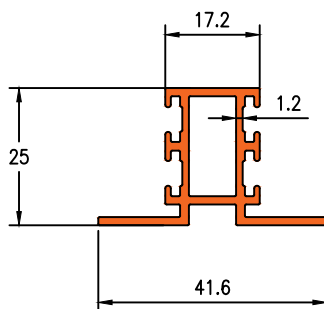

Die No.21220

0.211KG/M

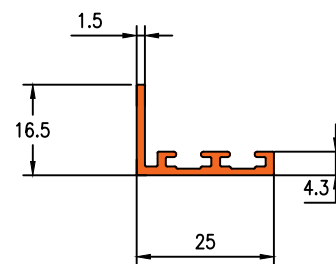



Die No.21219

0.507KG/M

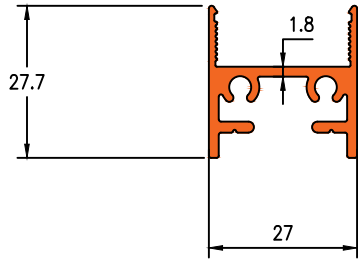

Die No.21218

0.971KG/M

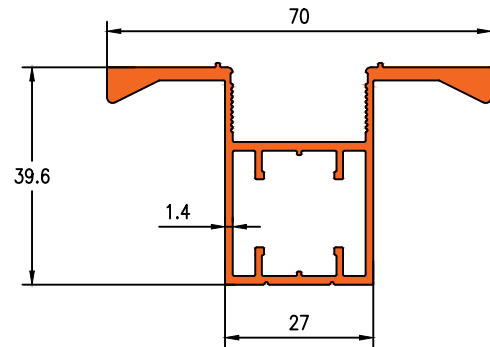



Die No. 16442

0.929 KG/M

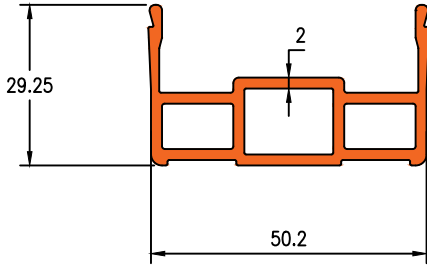

Die No. 16443

0.453 KG/M

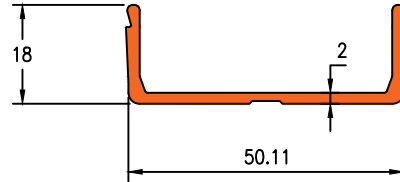

Die No. 16444

2.350 KG/M

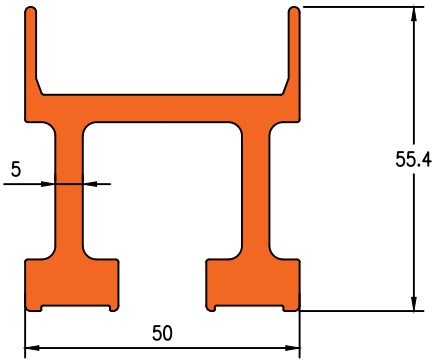

Die No. 16445

0.318 KG/M

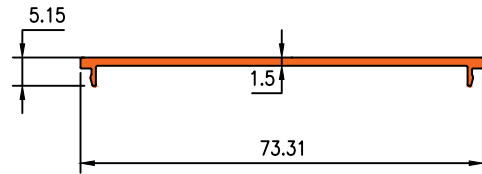

Die No. 16446

2.974 KG/M

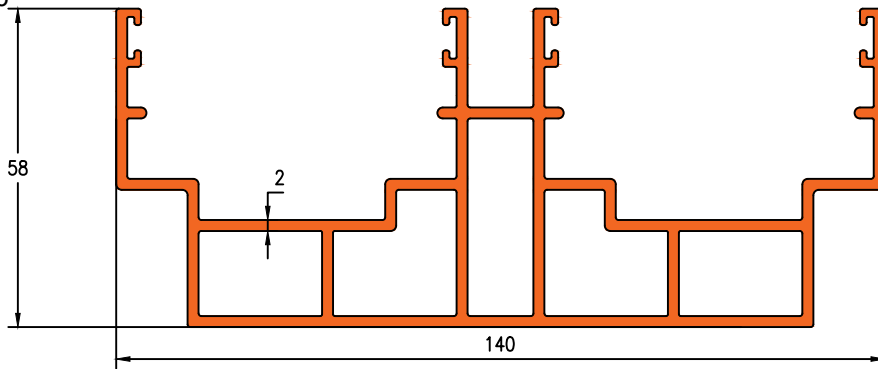

Die No. 16447

3.641 KG/M

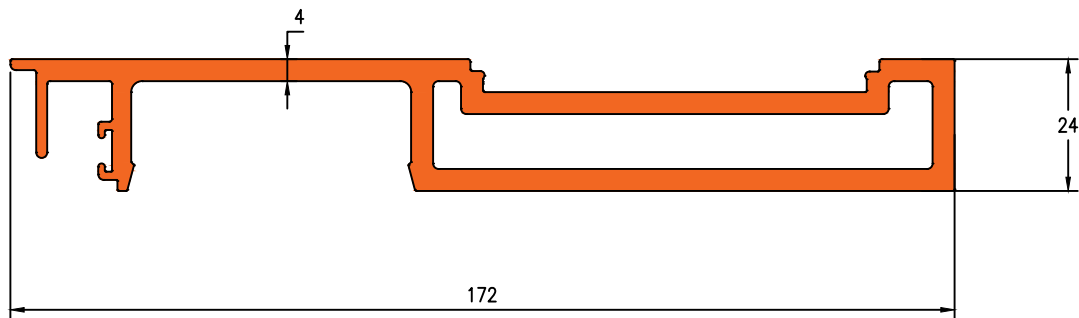



Die No. 16448

1.707 KG/M

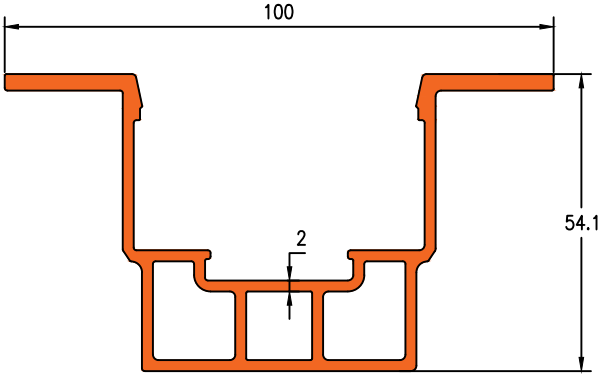



Die No.19992

3.886KG/M

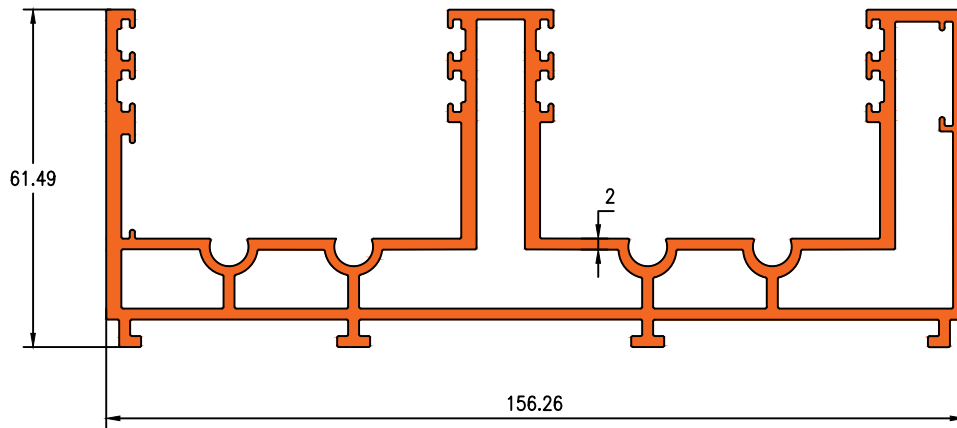

Die No.19989

2.150KG/M

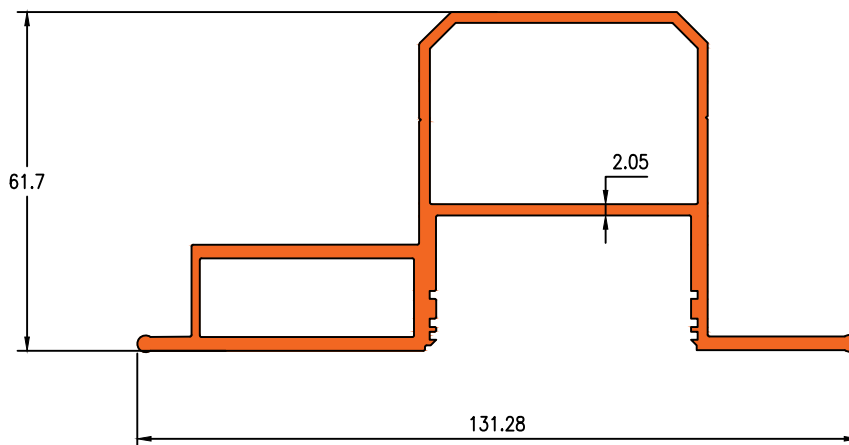

Die No.19952

1.218KG/M

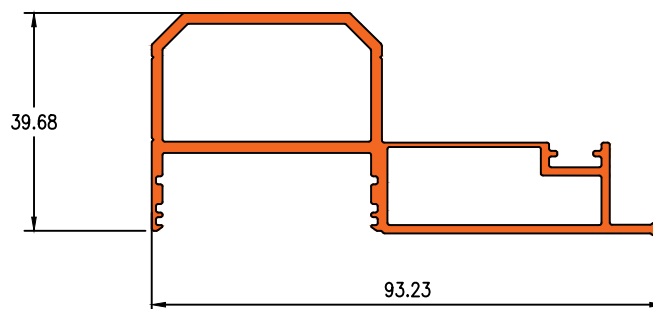



Die No.19953

2.544KG/M

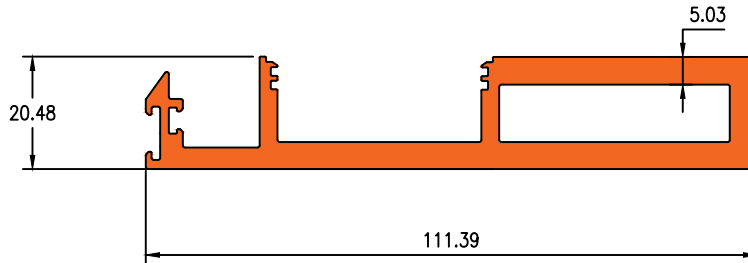

Die No.19957

2.432KG/M

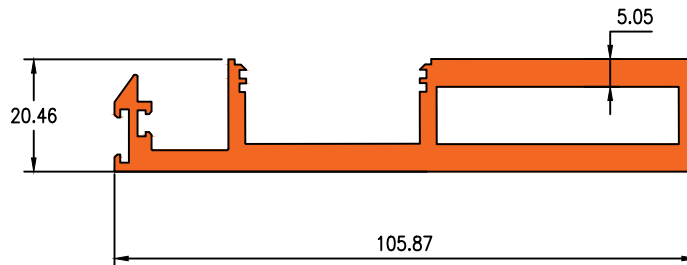

Die No.19990

2.591KG/M

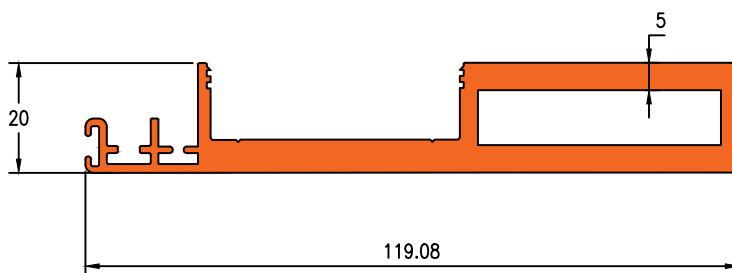



Die No.23023

0.723KG/M

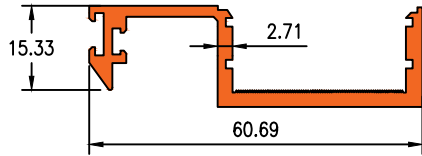

Die No.19499

0.233KG/M

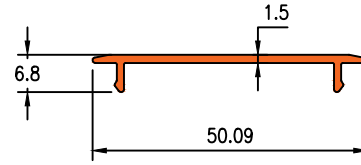

Die No.19725

0.430KG/M

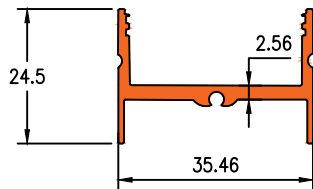

Die No.19991

1.649KG/M

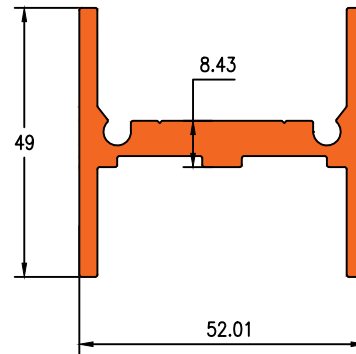

Die No.20062

1.157KG/M

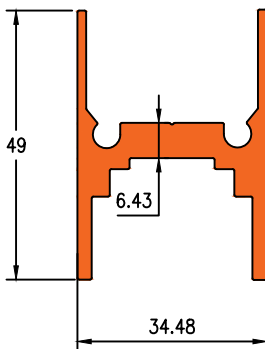



Die No.20096

1.176KG/M

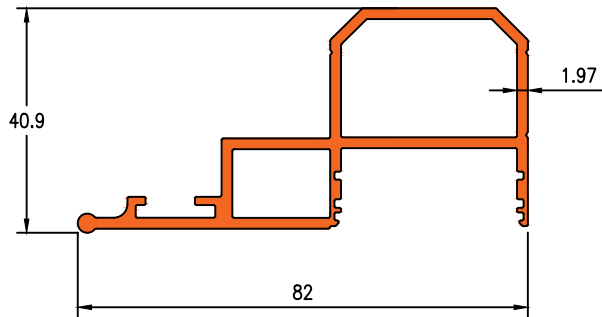

Die No.20097

0.479KG/M

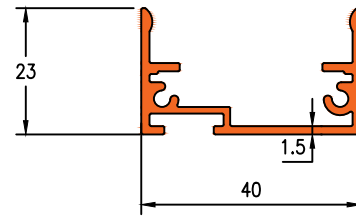

Die No.20098

0.266KG/M

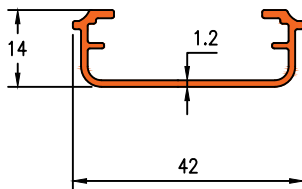

Die No.20099

0.145KG/M

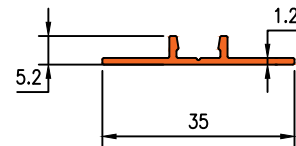



Die No. 16712

3.144KG/M

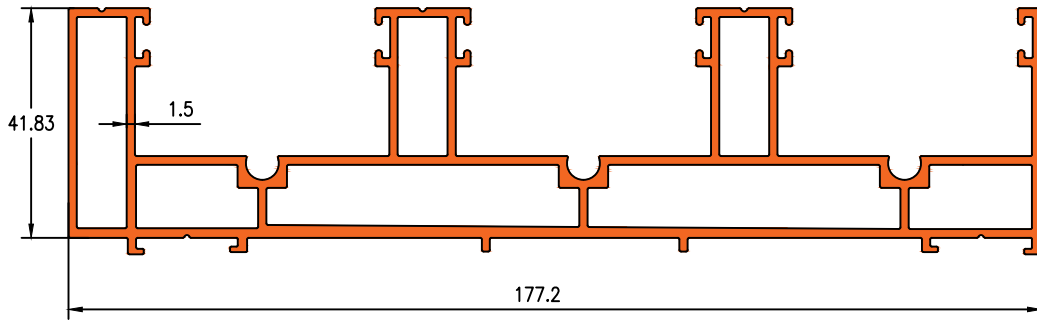

Die No. 16711

2.075KG/M

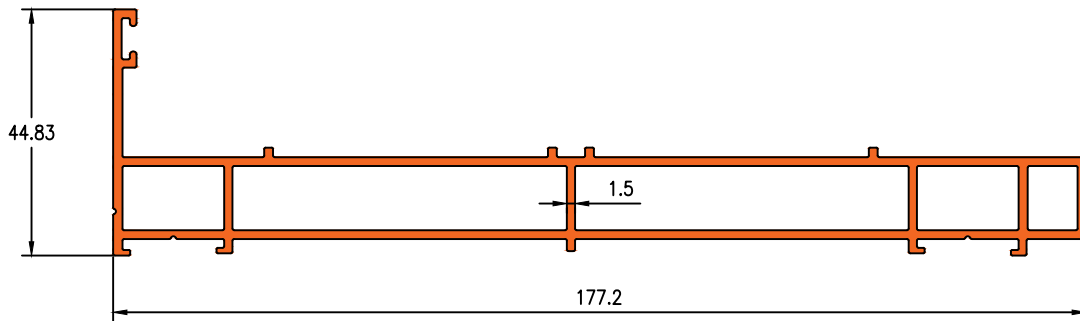



Enq No.1796

1.767 KG/M

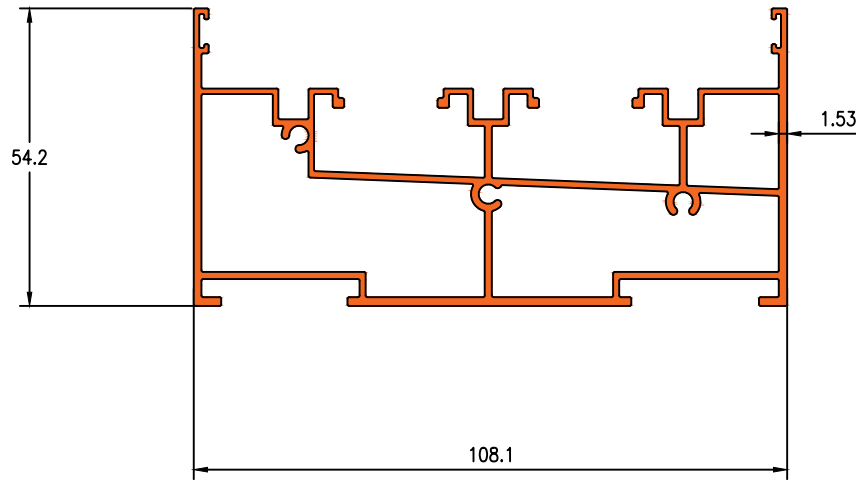

Enq No.1797

0.219 KG/M

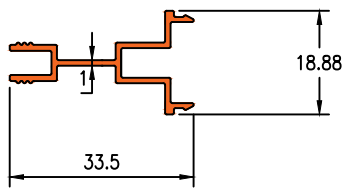

Enq No.1798

0.201 KG/M

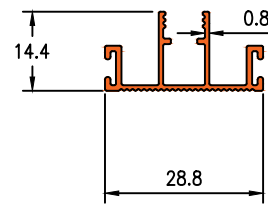

Enq No.1799

0.219 KG/M

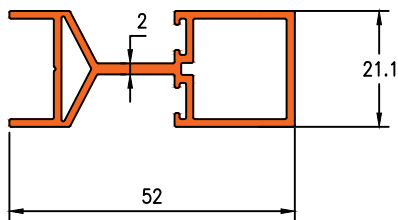

Enq No.1800

0.201 KG/M

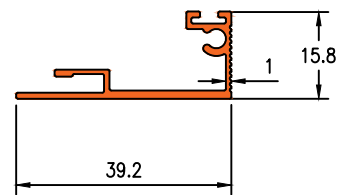



Enq No.1801

1.184 KG/M

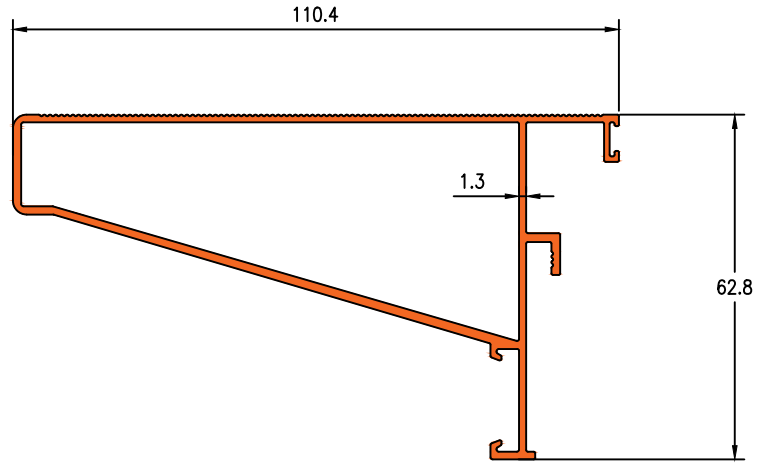

Enq No.1802

0.633 KG/M

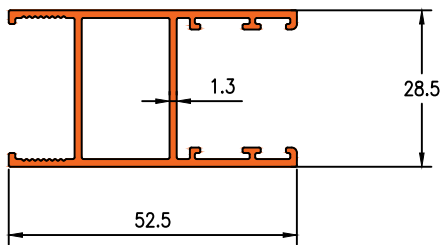

Enq No.1803

0.696 KG/M

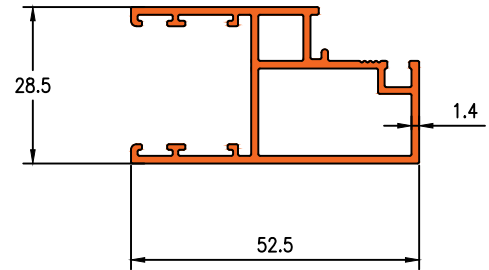

Enq No.1804

1.401 KG/M

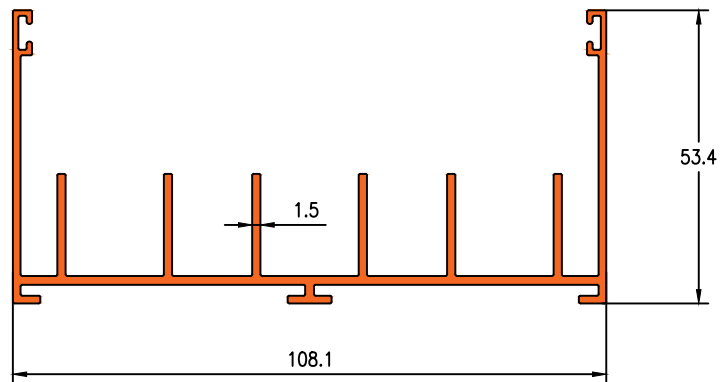



Enq No.1805

0.204 KG/M

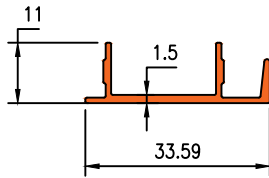

Enq No.1806

0.671KG/M

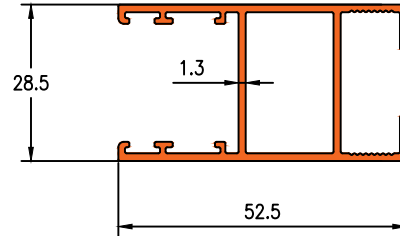

Enq No.1807

0.666KG/M

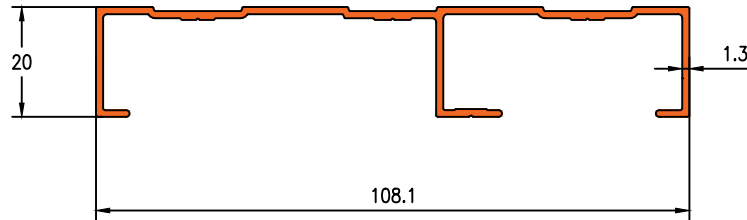

Enq No.1808

0.170 KG/M

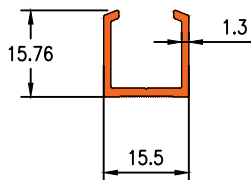

Enq No.1809

1.028 KG/M

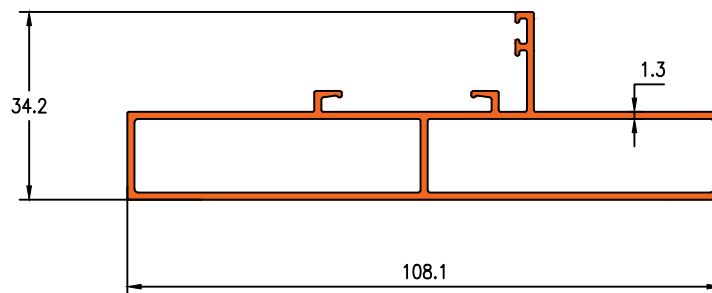



Darshan Extrusions Pvt. Ltd.

Die No.19456

0.594KG/M

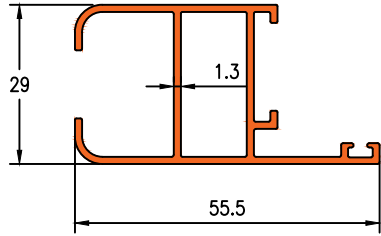

Die No.19457

0.479KG/M

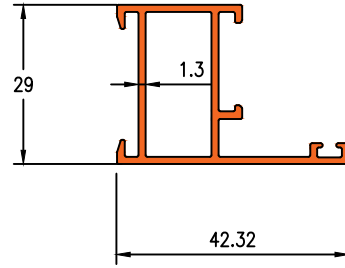

Die No.19727

0.585KG/M

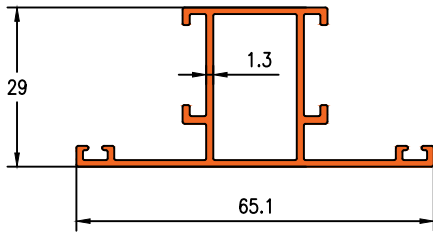

Die No.19728

0.206KG/M

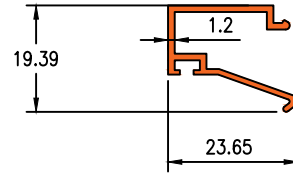



Die No.22097

0.799KG/M

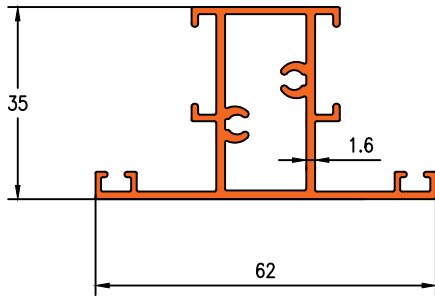

Die No.22098

1.022KG/M

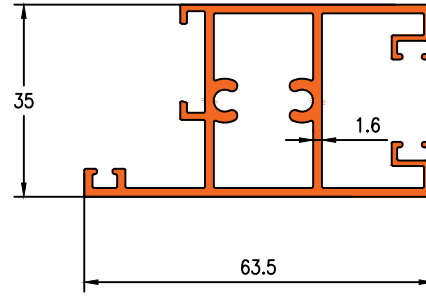

Die No.22099

1.022KG/M

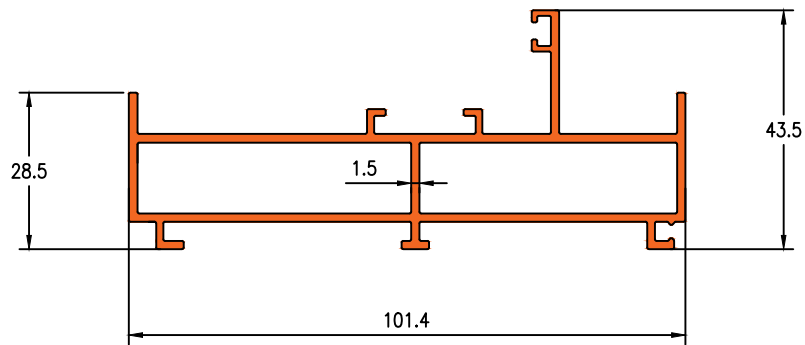

Die No.22096

1.309KG/M

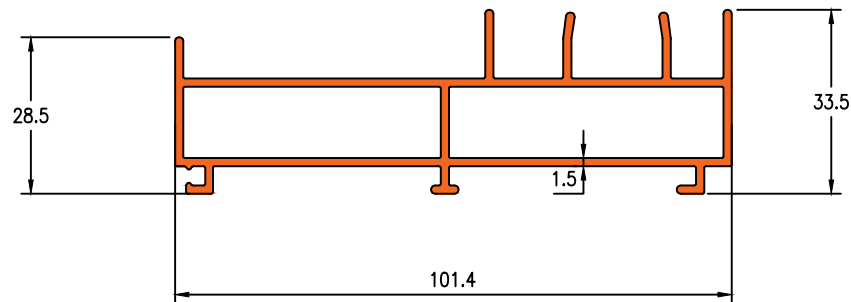

Die No.16649

1.111KG/M

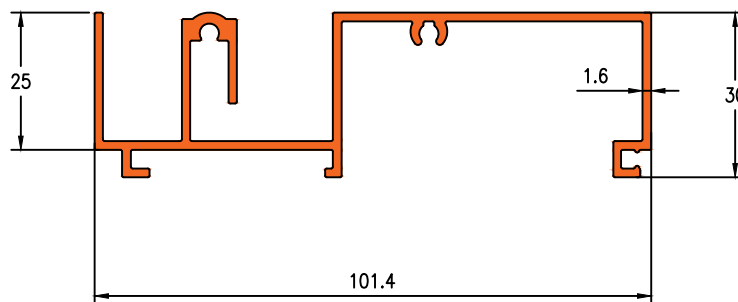



Die No.16646

1.601KG/M

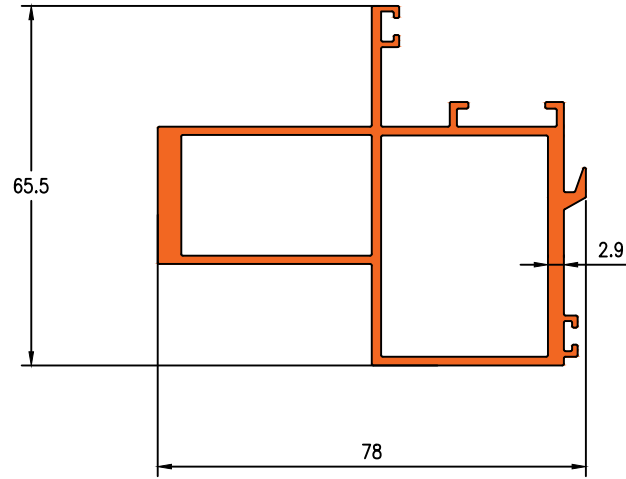

Die No.16647

1.619KG/M

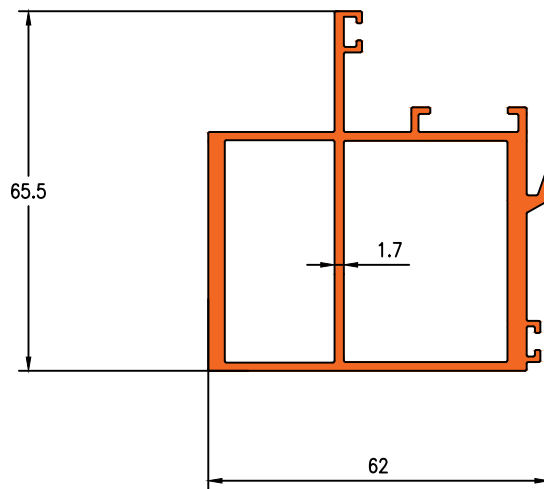



Die No.16650

1.528KG/M

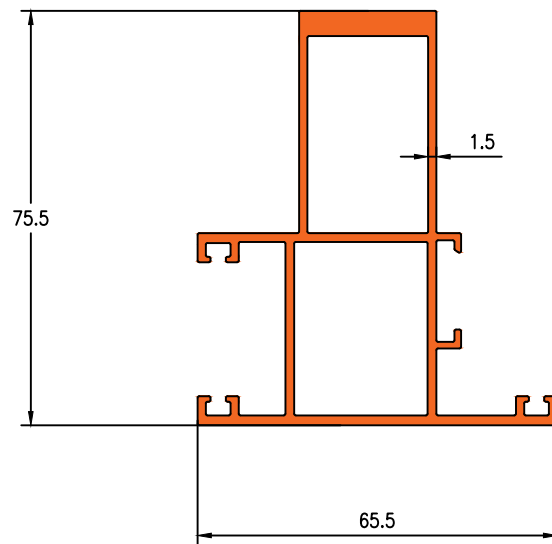

35 MM OPENABLE WINDOW



Darshan Extrusions Pvt. Ltd.

Die No. 4001

0.545KG/M

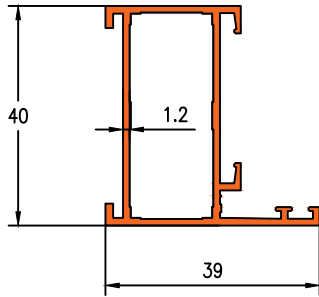

Die No. 4002

0.700KG/M

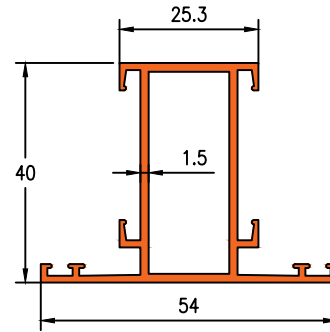

Die No. 4003

0.898KG/M

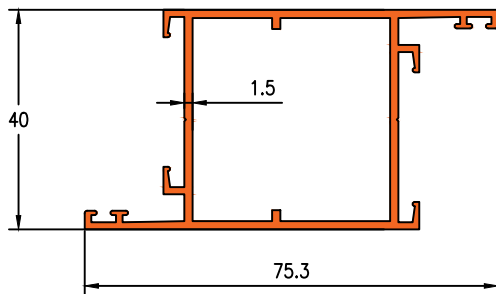

Die No. 4004

0.897KG/M

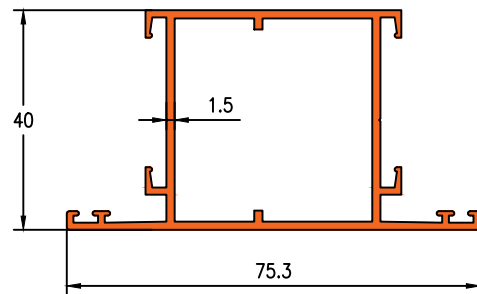

Die No. 4005

1.386KG/M

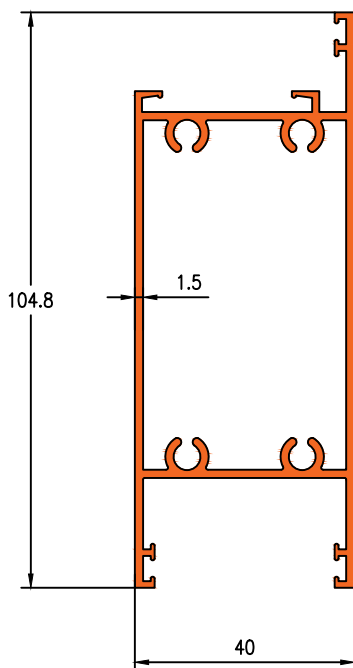

Die No. 16580

0.852KG/M

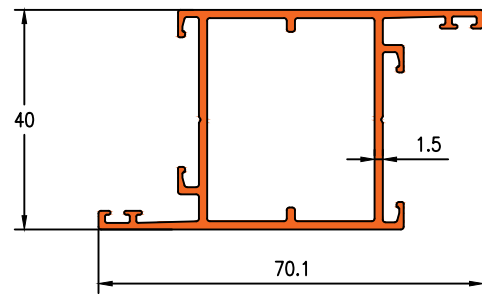

Die No. 16581

0.160KG/M

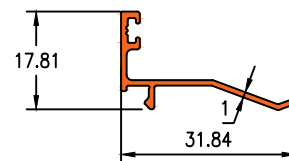

40 MM OPENABLE WINDOW



Darshan Extrusions Pvt. Ltd.

Die No. 4006

0.207KG/M

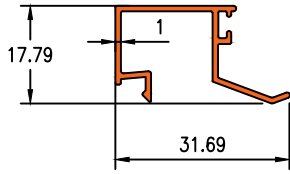

Die No. 4007

0.202KG/M

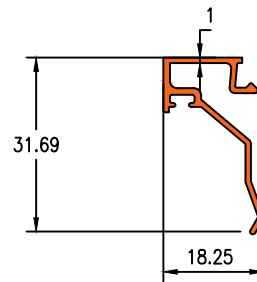

Die No. 16582

1.297KG/M

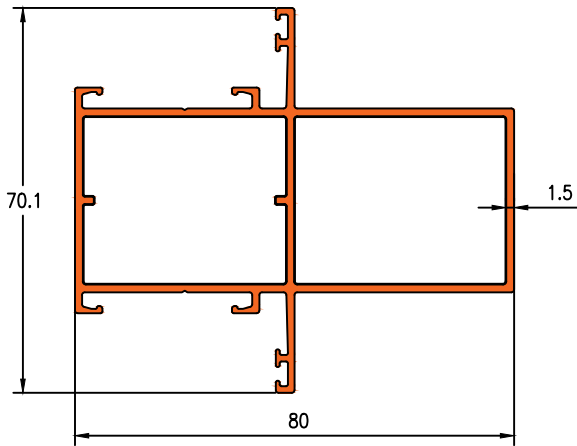

Die No. 16583

0.992KG/M

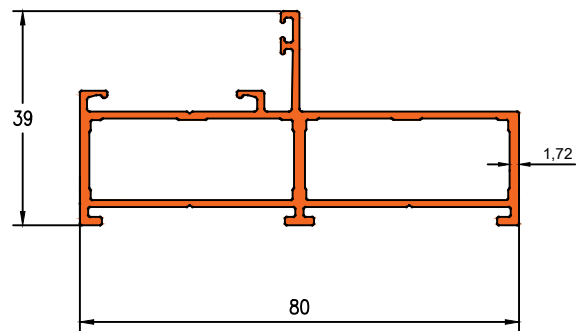

Die No. 4008

0.386KG/M

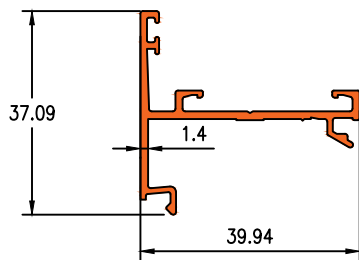

Die No. 4009

0.163KG/M

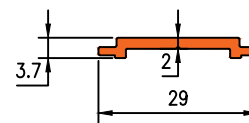

Die No. 4010

0.661KG/M

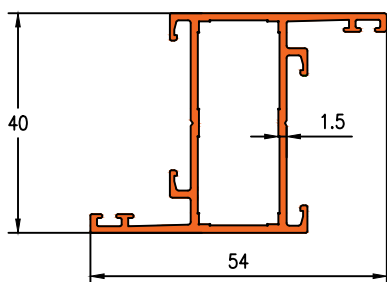

Die No. 4011

0.211KG/M

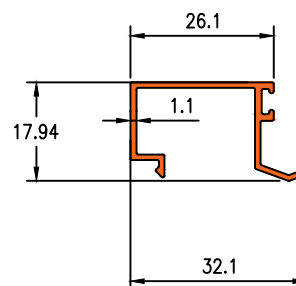

40MM OPENABLE WINDOW



Die No.16048

0.665KG/M

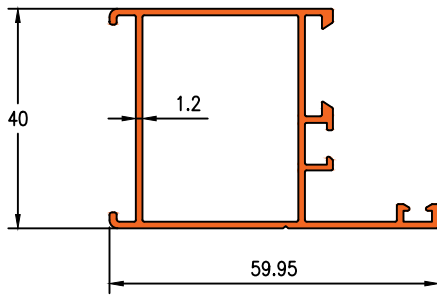

Die No.16047

0.806KG/M

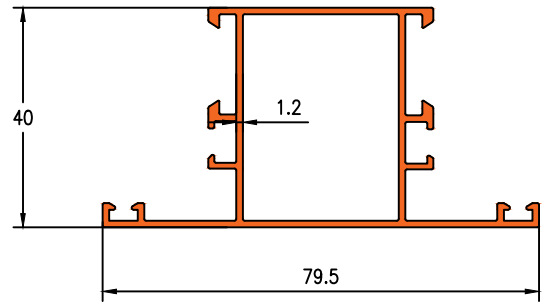

Die No.16055

0.701KG/M

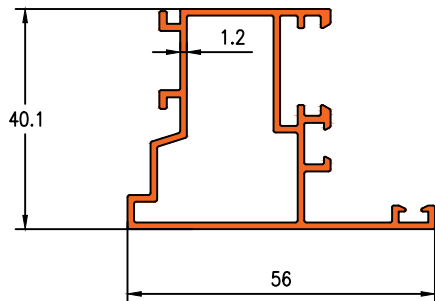

Die No.16126

0.660KG/M

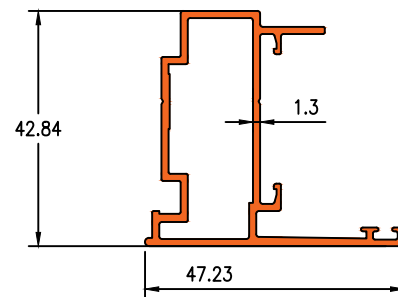



Die No.16021

0.716KG/M

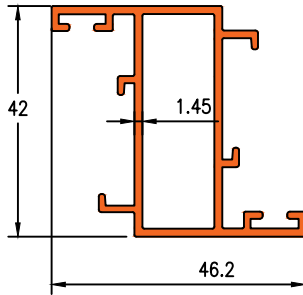

Die No.19458

0.231KG/M

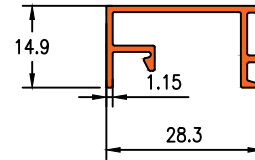

Die No.1383

0.268KG/M

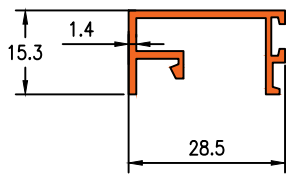

Die No.1382

0.551KG/M

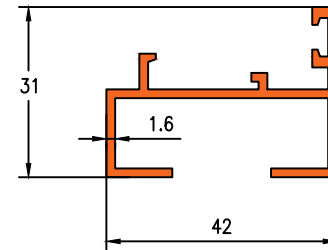

Die No.19713

0.876KG/M

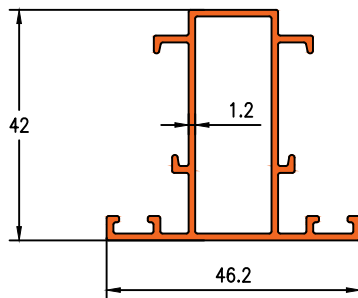

Die No.19717

0.451KG/M

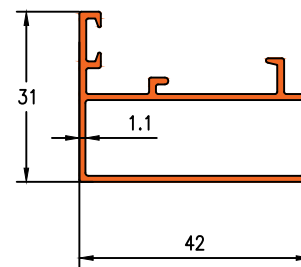



Darshan Extrusions Pvt. Ltd.

Die No. 5103

0.788KG/M

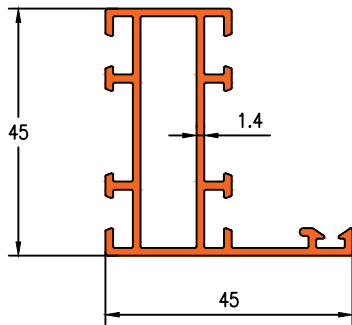

Die No. 5101

0.909KG/M

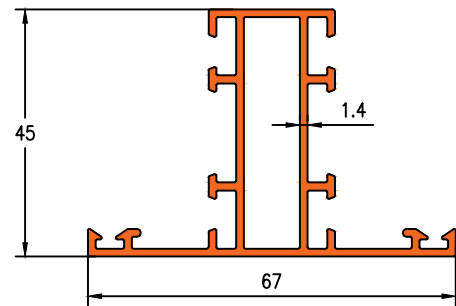

Die No. 5102

0.909KG/M

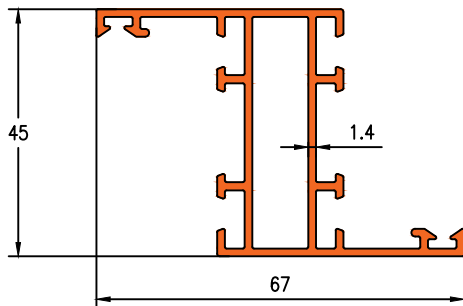

Die No. 5173

0.956KG/M

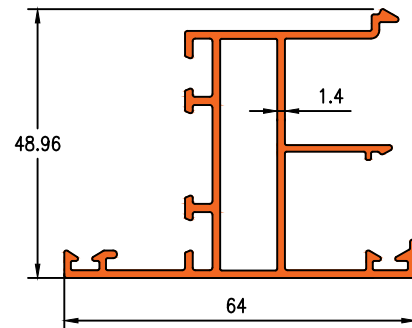

Die No. 5169

0.947KG/M

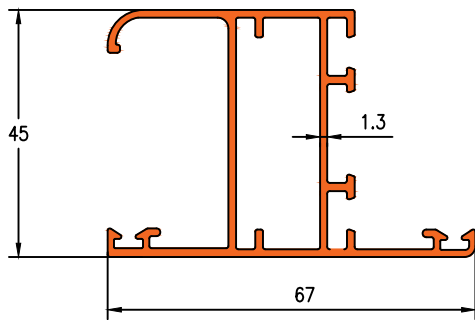

Die No. 5151

1.092KG/M

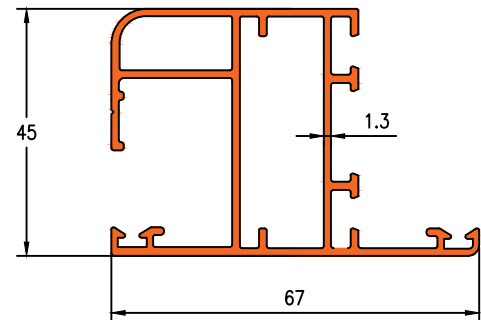

Die No. 5157

0.844KG/M

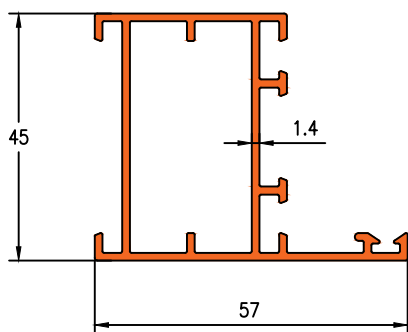

Die No. 5110

0.906KG/M

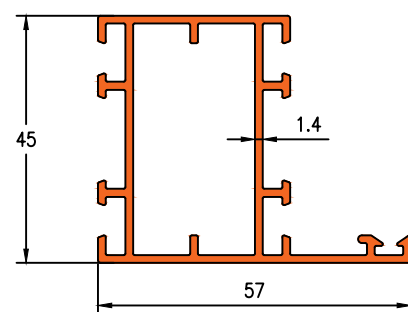



Darshan Extrusions Pvt. Ltd.

Die No.5109

1.137KG/M

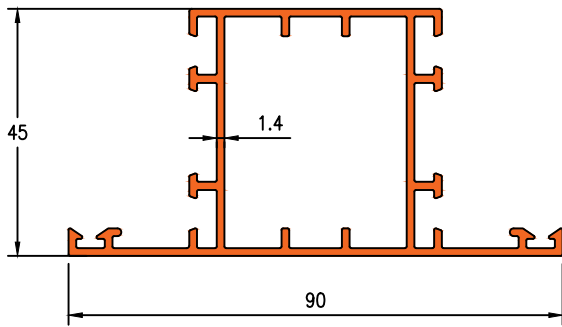

Die No.5108

1.137KG/M

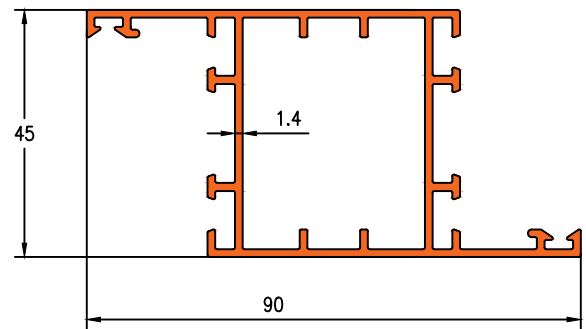

Die No.5367

0.581KG/M

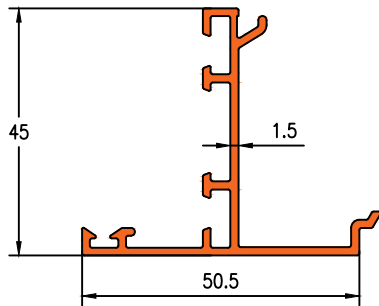

Die No.5170

0.956KG/M

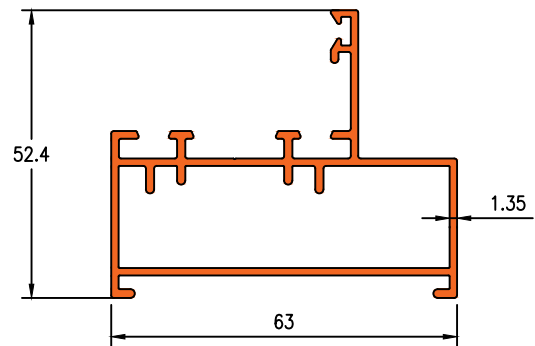

Die No.5137

1.612KG/M

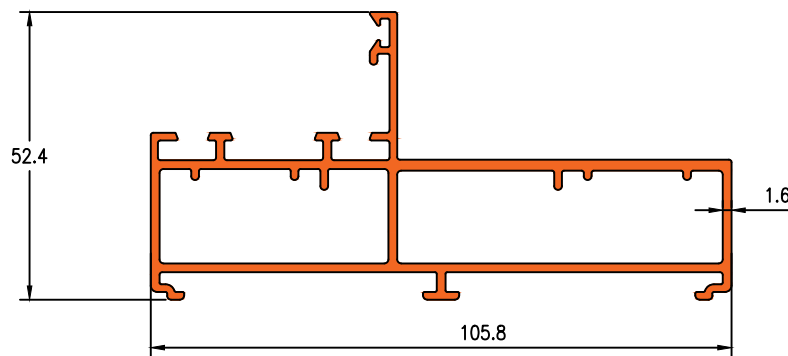

Die No.3820

1.920KG/M

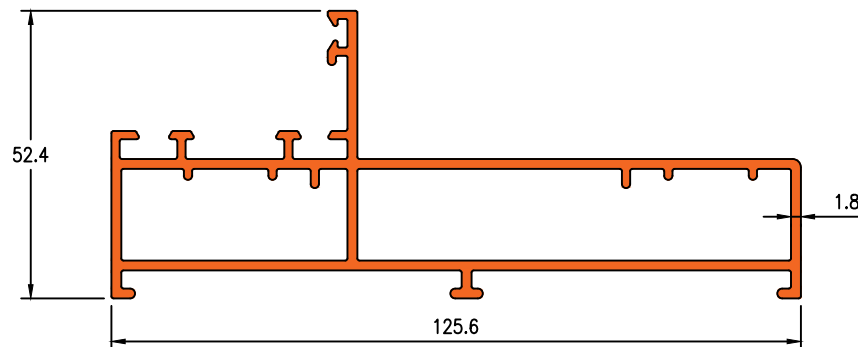



Die No.7870

2.283KG/M

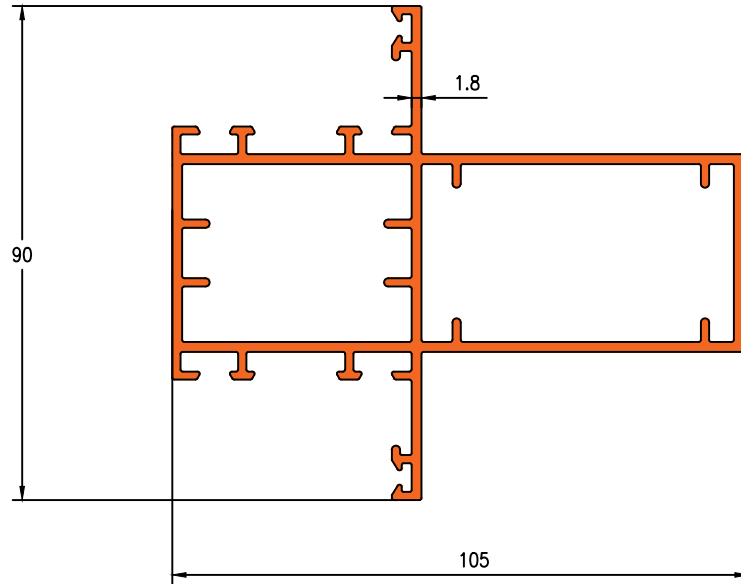

Die No.3819

2.528KG/M

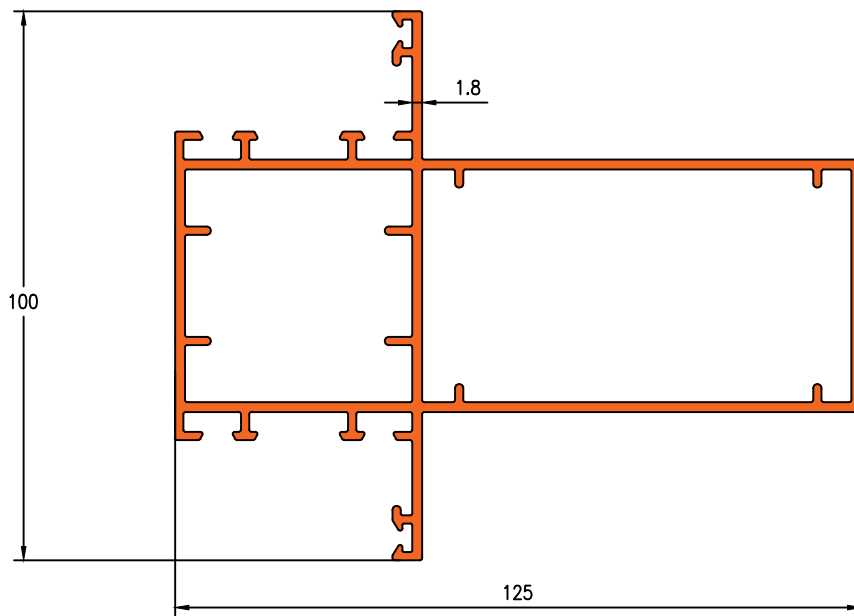



Darshan Extrusions Pvt. Ltd.

Die No.7868

2.271KG/M

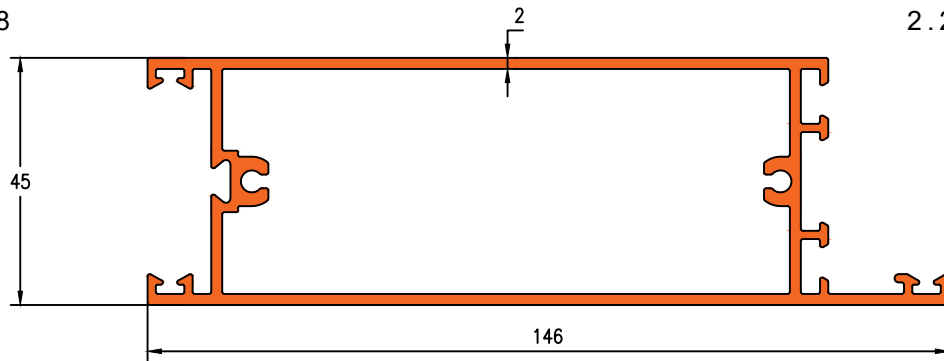

Die No.5185

0.279KG/M

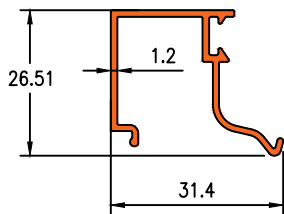

Die No.19643

0.275KG/M

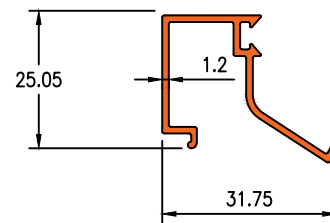

Die No.5150

0.268KG/M

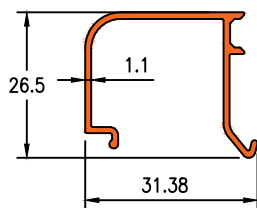

Die No.5149

0.246KG/M

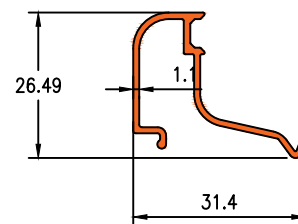

Die No.20113

0.253KG/M

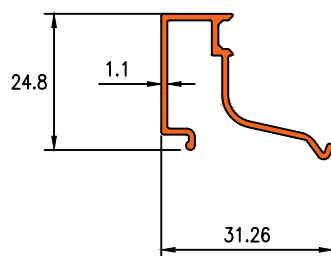



Darshan Extrusions Pvt. Ltd.

Die No.16100

1.033KG/M

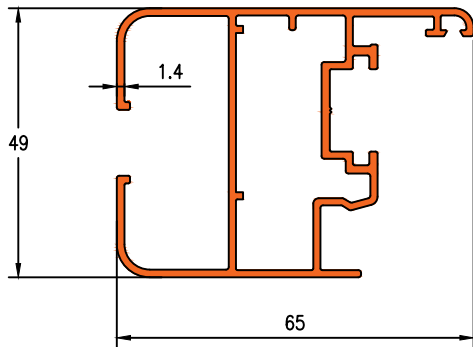

Die No.16101

1.003KG/M

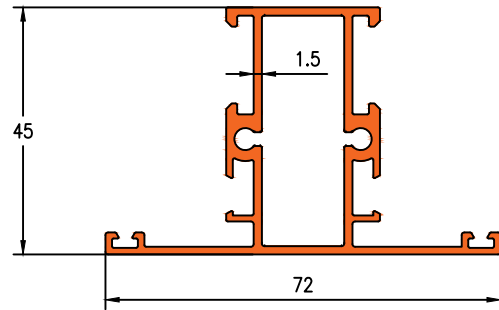

Die No.16102

0.612KG/M

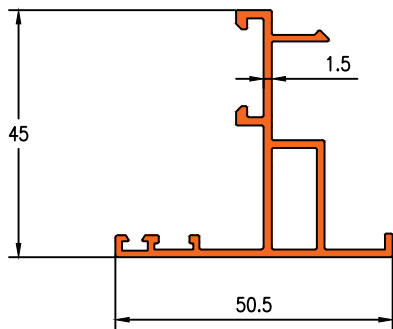

Die No.2854

0.578KG/M

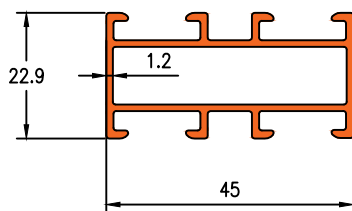

Die No.2853

0.866KG/M

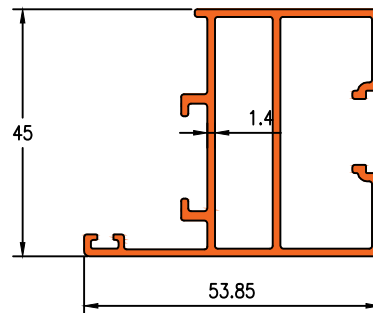

Die No.2856

0.203KG/M

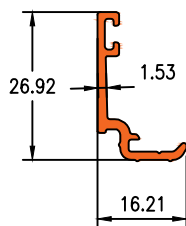

Die No.16099

0.208KG/M

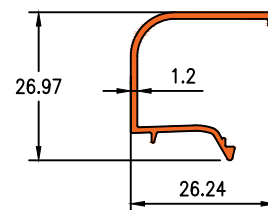



Die No.16096

0.434KG/M

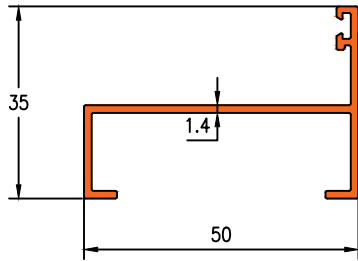

Die No.16097

0.781KG/M

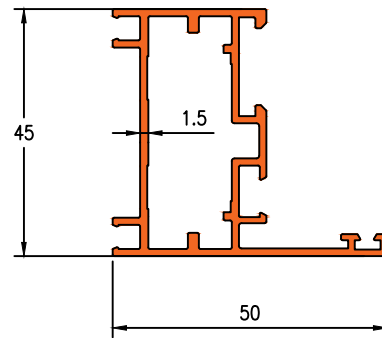

Die No.16098

0.260KG/M

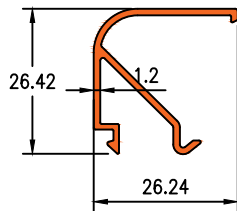

Die No.2855

0.288KG/M

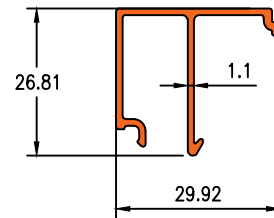

Die No.2852

0.590KG/M

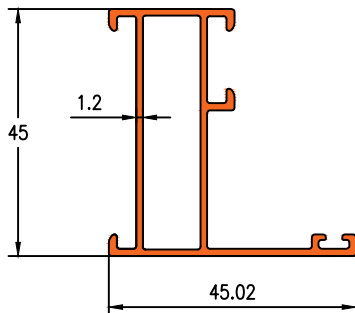



Darshan Extrusions Pvt. Ltd.

Die No.16056

0.962KG/M

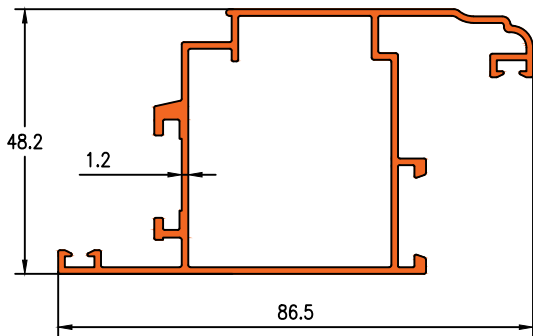

Die No.16058

0.702KG/M

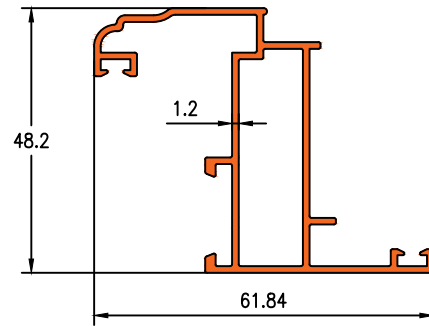

Die No.16057

0.958KG/M

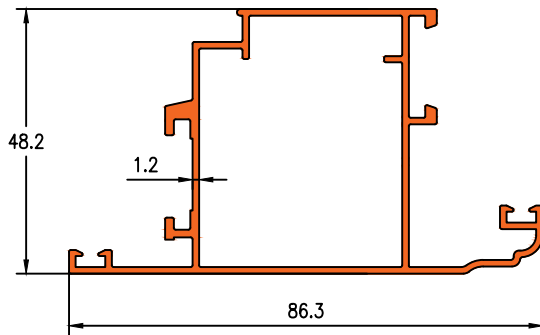

Die No.16059

0.768KG/M

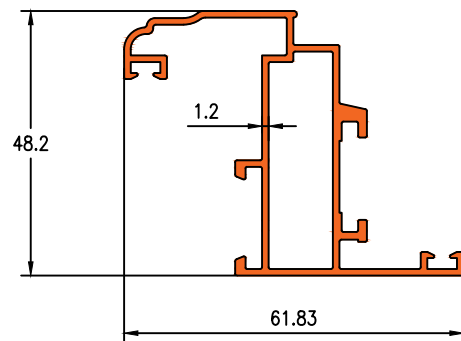

Die No.16061

0.778KG/M

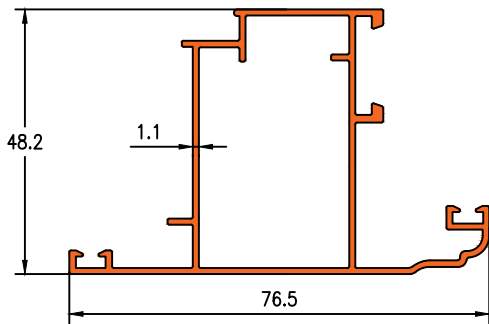

Die No.16060

0.792KG/M

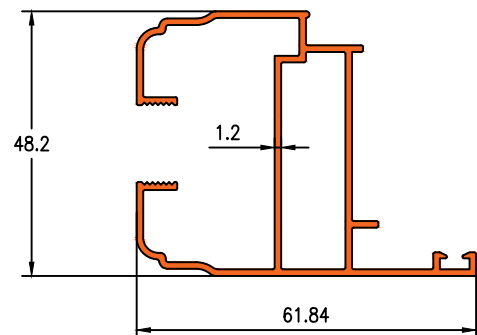



Darshan Extrusions Pvt. Ltd.

Die No.16256

0.132KG/M

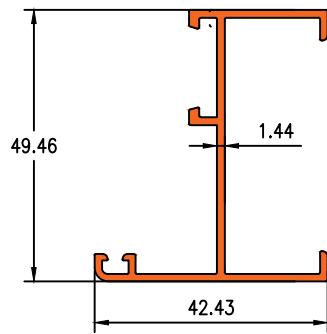

Die No.16254

0.890KG/M

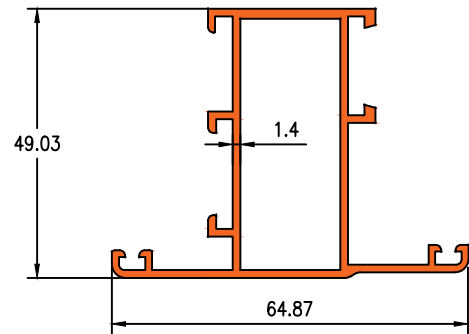

Die No.16255

0.962KG/M

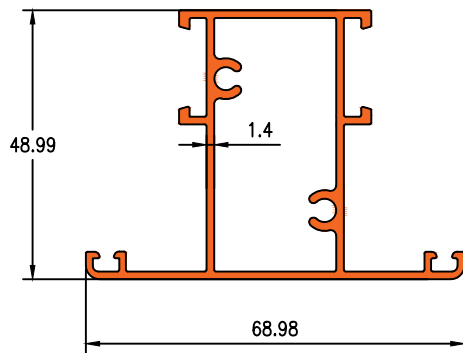

Die No.16257

0.049 KG/M

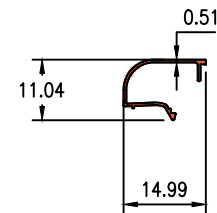

Die No.16258

0.221KG/M

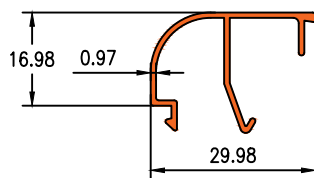

Die No.19357

0.209KG/M

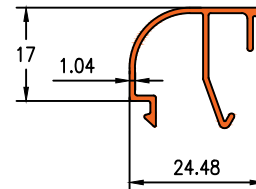

Die No.19358

0.180KG/M

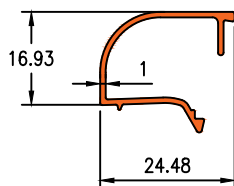



Darshan Extrusions Pvt. Ltd.

Die No. 5001

0.807KG/M

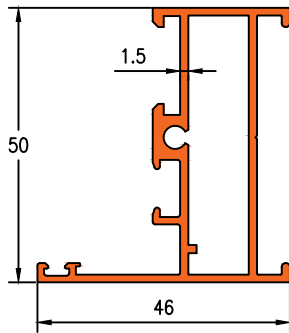

Die No. 5002

0.999KG/M

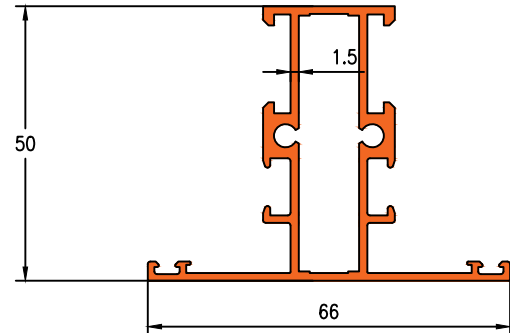

Die No. 5003

1.138KG/M

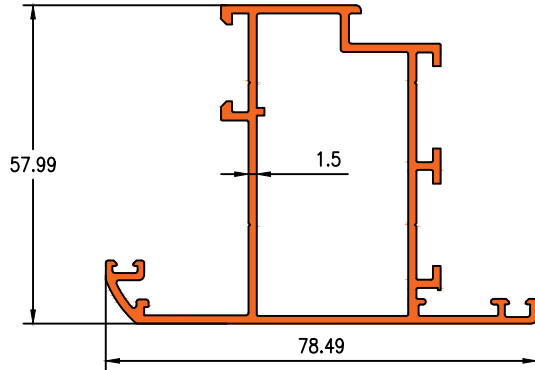

Die No. 5004

0.954KG/M

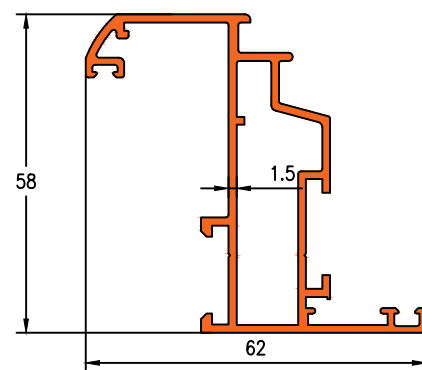

Die No. 5005

1.206KG/M

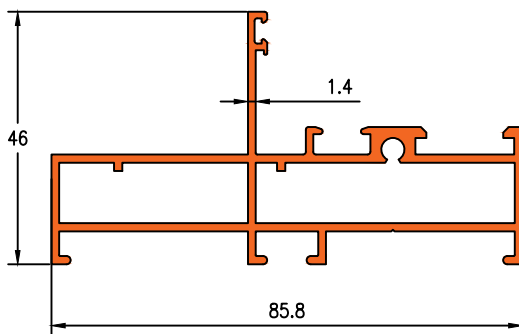

Die No. 5006

0.806KG/M

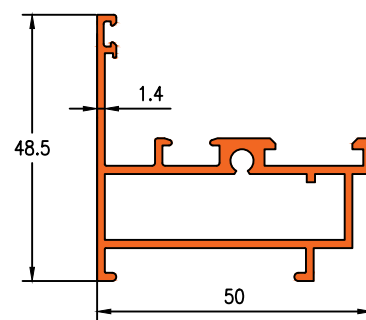

Die No. 5007

1.080KG/M

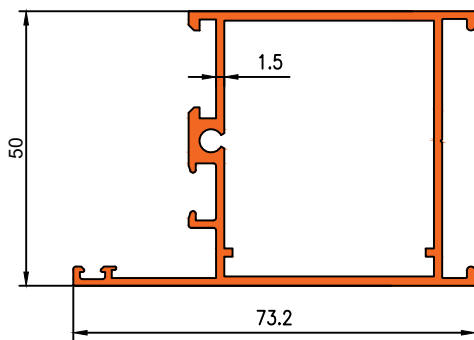

Die No. 5008

1.260KG/M

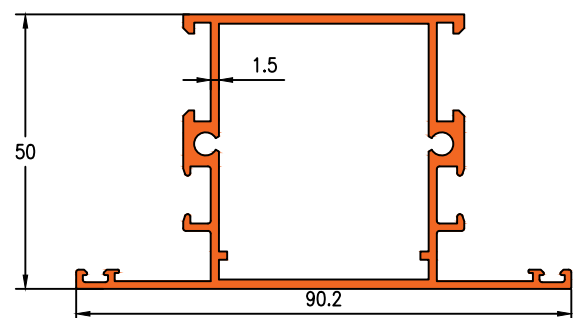

50 MM OPENABLE WINDOW



Darshan Extrusions Pvt. Ltd.

Die No. 5009 1.291KG/M

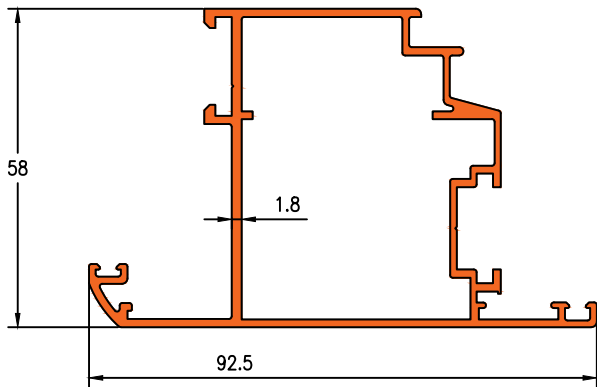

Die No. 5010 0.965KG/M

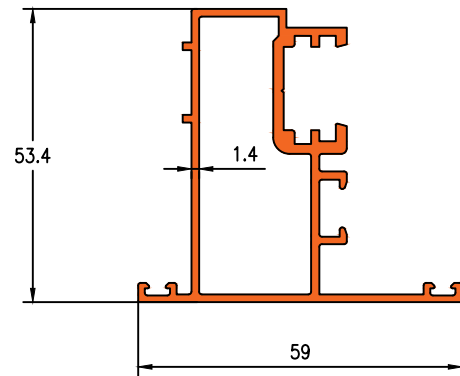

Die No. 5011 2.135KG/M



Die No. 5012 2.291KG/M

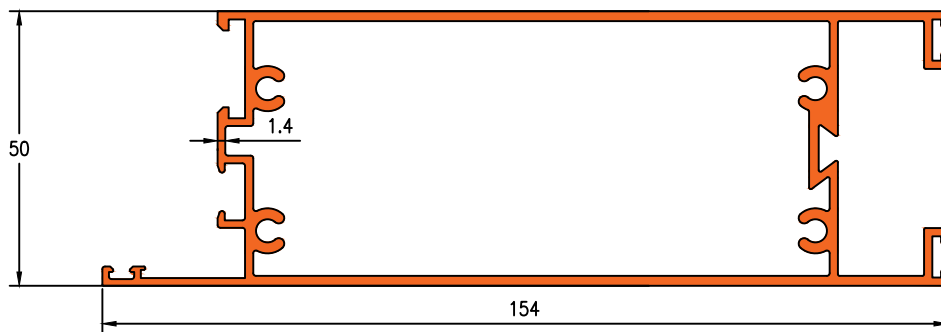

Die No. 16558 1.404KG/M

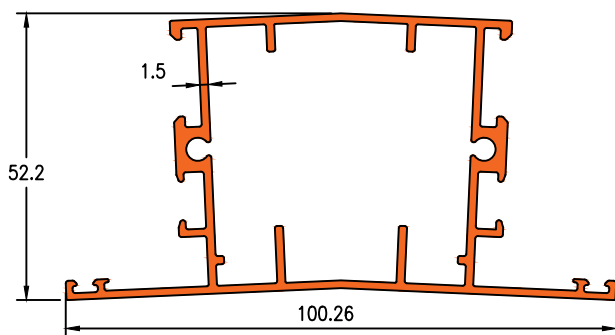

Die No. 5013 0.313KG/M

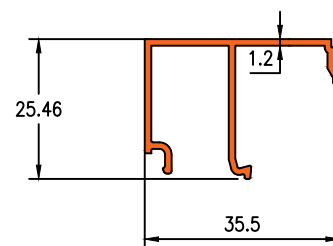

50 MM OPENABLE WINDOW



Darshan Extrusions Pvt. Ltd.

Die No. 5014

0.230KG/M

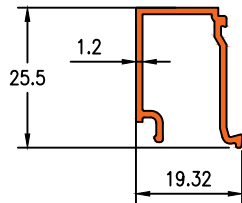

Die No. 5015

0.289KG/M

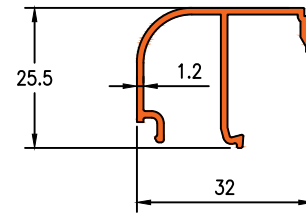

Die No. 5016

0.217KG/M

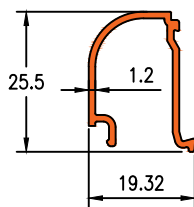

Die No. 5017

0.501KG/M

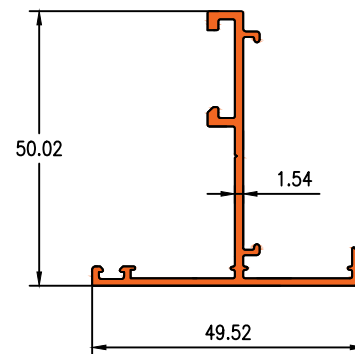

Die No. 5018

0.265KG/M

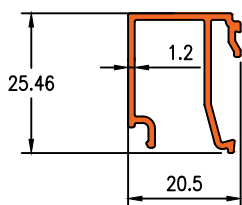

Die No. 16103

0.911KG/M

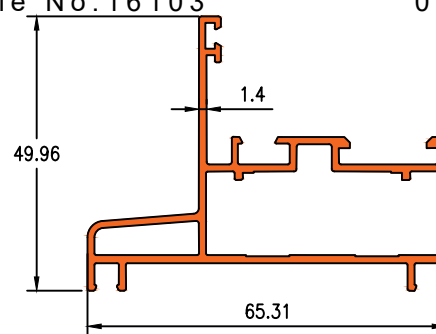

Die No. 5019

0.290KG/M

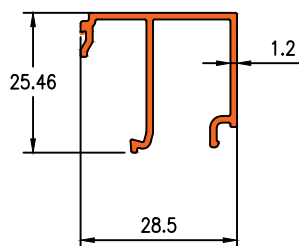

Die No. 16125

0.951KG/M

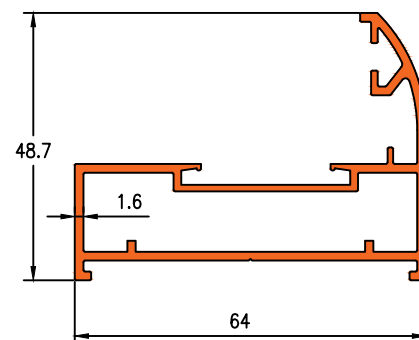



Die No.20045

0.869KG/M

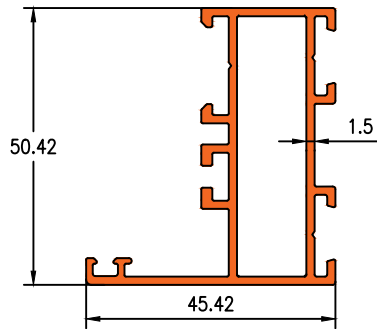

Die No.20047

1.171KG/M

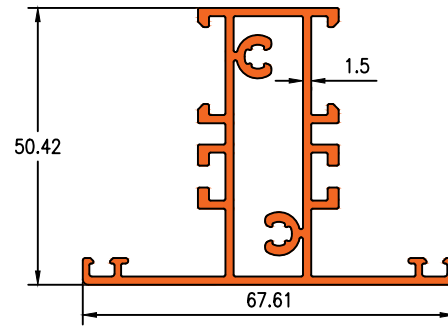

Die No.20049

0.091KG/M

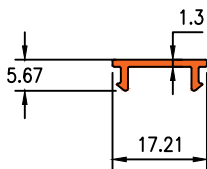

Die No.20050

0.144KG/M

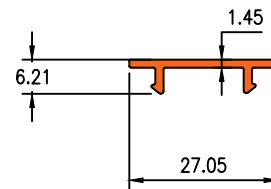

Die No.21023

0.192KG/M

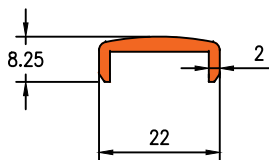

Die No.21024

0.521KG/M

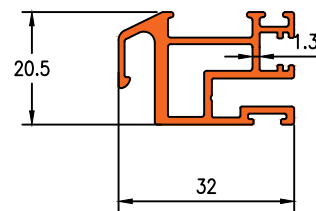

Die No.22018

0.492KG/M

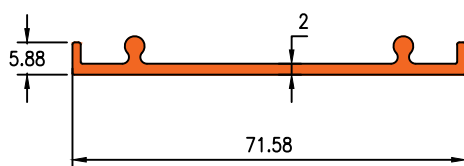

Die No.19674

0.218KG/M

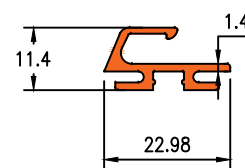



Die No.21021

1.172KG/M

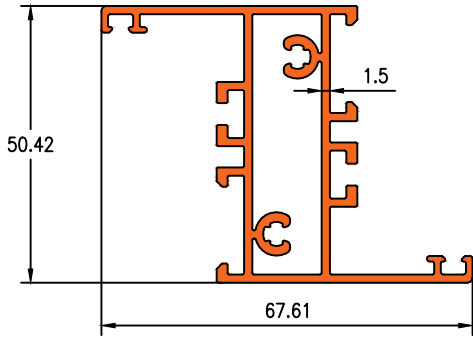

Die No.19974

1.166KG/M

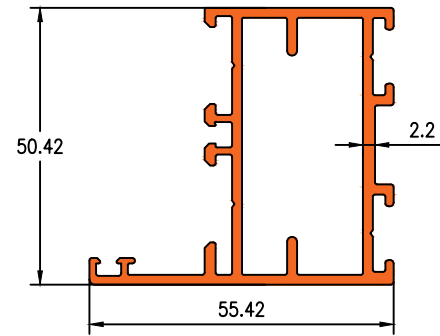

Die No.20046

1.435KG/M

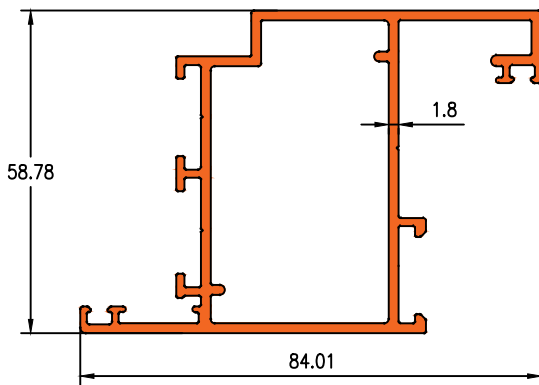

Die No.19973

1.649KG/M

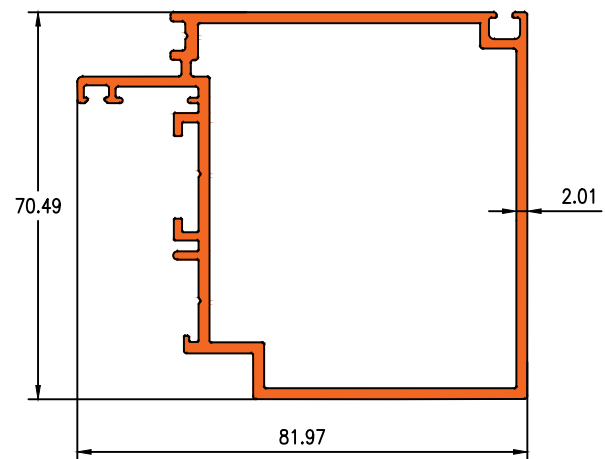

Die No.19664

1.354KG/M

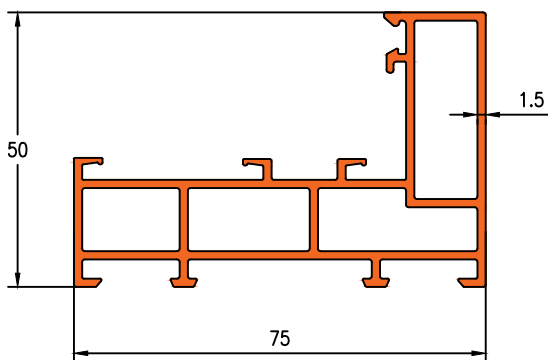

Die No.19665

0.395KG/M

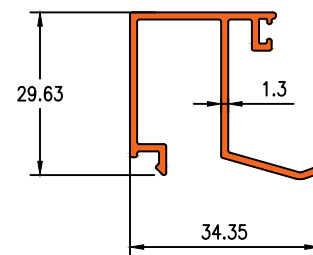



Die No.19642

1.001KG/M

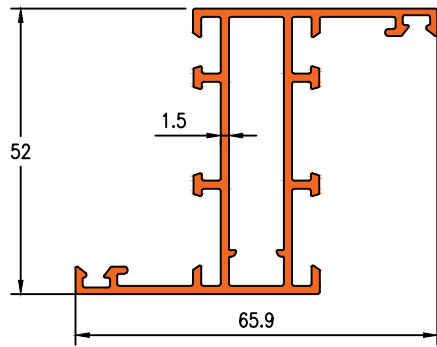

Die No.19641

0.882KG/M

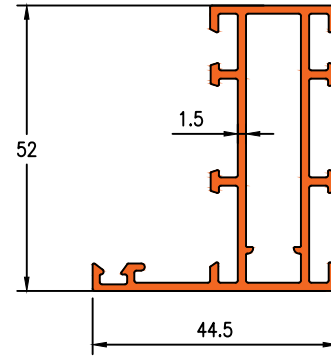

Die No.19649

0.944KG/M

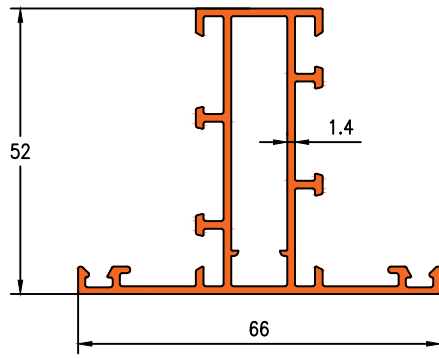

Die No.19644

0.311KG/M

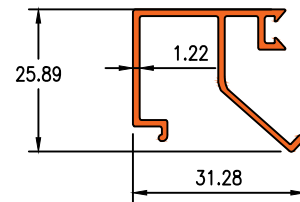

Die No.19643

0.275KG/M

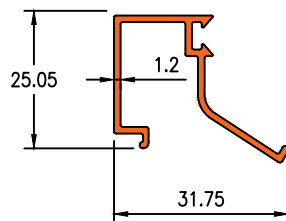



Darshan Extrusions Pvt. Ltd.

Die No.28155

0.837KG/M

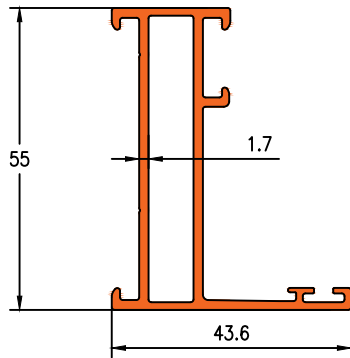

Die No.28157

1.093KG/M

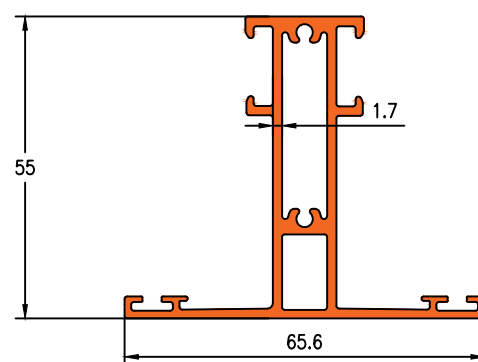

Die No.28159

0.532KG/M

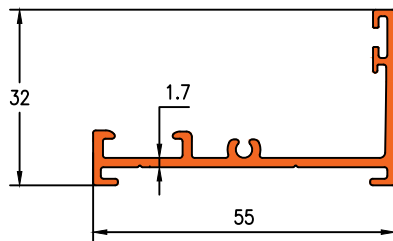

Die No.28161

1.108KG/M

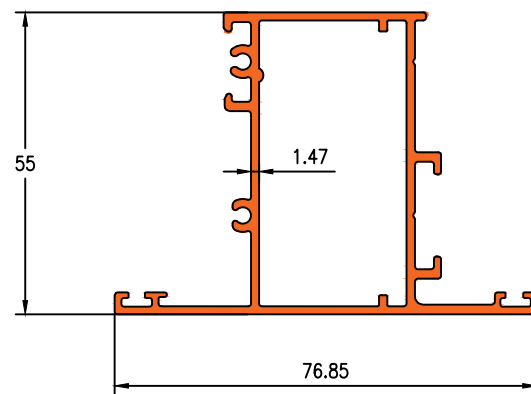

Die No.23164

0.275KG/M

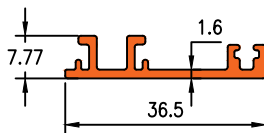

Die No.23162

1.427KG/M

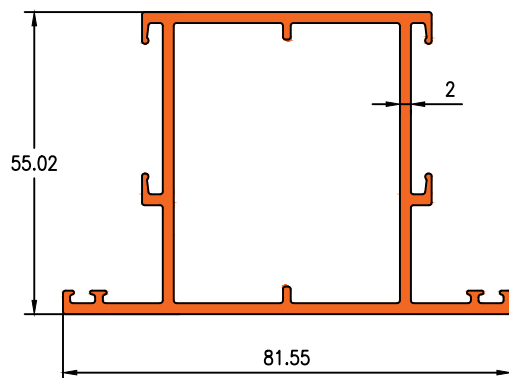

Die No.23163

1.348KG/M

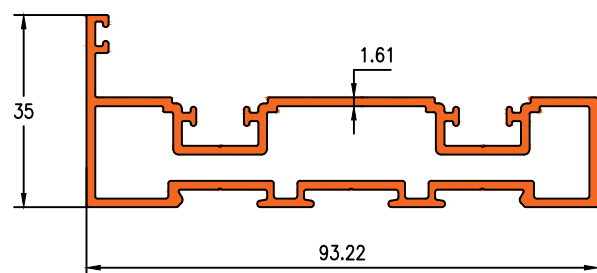

55 MM OPENABLE WINDOW



Die No.16233

1.443KG/M

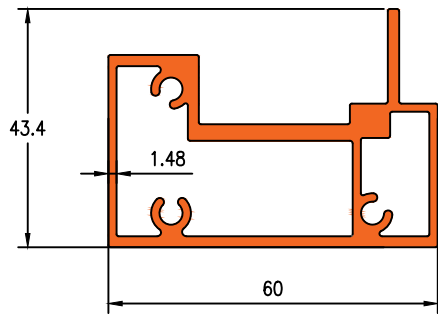

Die No.16234

1.006KG/M

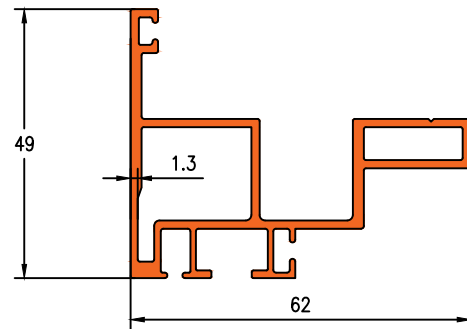

Die No.16235

1.020KG/M

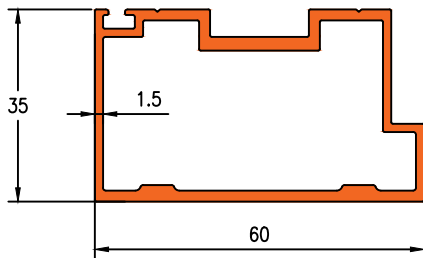

Die No.16236

1.036KG/M

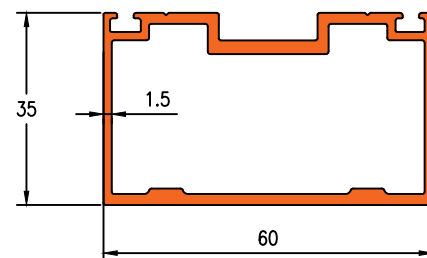

Die No.16237

1.254KG/M

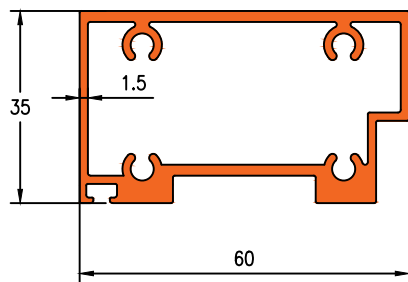

Die No.16240

1.886KG/M

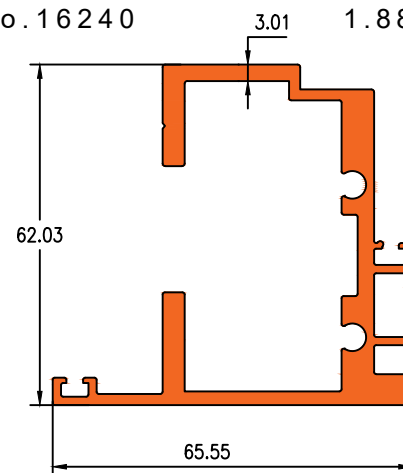



Die No. 1439

1.057KG/M

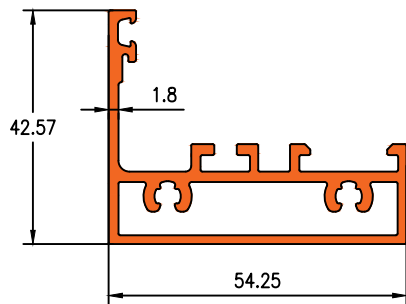

Die No. 1438

1.145KG/M

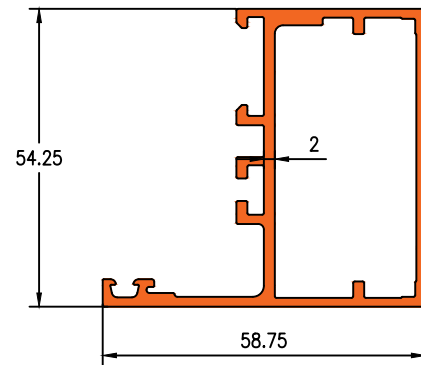

Die No. 1441

2.011KG/M

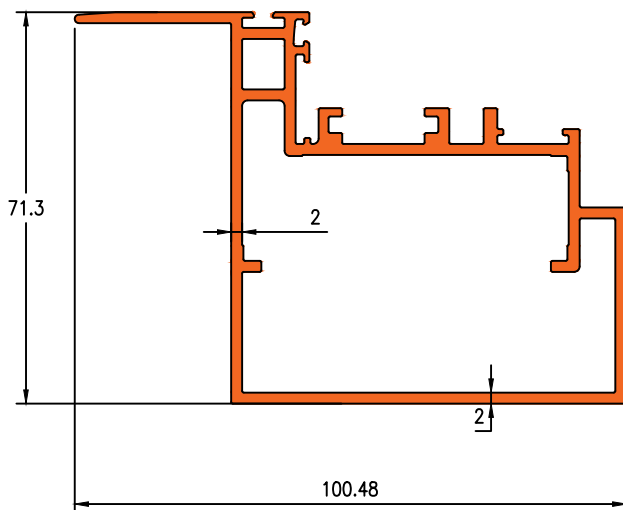

Die No. 1442

2.021KG/M

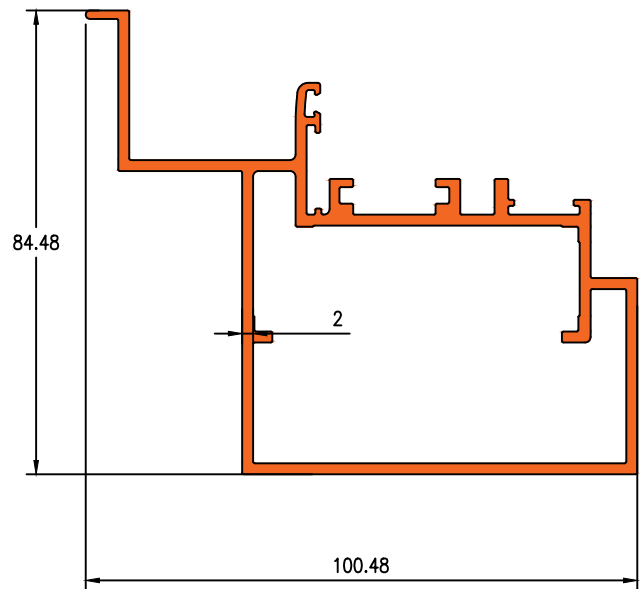

Die No. 16239

1.065KG/M

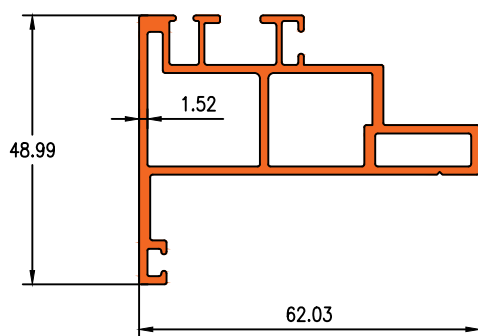

Die No. 19974

1.166KG/M

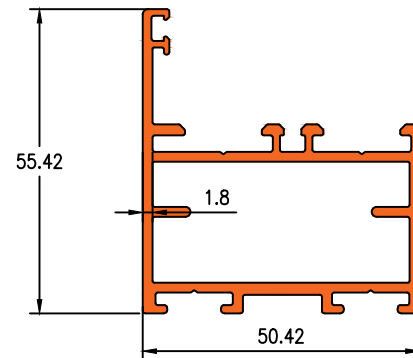



Die No. 1440

1.528KG/M

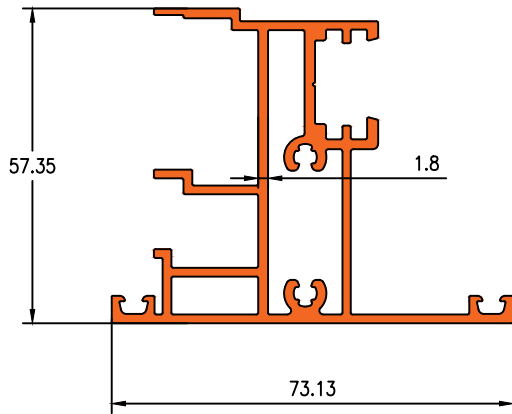

Die No. 1403

0.497KG/M

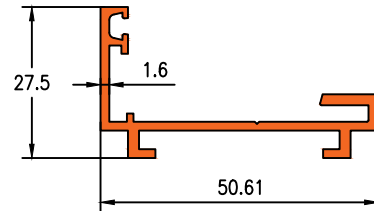

Die No. 1407

1.395KG/M

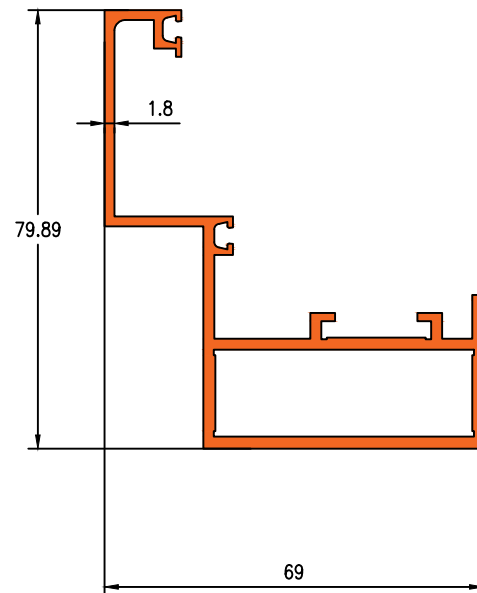

Die No. 19973

1.649KG/M

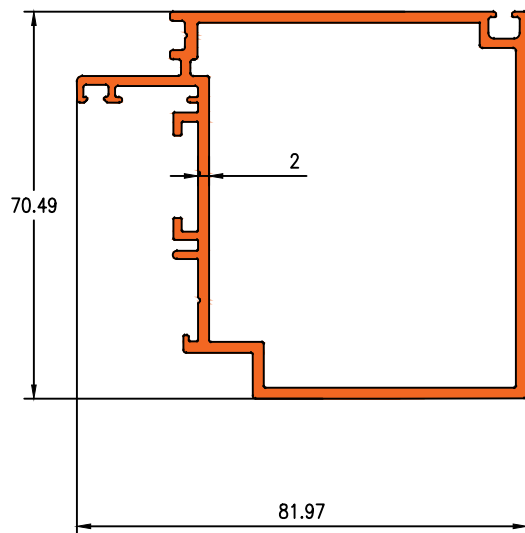



Die No.28185

0.344KG/M

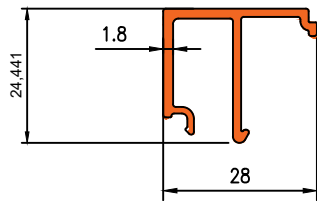

Die No.28184

0.376KG/M

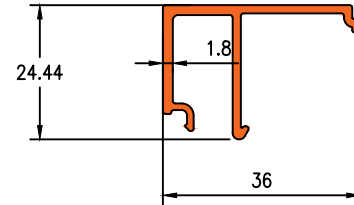

Die No.16086

0.710KG/M

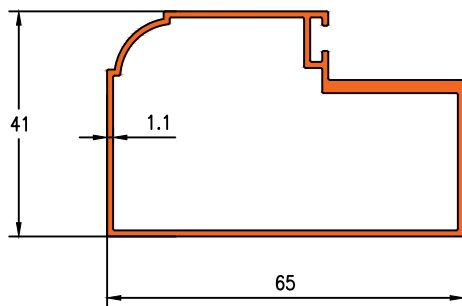

Die No.16185

0.623KG/M

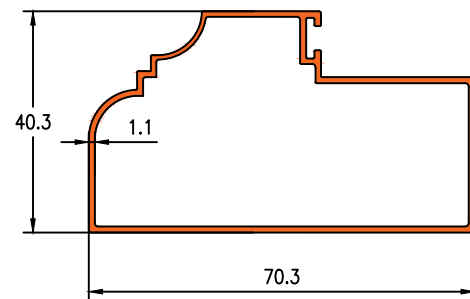

Die No.7108

0.617KG/M

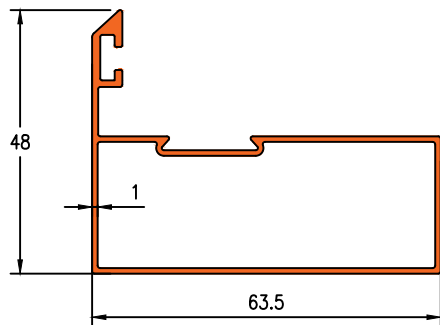

Die No.28195

0.311KG/M

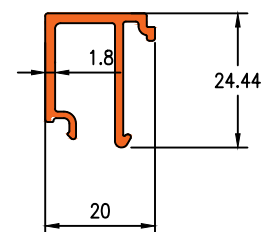



Die No.16021

0.716KG/M

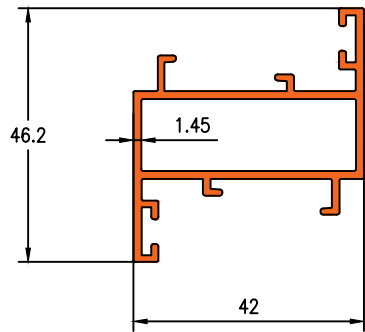

Die No.16150

0.963KG/M

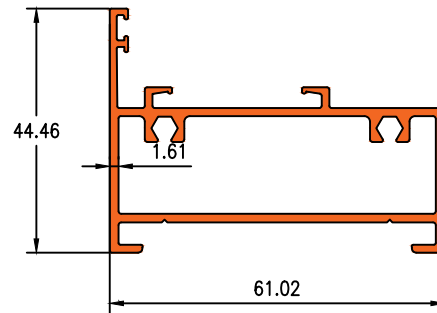

Die No.10140

0.769KG/M

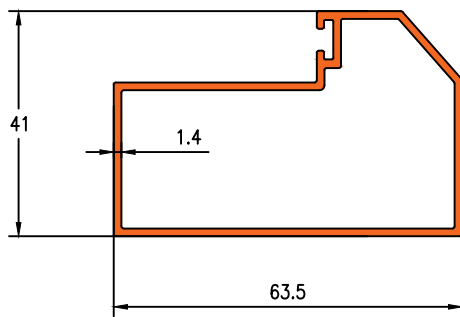

Die No.16179

0.999KG/M

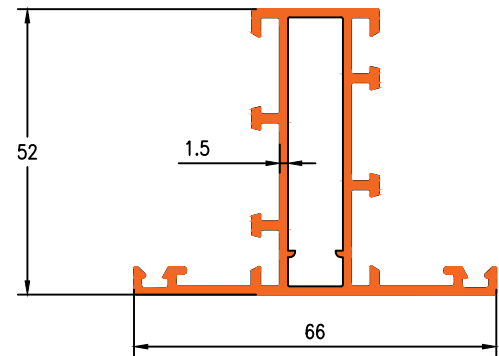

Die No.1262

1.193KG/M

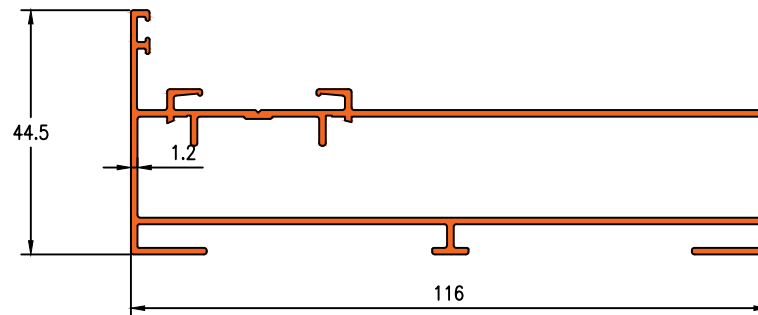



Die No. 1462

1.060KG/M

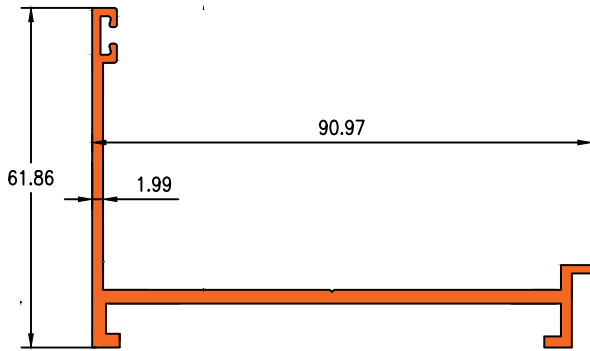

Die No. 1367

1.073KG/M

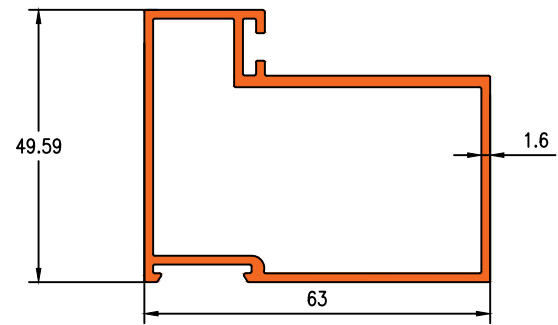

Die No. 16152

1.218KG/M

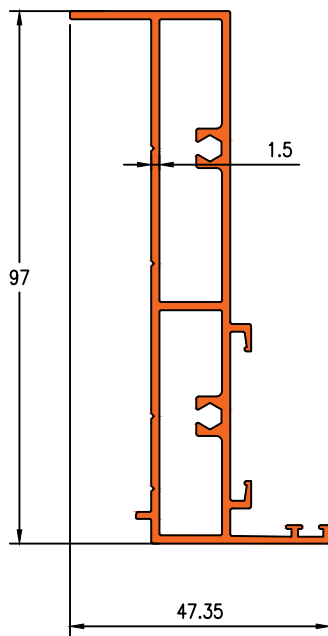

Die No. 16153

0.910KG/M

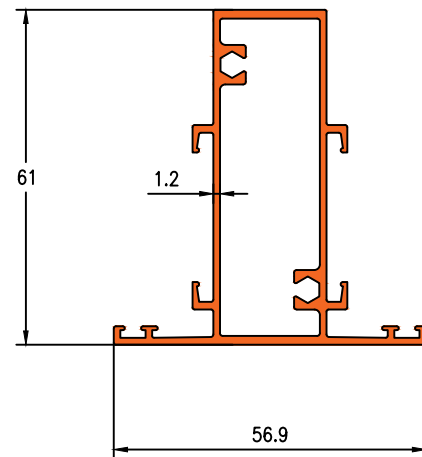

Die No. 16154

1.303KG/M

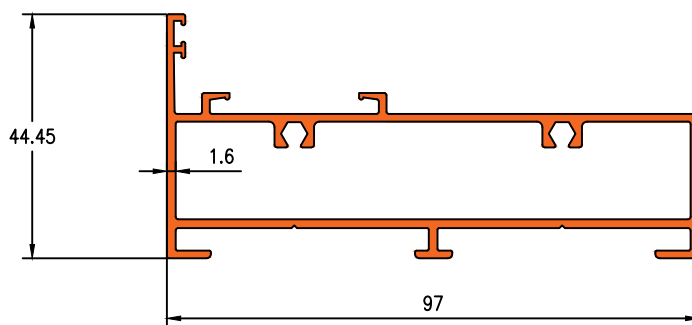



Die No.19415

0.299KG/M

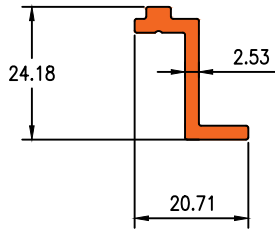

Die No.19416

0.757KG/M

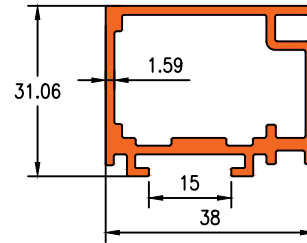

Die No.19430

0.908KG/M

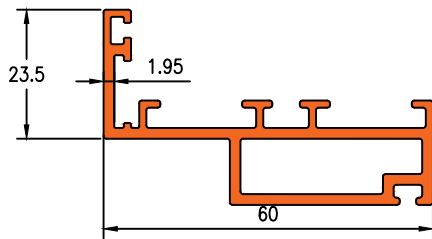

Die No.19710

0.441KG/M

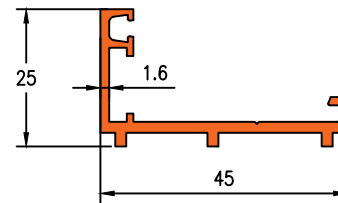

Die No.16268

1.839KG/M

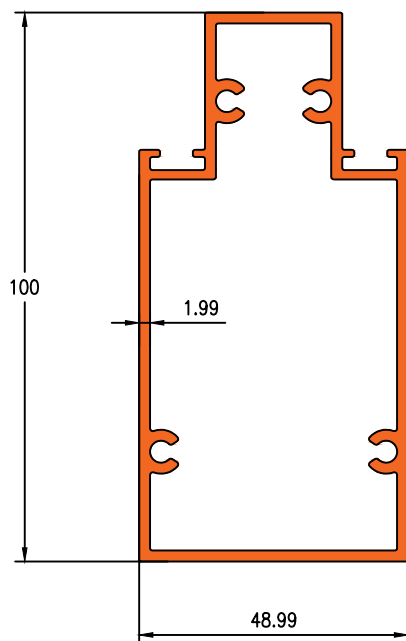



Die No.16262

1.460KG/M

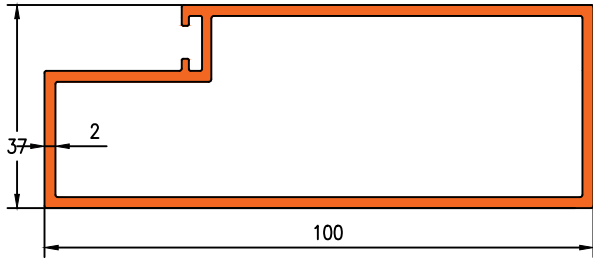

Die No.16263

2.159KG/M

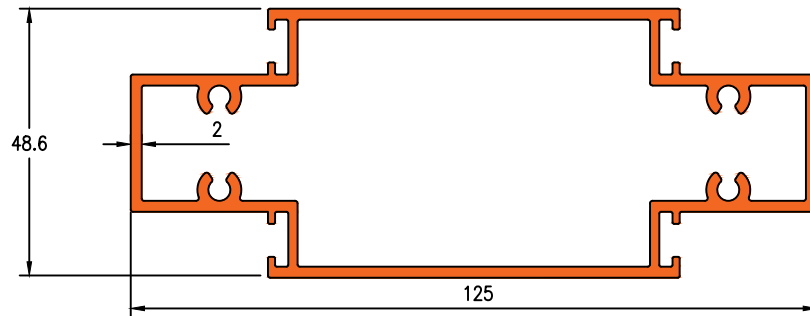

Die No.16264

1.754KG/M

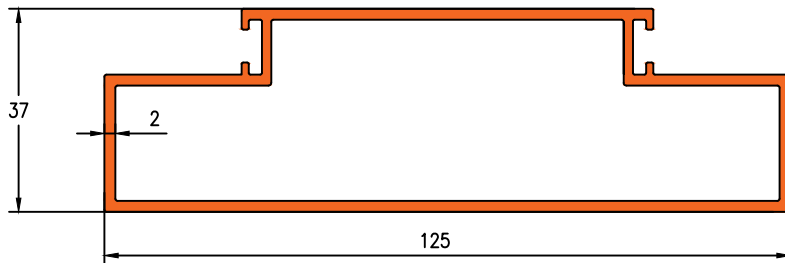



Die No.19431

1.439KG/M

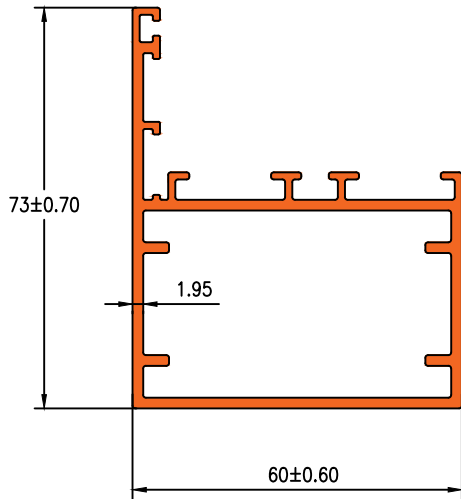

Die No.19539

0.769KG/M

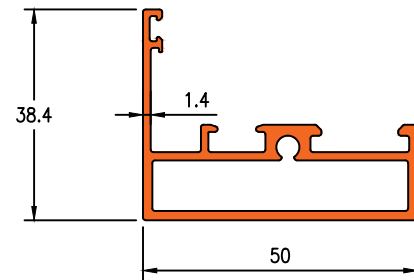

Die No.19540

1.691KG/M

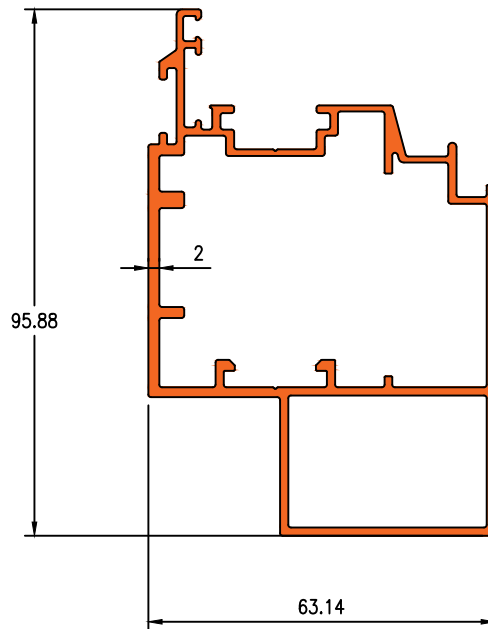

Die No.19541

0.186KG/M

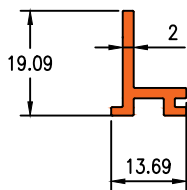

Die No.9027

0.812KG/M

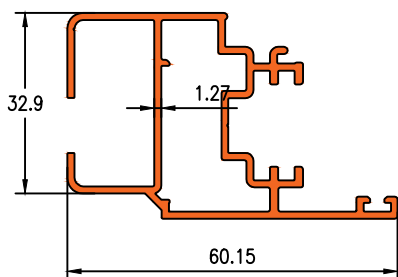

Die No.9028

0.610KG/M

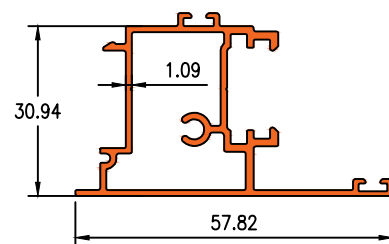



Darshan Extrusions Pvt. Ltd.

Die No.19664

1.354KG/M

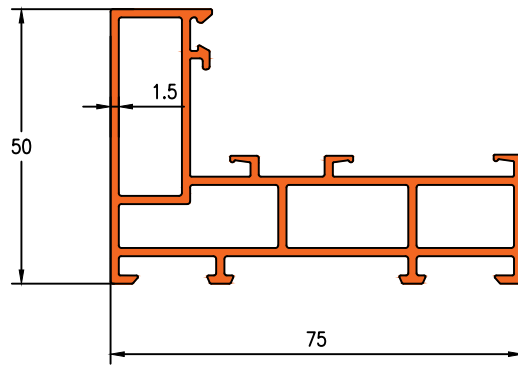

Die No.19665

0.395KG/M

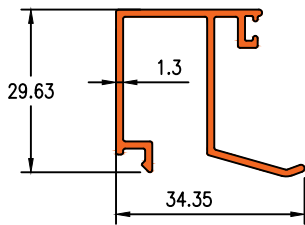

Die No.21174

0.944KG/M

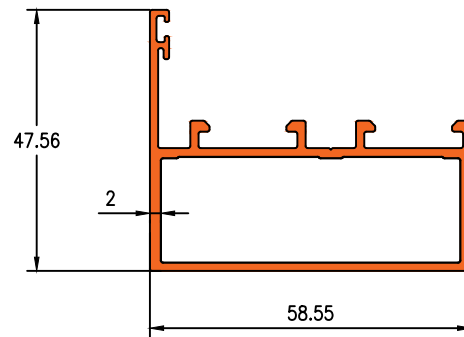

Die No.21175

1.979KG/M

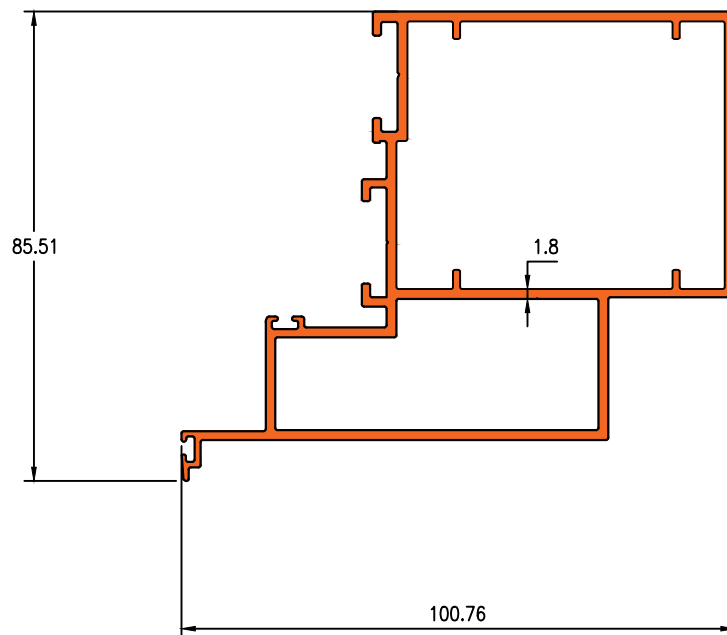



Darshan Extrusions Pvt. Ltd.

Die No. 2871

0.755Kg/m

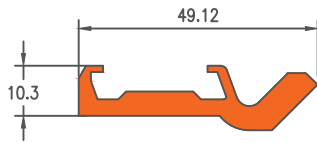

Die No. 2870

0.820Kg/m

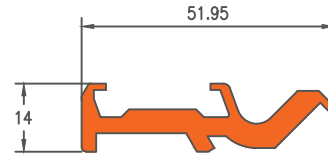

Die No. 28106

0.672Kg/m

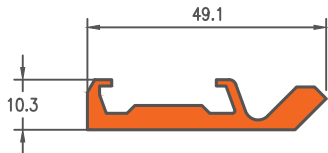

Die No. 28107

0.672Kg/m

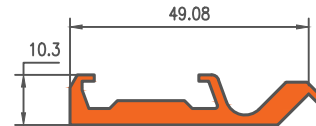

Die No. 19179

0.664Kg/m

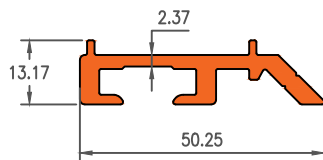

Die No. 19421

0.604Kg/m

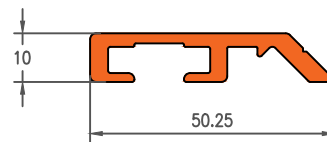

Die No. 2873

1.258Kg/m

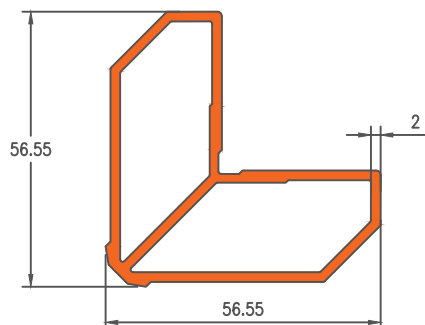

Die No. 2874

1.247Kg/m

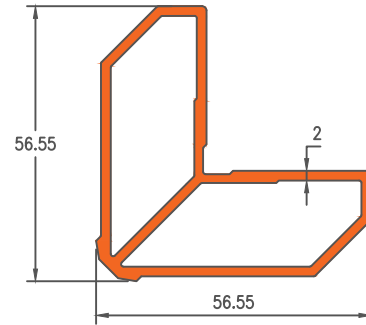

CORNER CLEATS



Darshan Extrusions Pvt. Ltd.

Die No. 2883

1.363Kg/m

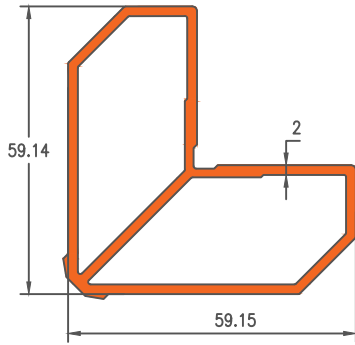

Die No. 13002

2.062Kg/m

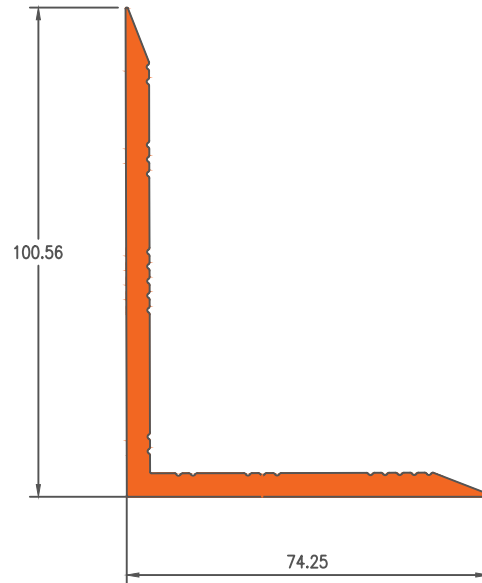

Die No. 16044

0.565Kg/m

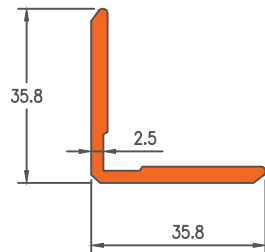

Die No. 7090

1.236Kg/m

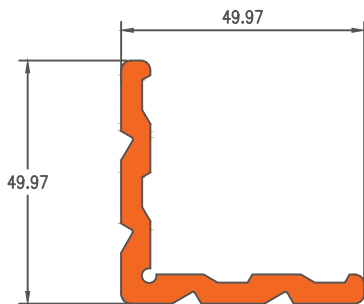

Die No. 19136

1.706Kg/m

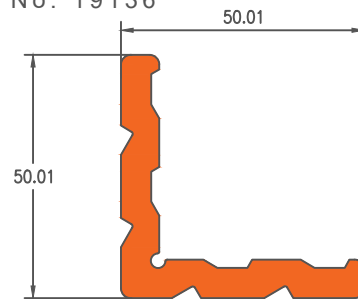

Die No. 16052

1.052Kg/m

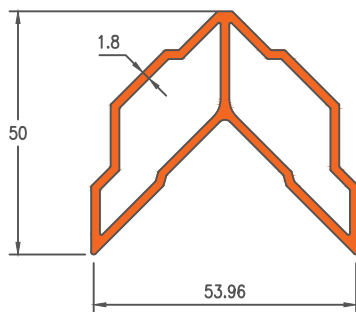

Die No. 16053

1.241Kg/m

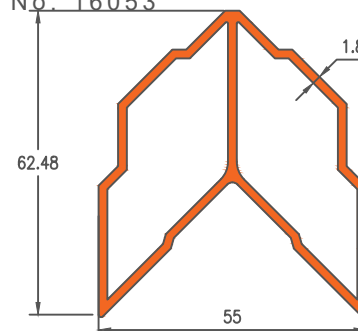

CORNER CLEATS



Darshan Extrusions Pvt. Ltd.

Die No. 1415

0.715Kg/m

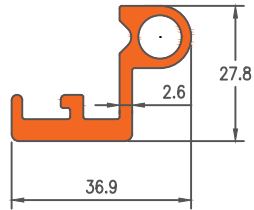

Die No. 1417

0.728Kg/m

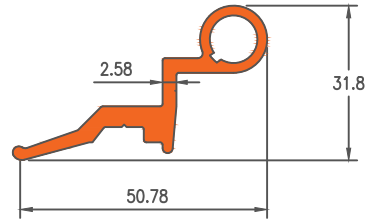

Die No. 1416

0.672Kg/m

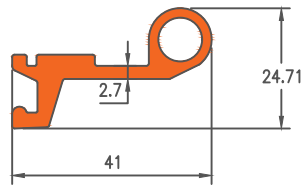

Die No. 1418

0.716Kg/m

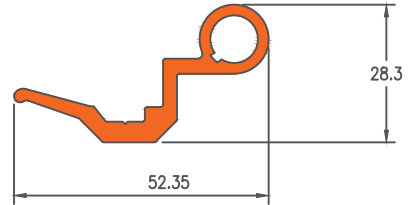

Die No. 1335

0.885Kg/m

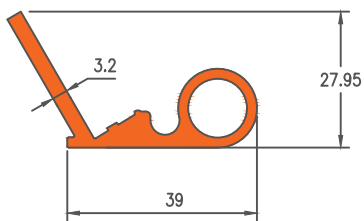

Die No. 1336

0.567Kg/m

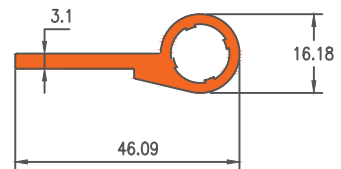

Die No. 19058

0.672Kg/m

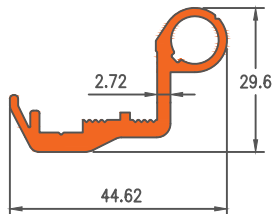

Die No. 19385

0.811Kg/m

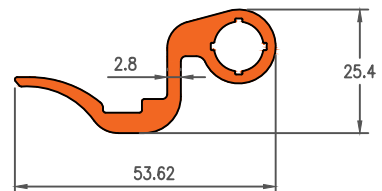



Darshan Extrusions Pvt. Ltd.

Die No. 19384

0.857Kg/m

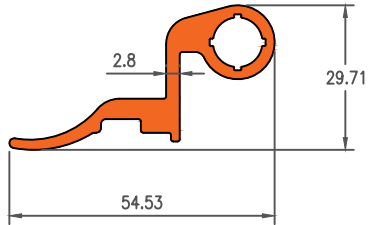

HINDGE



Die No.19703

1.912Kg/m

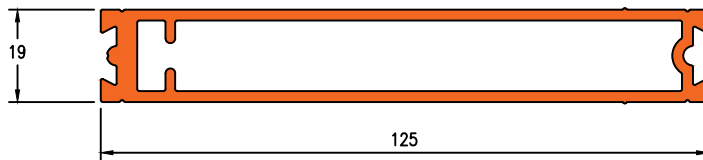

Die No.19704

1.993Kg/m

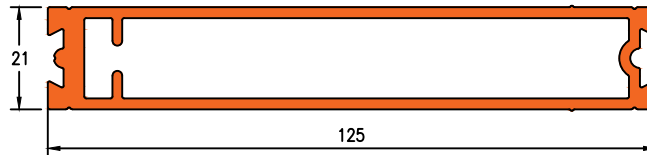

Die No.19204

1.325Kg/m

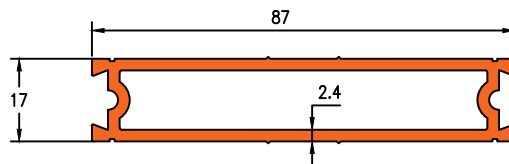

BEARING



Darshan Extrusions Pvt. Ltd.

Die No.10260

0.255Kg/m

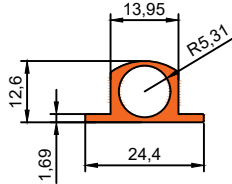

Die No.10068

0.129Kg/m

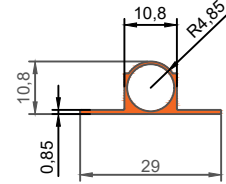

Die No.10034

0.168Kg/m

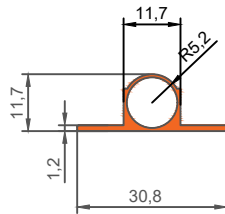

Die No.10092

0.313Kg/m

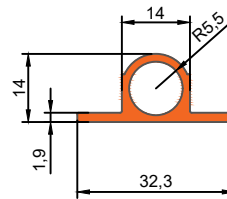

Die No.10093

0.434Kg/m

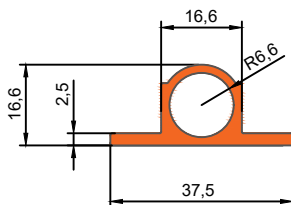

Die No.19508

0.203Kg/m

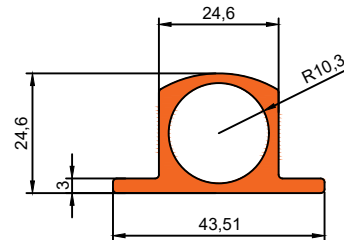

Die No.19509

0.213Kg/m

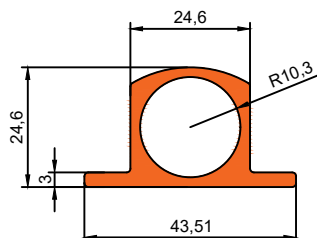

Die No.19510

0.390Kg/m

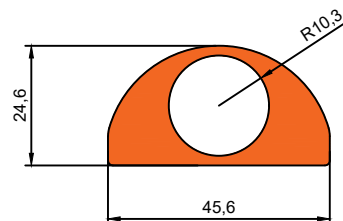

TOWER BOLTS



Die No.19511

0.259Kg/m

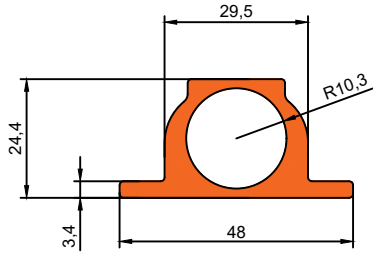

TOWER BOLTS



Die No.19419

0.742 Kg/m

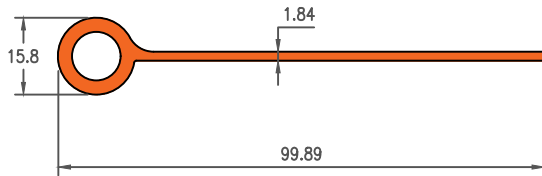



Darshan Extrusions Pvt. Ltd.

Die No. 7038

0.097 Kg/m

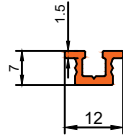

Die No. 7107

0.230 Kg/m

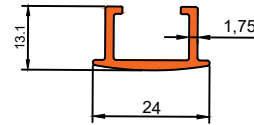

Die No. 7052

0.193 Kg/m

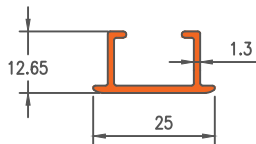

Die No. 1337

0.181 Kg/m

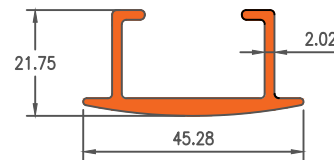

Die No. 19072

0.292 Kg/m

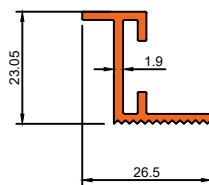

Die No. 19073

0.488 Kg/m

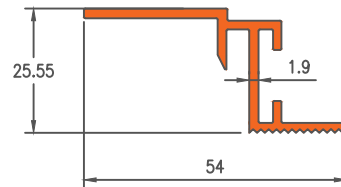

Die No. 5229

0.291 Kg/m

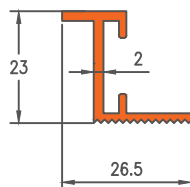

Die No. 5230

0.490 Kg/m

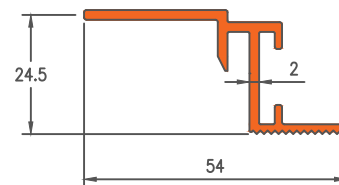

HARDWARE



Darshan Extrusions Pvt. Ltd.

Die No. 19063

0.250Kg/m

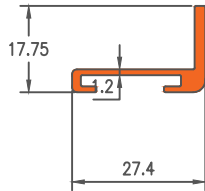

Die No. 19064

0.240Kg/m

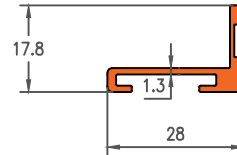

Die No. 19109

0.381Kg/m

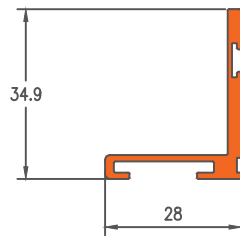

Die No. 1005

0.261Kg/m

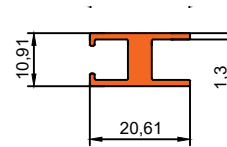

Die No. 19071

0.618Kg/m

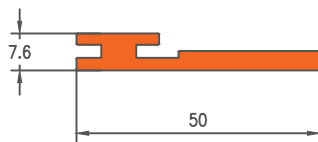

Die No. 5231

0.755Kg/m

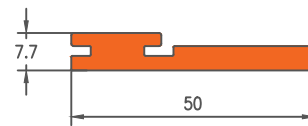

Die No. 1385

0.294Kg/m

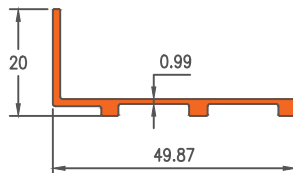

Die No. 1386

0.187Kg/m

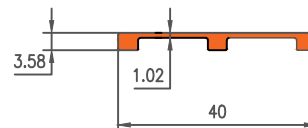



Darshan Extrusions Pvt. Ltd.

Die No. 19103

0.075Kg/m

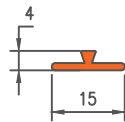

Die No. 1270

0.165Kg/m

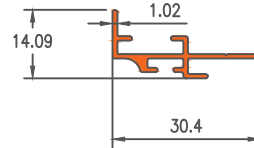

Die No. 1306

0.081Kg/m

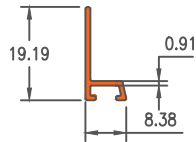

Die No. 19092

0.421Kg/m

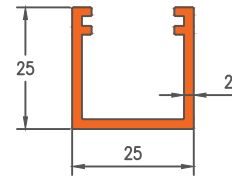

Die No. 19105

0.162Kg/m

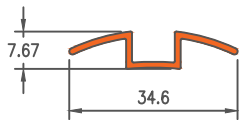

Die No. 19100

0.415Kg/m

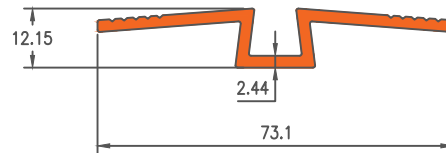

Die No. 19694

0.327Kg/m

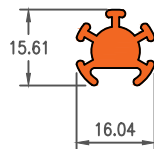

Die No. 16501

0.199Kg/m

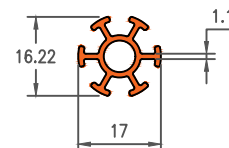



Darshan Extrusions Pvt. Ltd.

Die No. 19684

0.136Kg/m

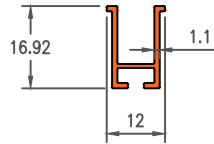

Die No. 19683

1.090Kg/m

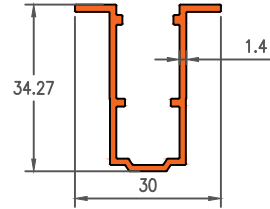

Die No.19468

0.413Kg/m

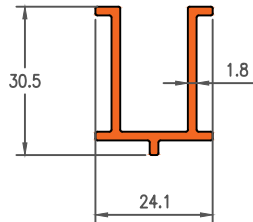

Die No. 7140

0.457Kg/m

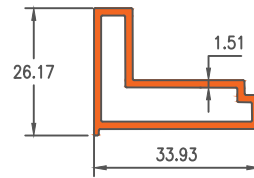

Die No. 19047

0.472Kg/m

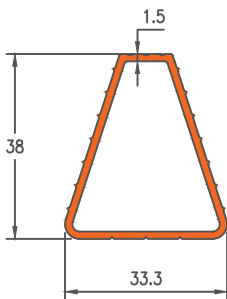

Die No. 19091

1.193Kg/m

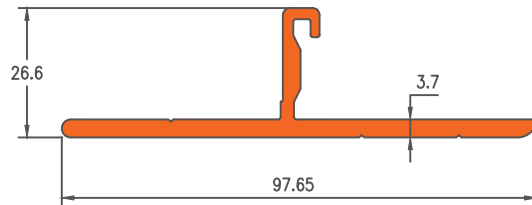

Die No.19013

0.854Kg/m

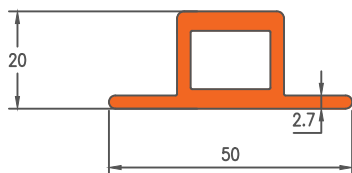

Die No.19924

0.345Kg/m

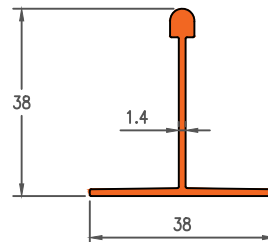



Darshan Extrusions Pvt. Ltd.

Die No. 19012

2.758 Kg/m

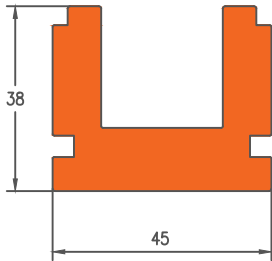

Die No. 7058

2.149Kg/m

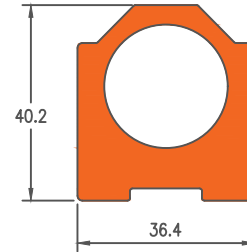

Die No. 19812

1.715Kg/m

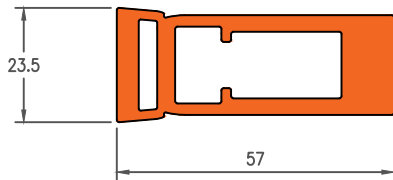

Die No. 19832

1.770Kg/m

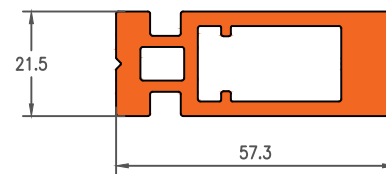

Die No. 19120

1.918Kg/m

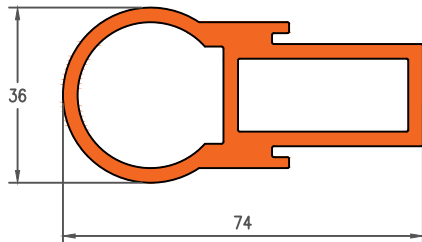

Die No. 19647

0.939Kg/m

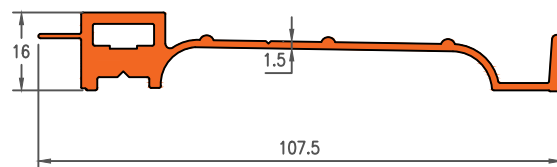

Die No. 16046

0.517Kg/m

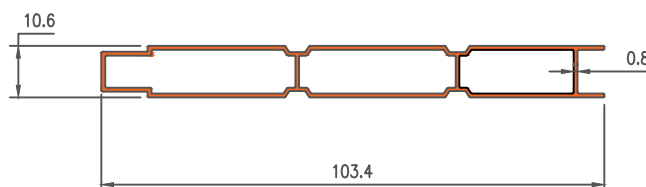



Darshan Extrusions Pvt. Ltd.

Die No. 19112

0.521Kg/m

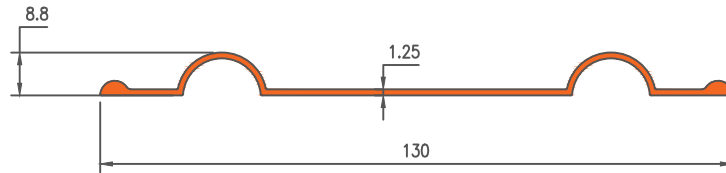

Die No. 19084

1.689Kg/m

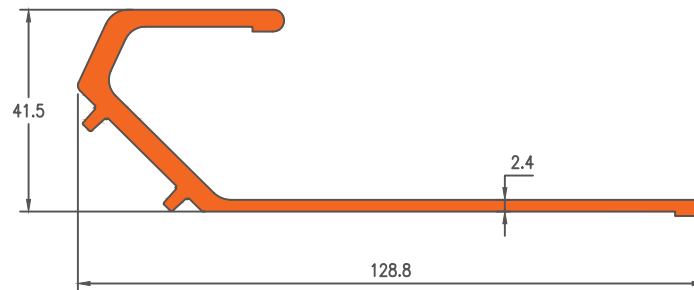

Die No. 16186

0.962Kg/m

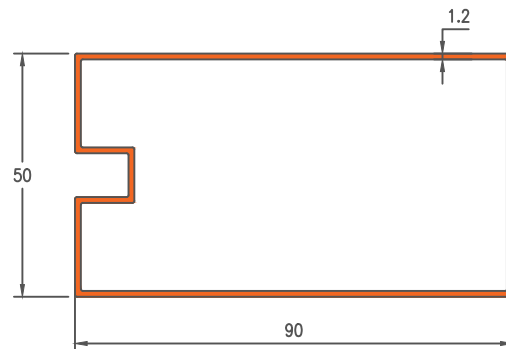

Die No. 1205

0.619Kg/m

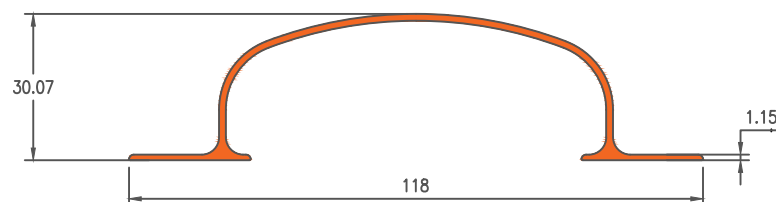



Darshan Extrusions Pvt. Ltd.

Die No. 1206

0.907Kg/m

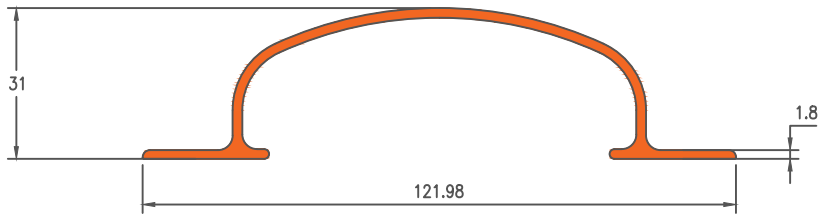

Die No. 19705

0.947Kg/m

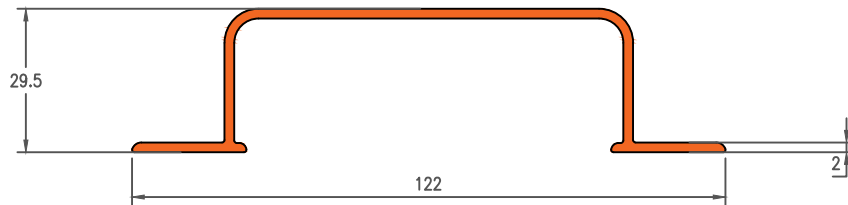

Die No. 10201

0.988Kg/m

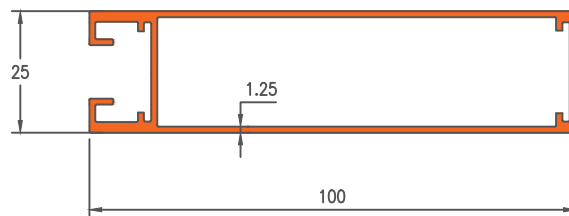

Die No. 16231

1.706 Kg/m

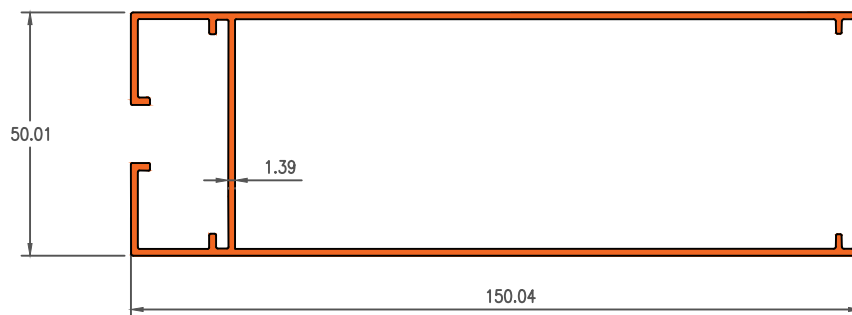



Darshan Extrusions Pvt. Ltd.

Die No. 19052 1.697 Kg/m

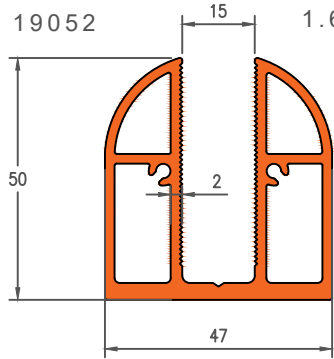

Die No. 19702 1.095 Kg/m

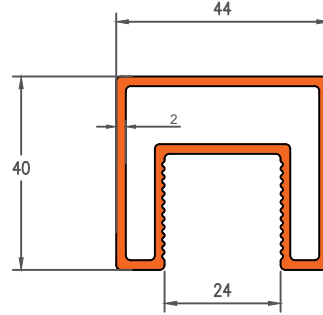

Die No. 19603 1.365 Kg/m

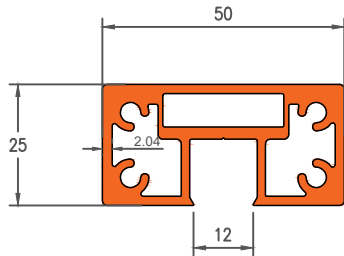

Die No. 7053 1.387 Kg/m

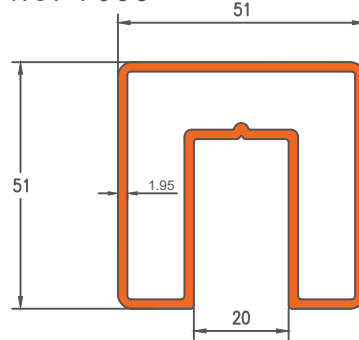

Die No. 7127 1.028 Kg/m

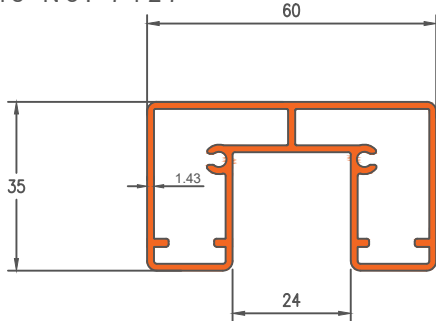

Die No. 19150 0.967 Kg/m

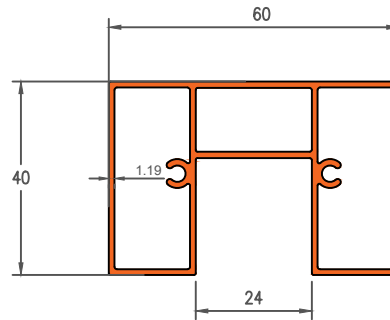

Die No. 20061 1.455 Kg/m

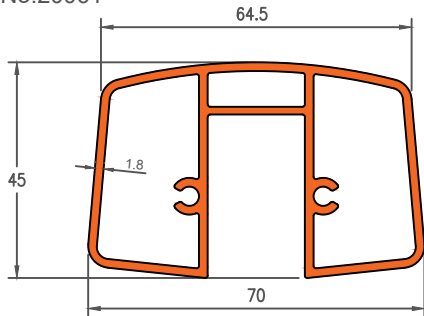

Die No. 21076 1.199 Kg/m

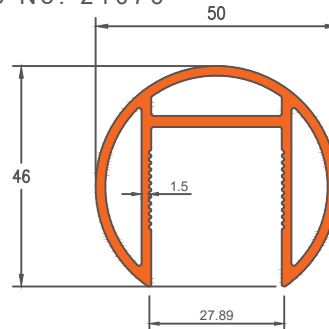

RAILING



Darshan Extrusions Pvt. Ltd.

Die No. 1391 0.833Kg/m

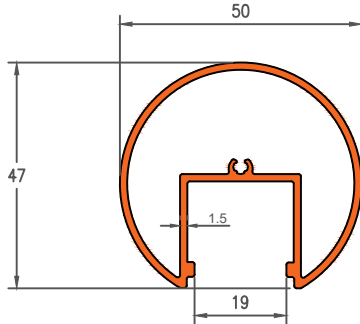

Die No. 19151 0.925Kg/m

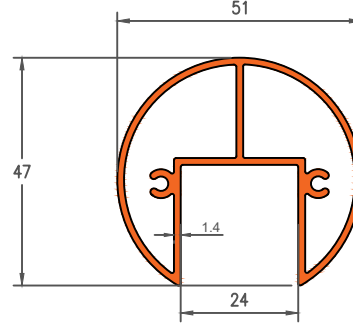

Die No. 1390 0.358Kg/m

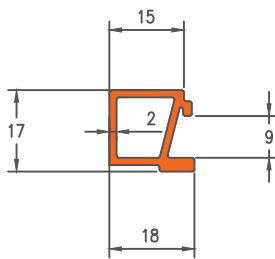

Die No. 19118 0.260Kg/m

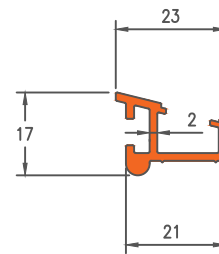

Die No. 7118 0.295Kg/m

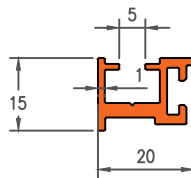

Die No. 19154 0.062Kg/m

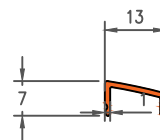

Die No. 20090 1.392Kg/m

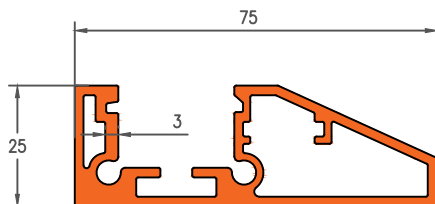

Die No. 19985 1.829Kg/m

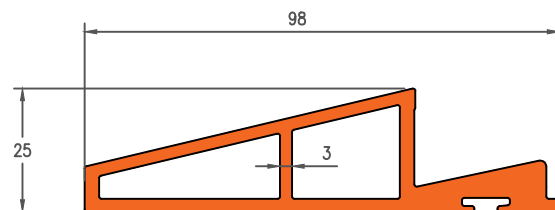

RAILING



Darshan Extrusions Pvt. Ltd.

Die No. 20071

0.050 KG/M

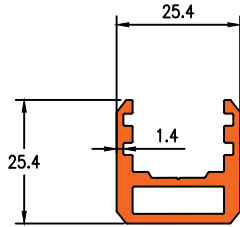

Die No. 19207

1.134 KG/M

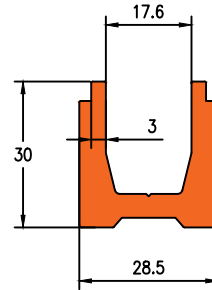

Die No. 19010

1.569 KG/M

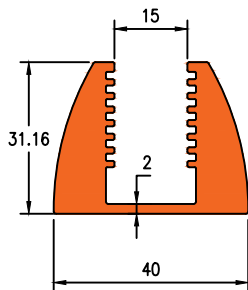

Die No. 16600

1.198 KG/M

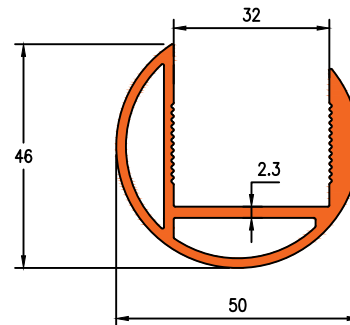

Die No. 21032

2.435 KG/M

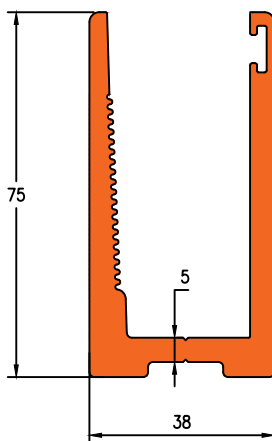

Die No. 19141

5.854 KG/M

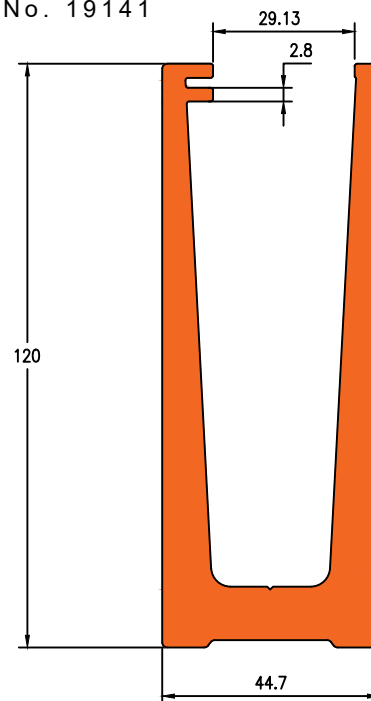

RAILING



Darshan Extrusions Pvt. Ltd.

Die No. 9555

4.905KG/M

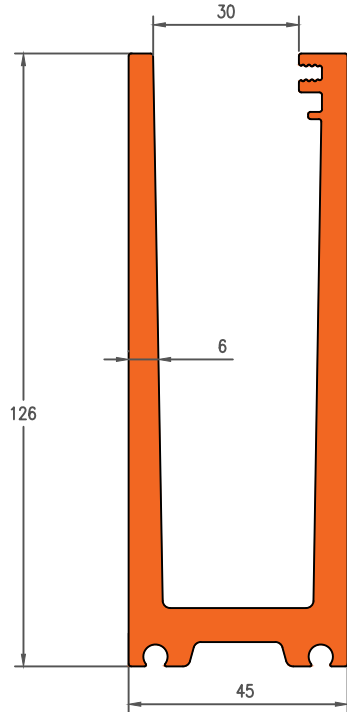

Die No. 9260

3.439KG/M

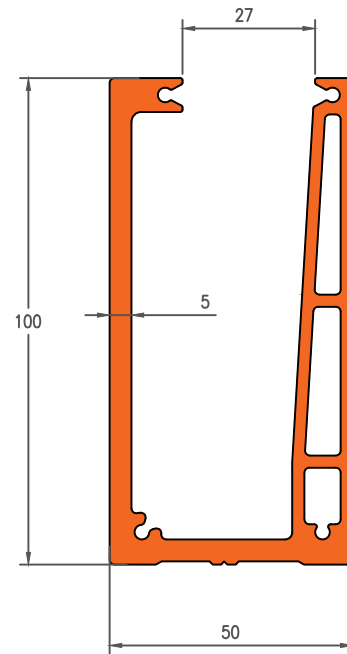

Die No. 1411

2.815KG/M

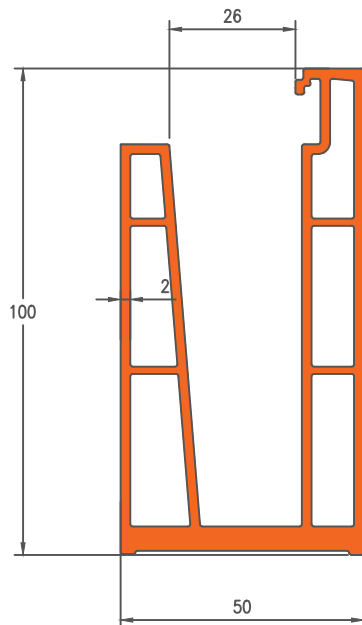

CLIP :-1390

Die No. 19551

2.765 KG/M

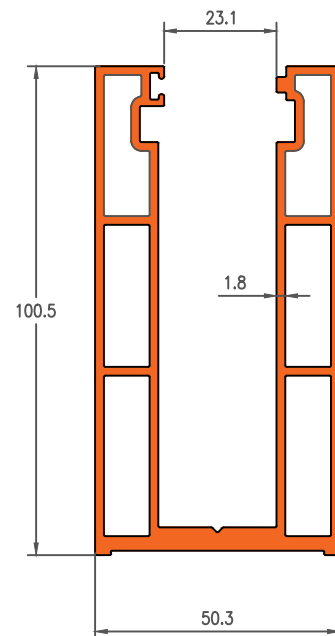

RAILING



Darshan Extrusions Pvt. Ltd.

Die No. 9259

2.683Kg/m

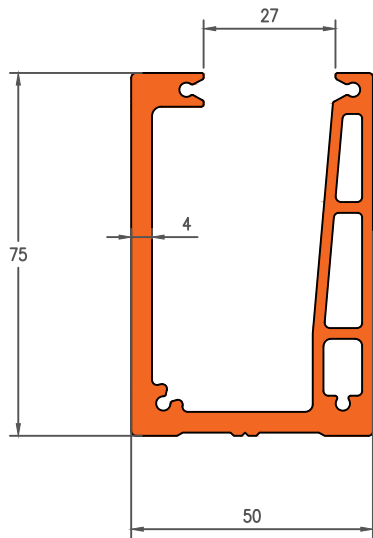

Die No. 21061

2.211Kg/m

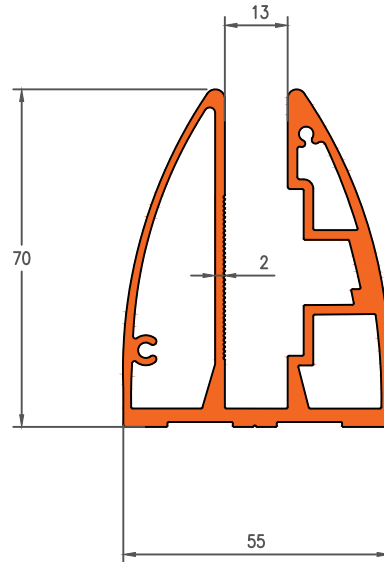

Die No. 19149

3.15Kg/m

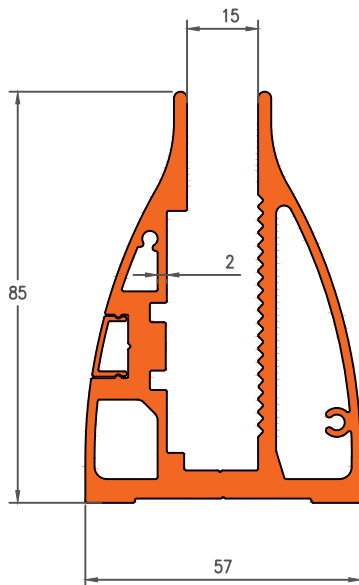

Die No. 7117

4.428 Kg/m

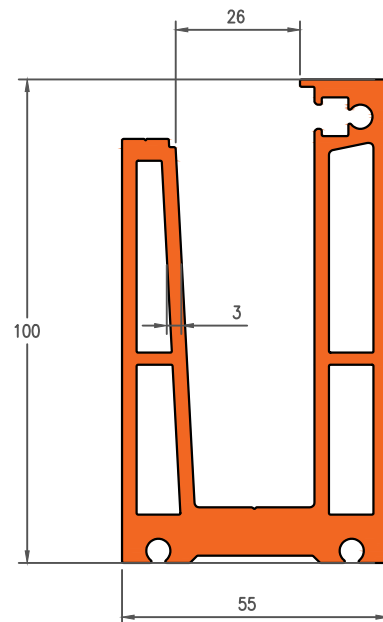

CLIP :-7118

RAILING



Darshan Extrusions Pvt. Ltd.

Die No. 7136

1.944 Kg/m

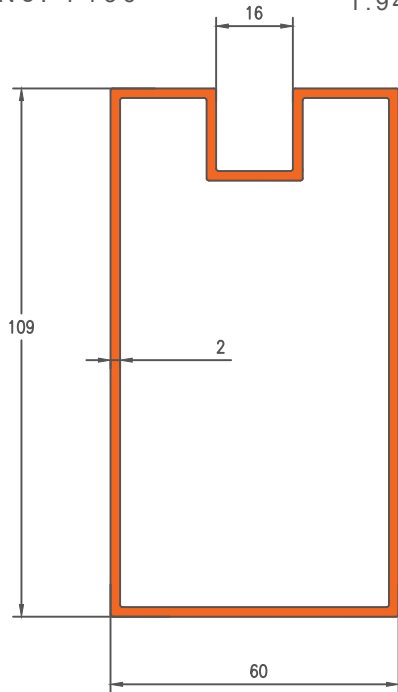

Die No.P-8041

4.991Kg/m

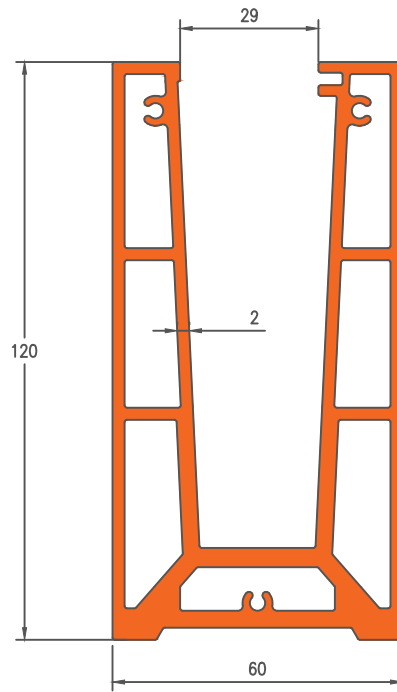

Die No.9565

4.244Kg/m

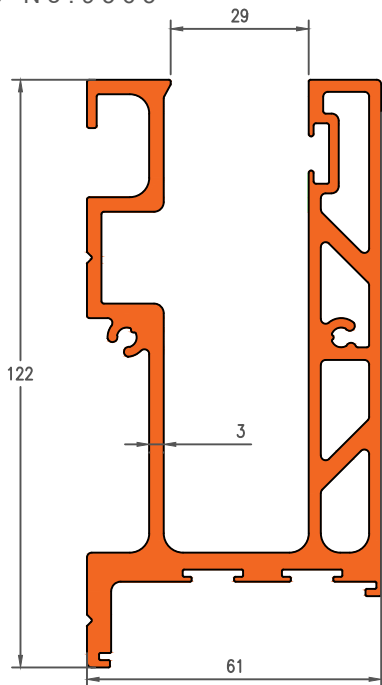

Die No. 19549

6.039Kg/m

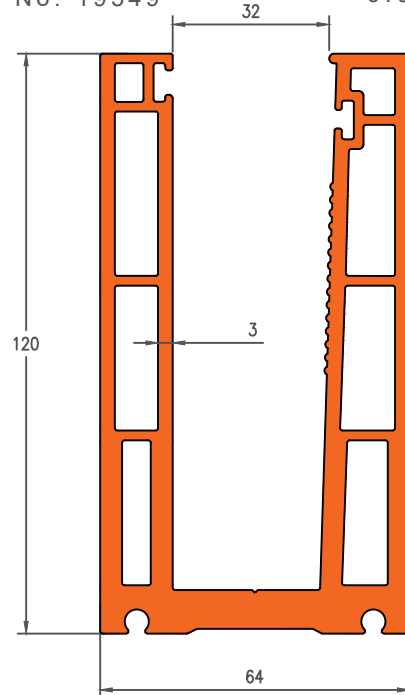

RAILING



Darshan Extrusions Pvt. Ltd.

Die No. 19116 31 5.397Kg/m

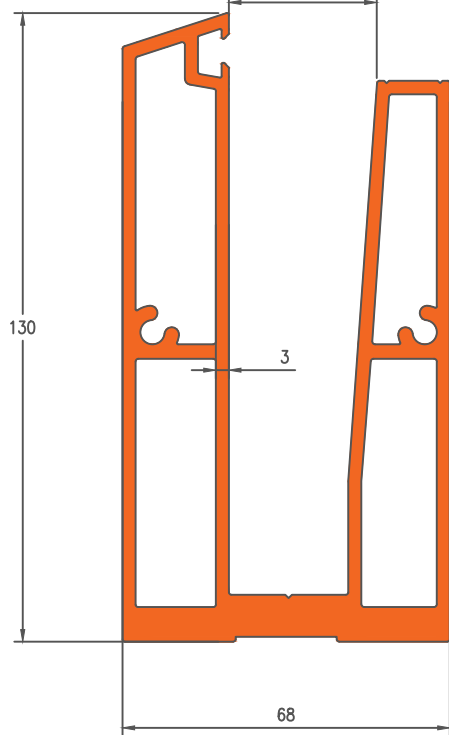

CLIP :-19118

Die No. 19117 31 4.825Kg/m

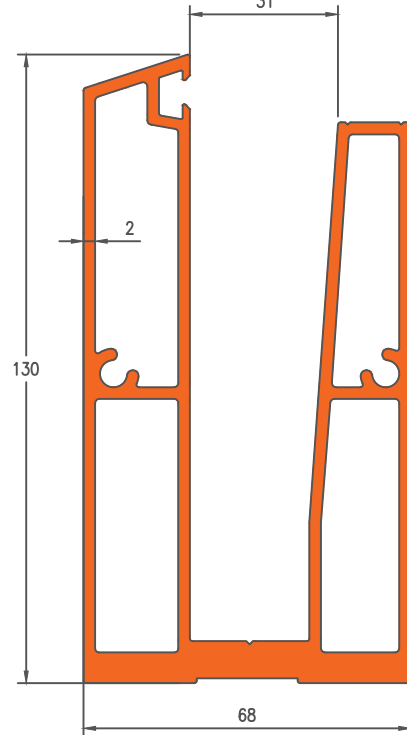

CLIP :-19118

Die No. 19553 2.822Kg/m

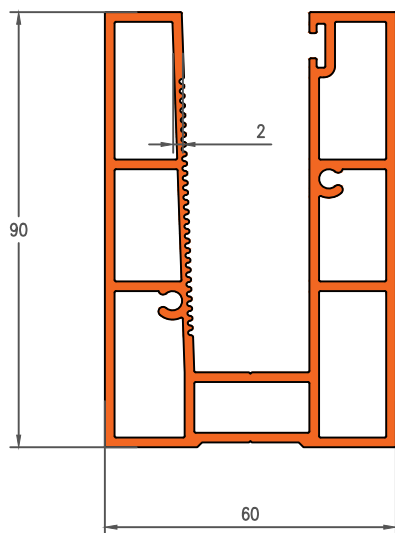

Die No. 9013 6.127Kg/m

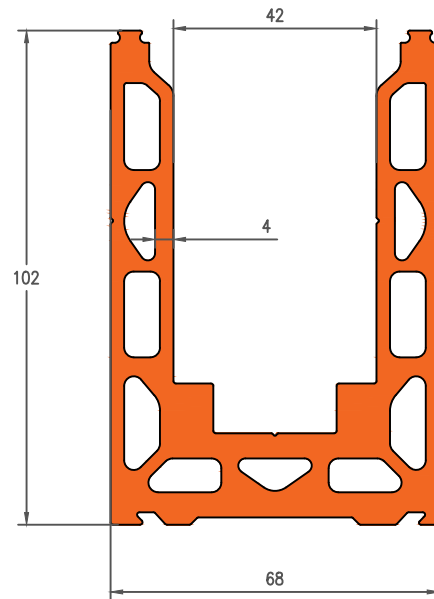

RAILING



Darshan Extrusions Pvt. Ltd.

Die No. 9564 6.114Kg/m

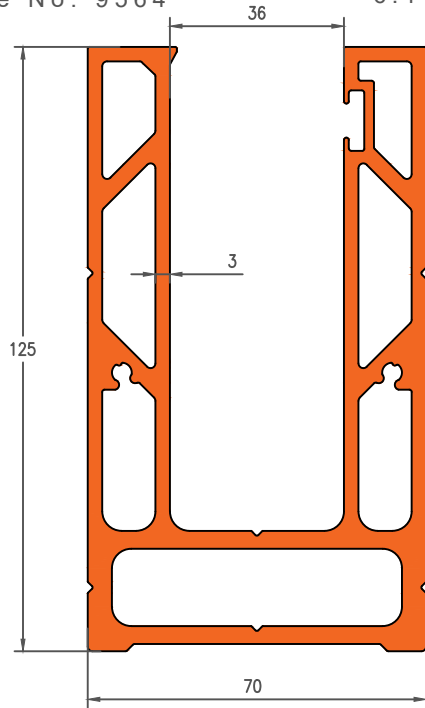

Die No. 19559 6.105Kg/m

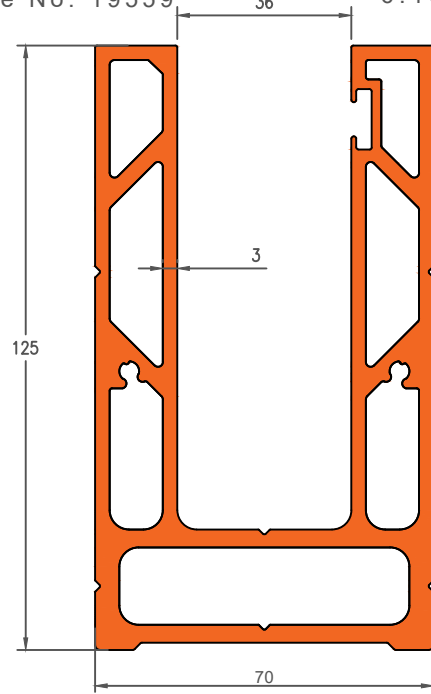

Die No. 19148 7.278Kg/m

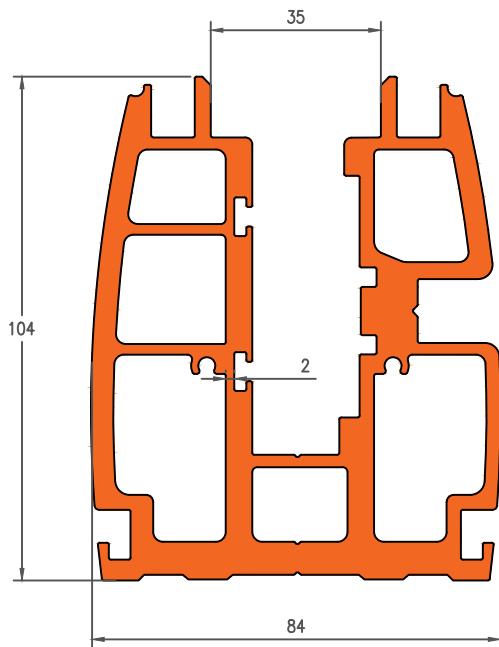

Die No. 9162 5.424Kg/m

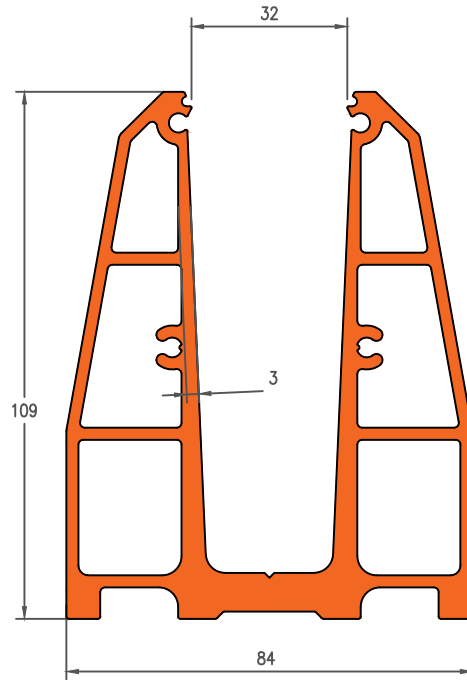

RAILING



Darshan Extrusions Pvt. Ltd.

Die No. 9528

8.166KG/M

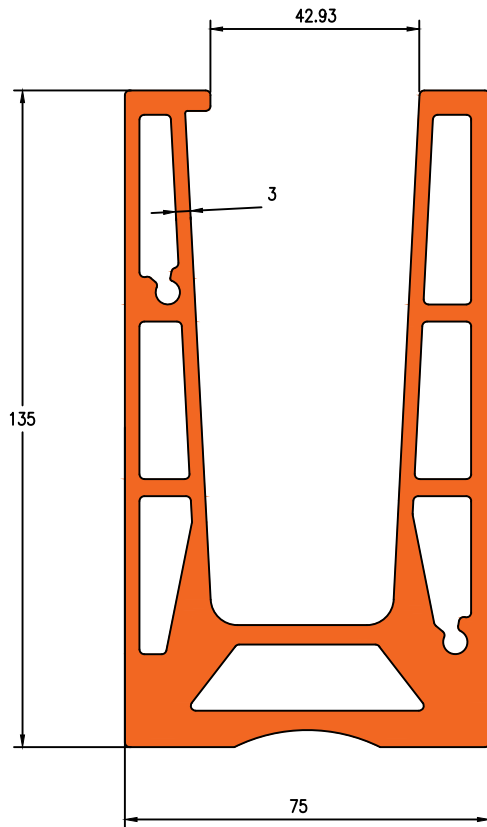

Die No. 19982

6.021 KG/M

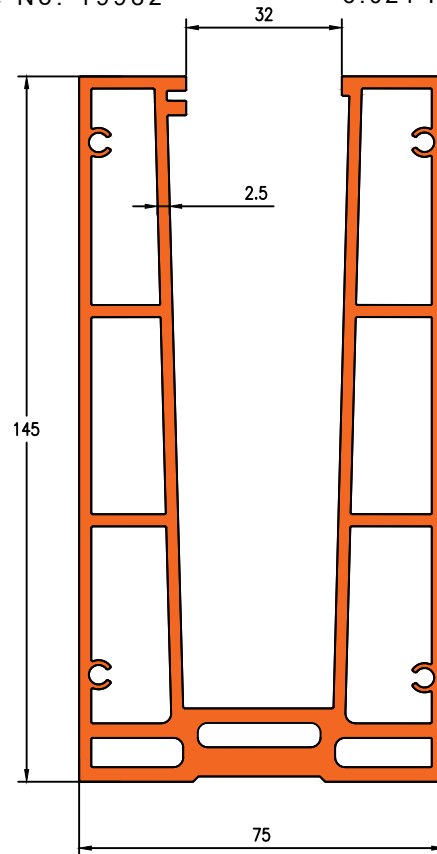

Die No. 20067

0.672KG/M

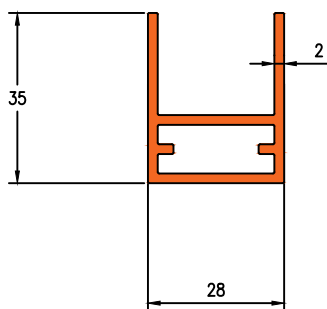

RAILING



Darshan Extrusions Pvt. Ltd.

Die No. 9067

8.228 Kg/m

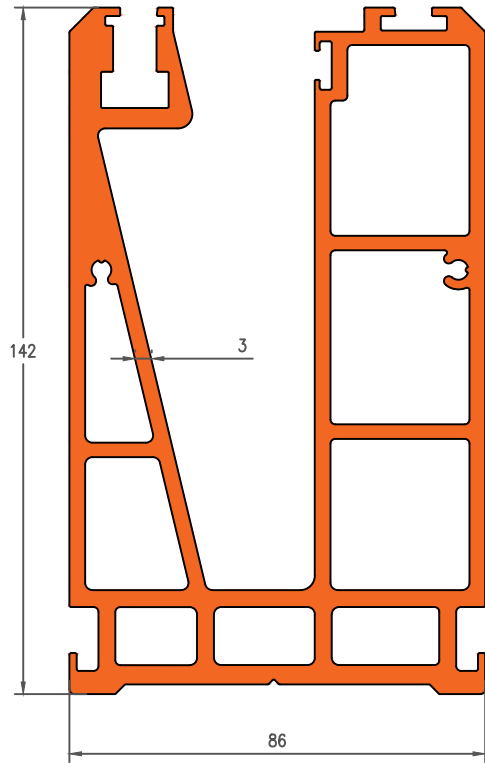

Die No. 19942

0.764Kg/m

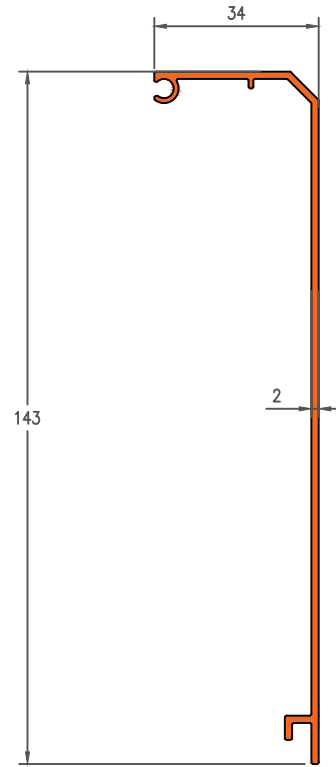

RAILING



Die No. 9065

5.577KG/M

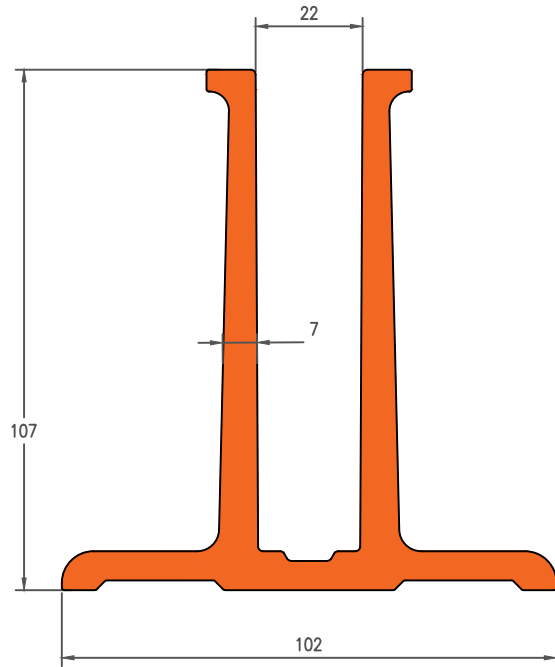

Die No. 19560

4.885KG/M

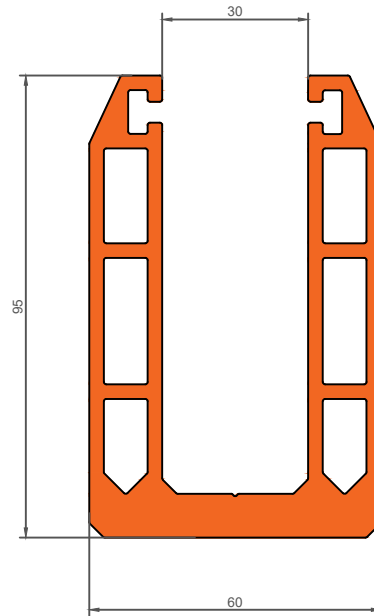

RAILING



Die No. 9012

6.424 KG/M

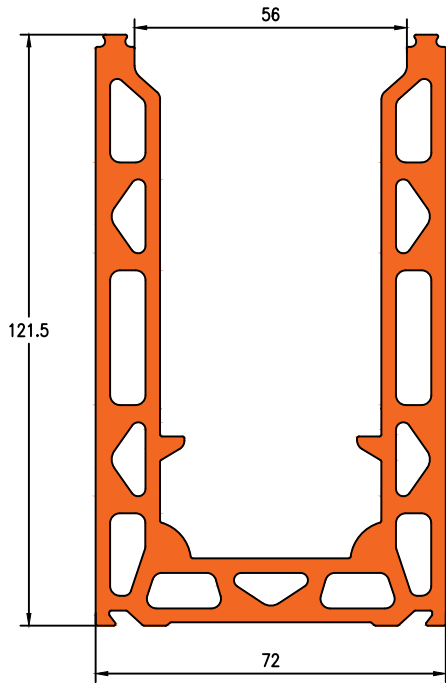

RAILING



Darshan Extrusions Pvt. Ltd.

Die No. 1258

0.464KG/M

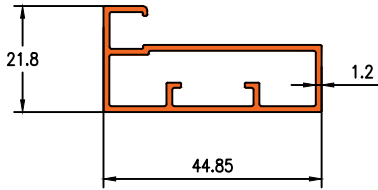

Die No. 1257

0.616KG/M

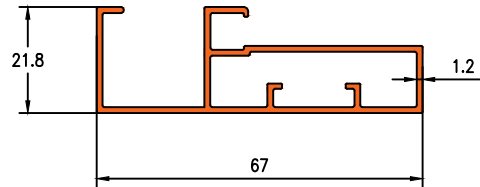

Die No. 7036

0.478KG/M

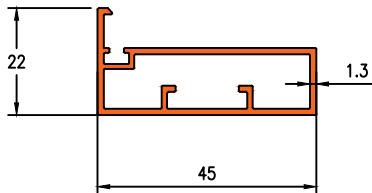

Die No. 7035

0.633KG/M

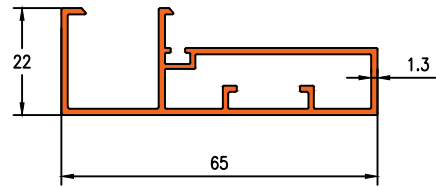

Die No. 7033

0.552KG/M

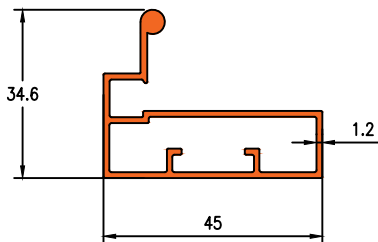

Die No. 7034

0.714KG/M

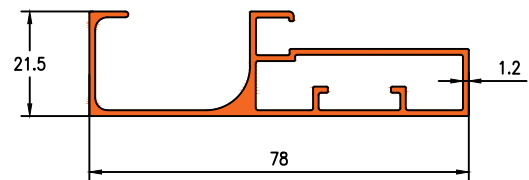

Die No. 7031

0.356KG/M

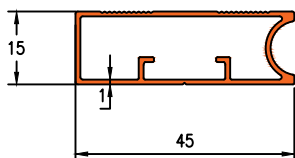

Die No. 7032

0.533KG/M

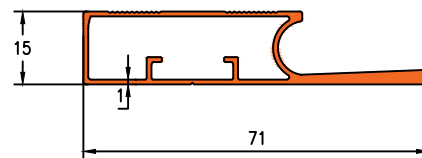

MODULAR



Darshan Extrusions Pvt. Ltd.

Die No.19088

0.429KG/M

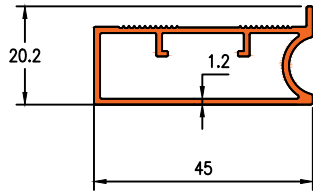

Die No.19089

0.643KG/M

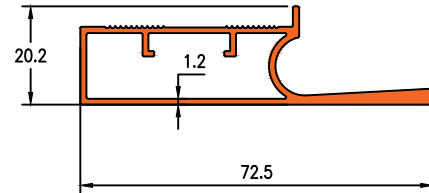

Die No.7130

0.620KG/M

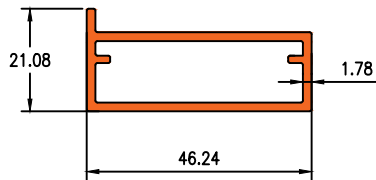

Die No.7131

0.726KG/M

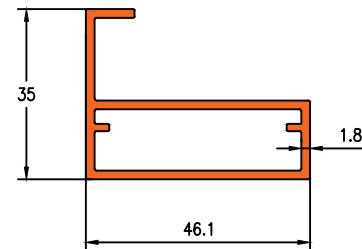

Die No.7087

0.710KG/M

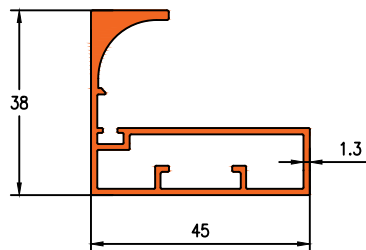

Die No.27027

0.359KG/M

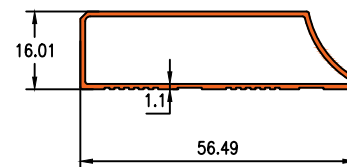

Die No.27026

0.473KG/M

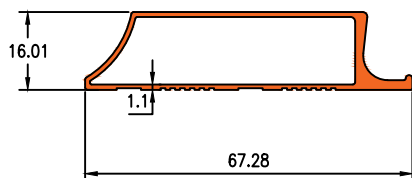

Die No.27028

0.670KG/M

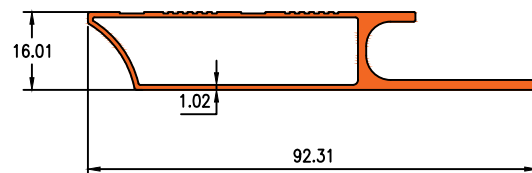

MODULAR



Darshan Extrusions Pvt. Ltd.

Die No.19078

0.608KG/M

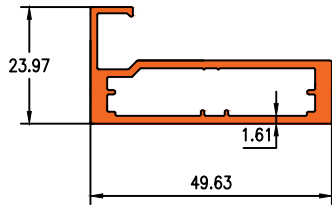

Die No.19077

0.886KG/M

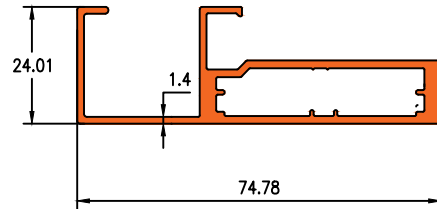

Die No.23143

0.387KG/M

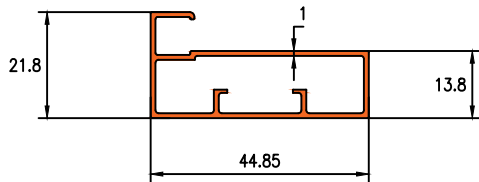

Die No.23144

0.536KG/M

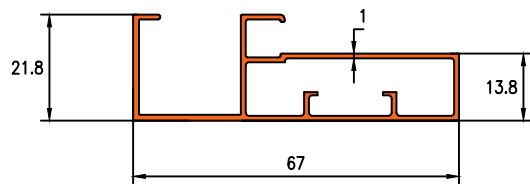

Die No.23145

0.474KG/M

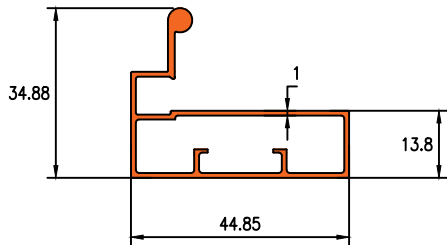

Die No.23146

0.315KG/M

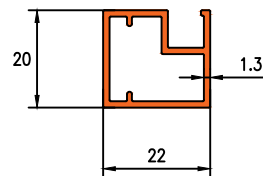

Die No.23147

0.406KG/M

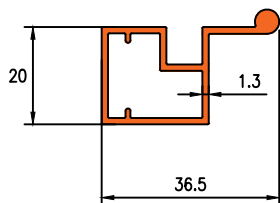

Die No.19807

0.946KG/M

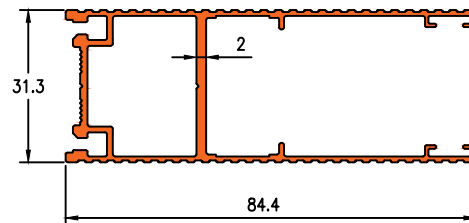

MODULAR



Darshan Extrusions Pvt. Ltd.

Die No.19808

0.311KG/M

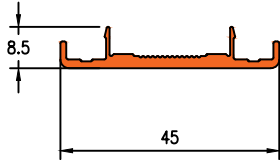

Die No.20112

0.291KG/M

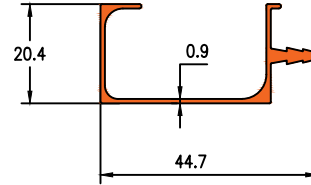

Die No.1259

0.368KG/M

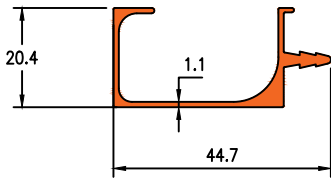

Die No.7088

0.494KG/M

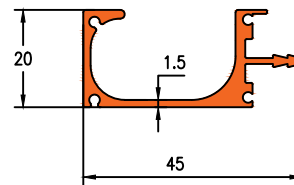

Die No.20048

0.439KG/M

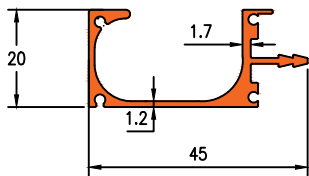

Die No.19383

0.352KG/M

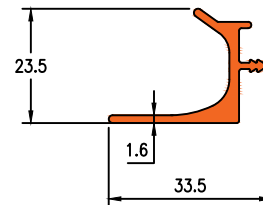

Die No.19011

0.560KG/M

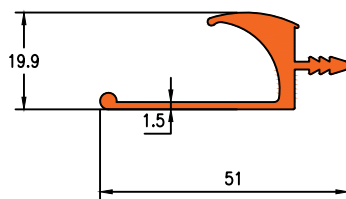

Die No.19119

0.299KG/M

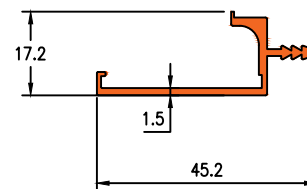

MODULAR



Darshan Extrusions Pvt. Ltd.

Die No.1289

0.504KG/M

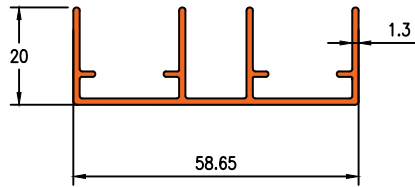

Die No.1292

0.316KG/M

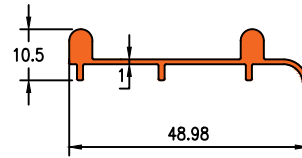

Die No.19471

0.406KG/M

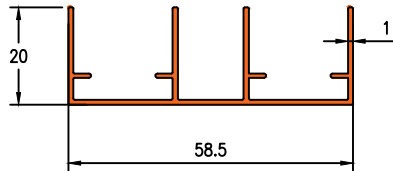

Die No.19472

0.276KG/M

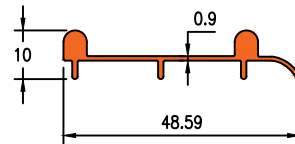

Die No.20109

0.325KG/M

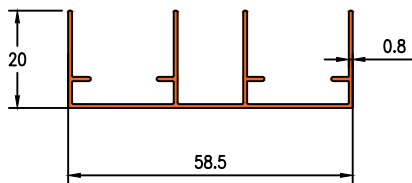

Die No.19124

0.240KG/M

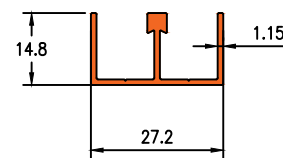

Die No.1291

0.253KG/M

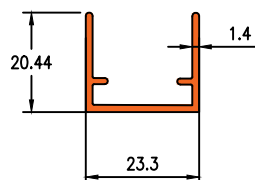

Die No.1294

0.130KG/M

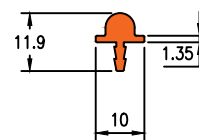

MODULAR



Darshan Extrusions Pvt. Ltd.

Die No.1295

0.113KG/M

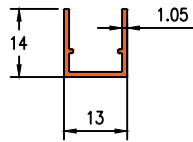

Die No.1290

0.118KG/M

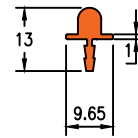

Die No.1293

0.131KG/M

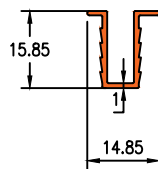

Die No.19026

0.424KG/M

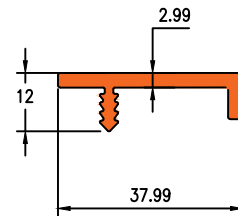

Die No.19068

0.100KG/M

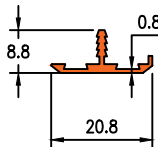

Die No.1500

0.273KG/M

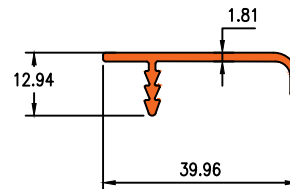

Die No.10009

0.726KG/M

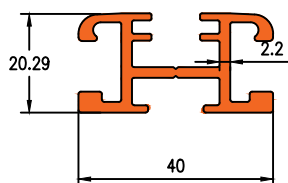

Die No.10010

0.516KG/M

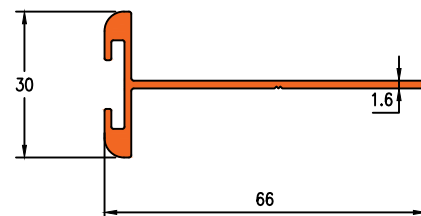

MODULAR



Darshan Extrusions Pvt. Ltd.

Die No.1235

0.341KG/M

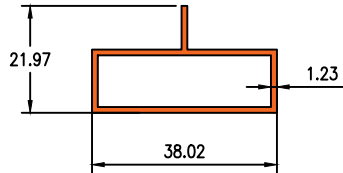

Die No.1236

0.339KG/M

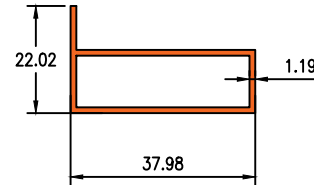

Die No.1485

0.126KG/M

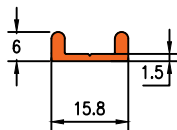

Die No.19125

0.129KG/M

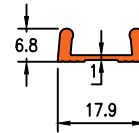

Die No.1484

0.173KG/M

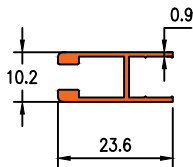

Die No.19123

0.279KG/M

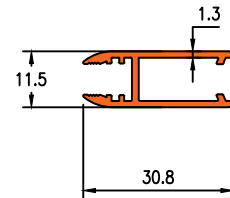

Die No.7024

0.163KG/M

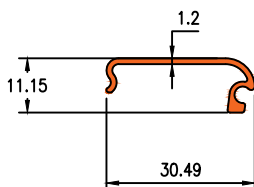

Die No.7025

0.255KG/M

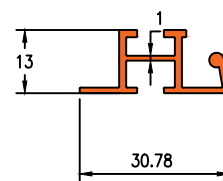

MODULAR



Darshan Extrusions Pvt. Ltd.

Die No.7040

0.461KG/M

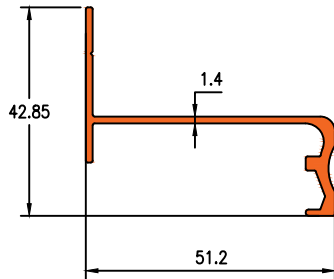

Die No.7041

0.380KG/M

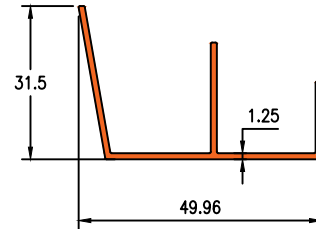

Die No.19967

0.188KG/M

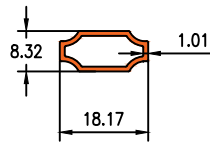

Die No.19668

0.737KG/M

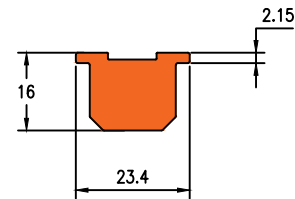

Die No.16410

0.467KG/M

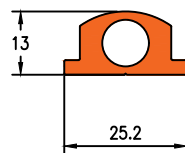

Die No.16412

0.631KG/M

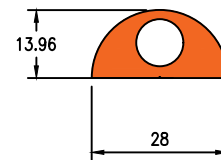

Die No.16411

0.539KG/M

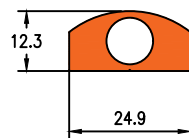

Die No.16413

0.577KG/M

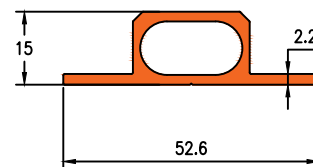

MODULAR



Darshan Extrusions Pvt. Ltd.

Die No.19498

0.542KG/M

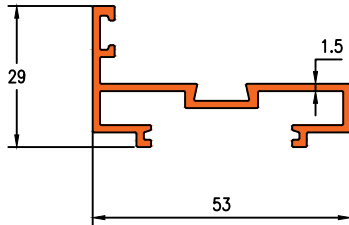

Die No.19499

0.233KG/M

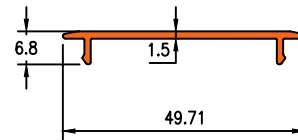

Die No. 19486

0.426 KG/M

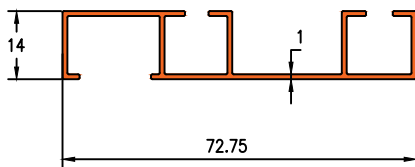

Die No. 19487

0.316 KG/M

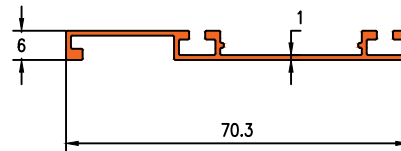

Die No. 20107

0.385 KG/M

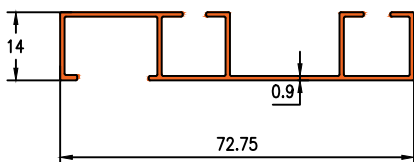

Die No. 20108

0.295 KG/M

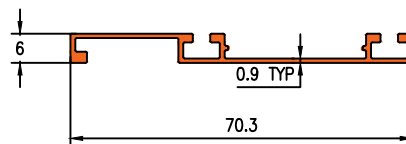

Die No. 20056

0.305 KG/M

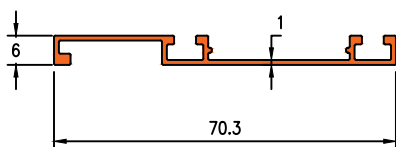

Die No. 19485

0.074 KG/M

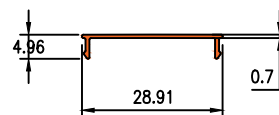

MODULAR



Darshan Extrusions Pvt. Ltd.

Die No. 21027

0.457 KG/M

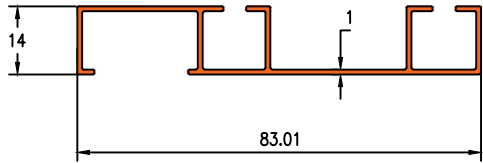

Die No. 21028

0.345 KG/M

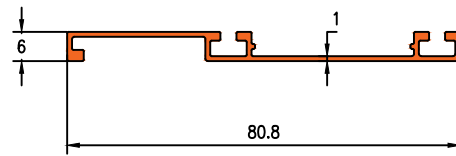

Die No. 21029

0.092 KG/M

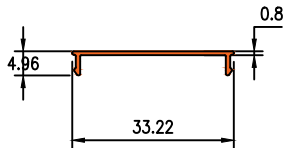

Die No. 21040

0.333 KG/M

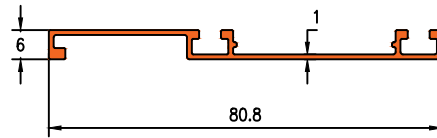

Die No. 19156

0.457 KG/M

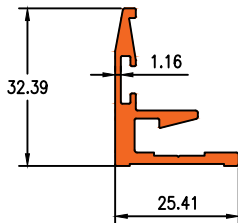

Die No. 19157

0.311 KG/M

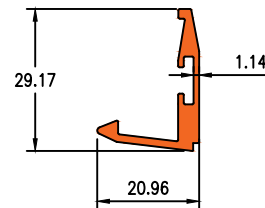

Die No. 1203

0.680 KG/M

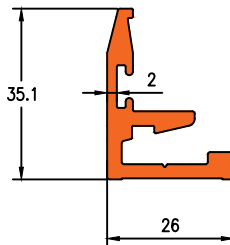

Die No. 1204

0.429 KG/M

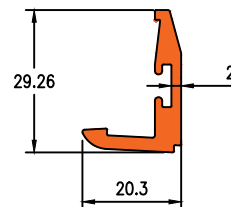

MODULAR



Darshan Extrusions Pvt. Ltd.

Die No. 19445

0.457 KG/M

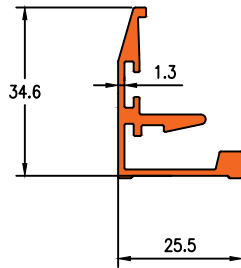

Die No. 19446

0.341 KG/M

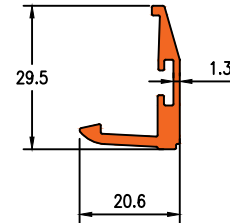

Die No. 20110

0.430 KG/M

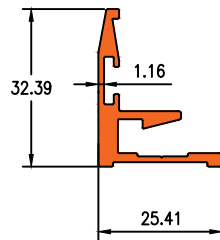

Die No. 20111

0.249 KG/M

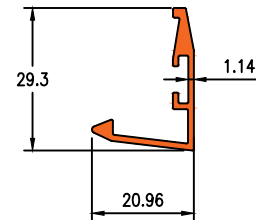

Die No. 20025

0.259 KG/M

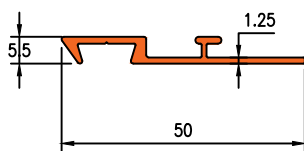

Die No. 20031

0.295 KG/M

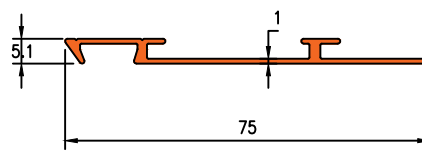

Die No. 20091

0.211 KG/M

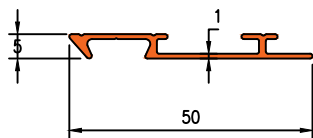

Die No. 20092

0.279 KG/M

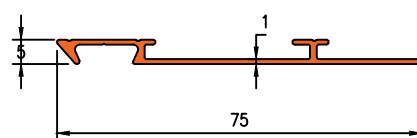

MODULAR



Darshan Extrusions Pvt. Ltd.

Die No.16522

0.388 KG/M

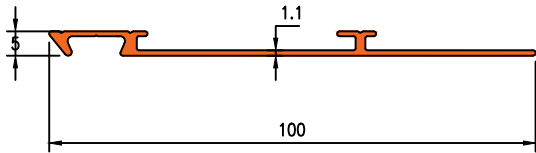

Die No.22072

0.354 KG/M

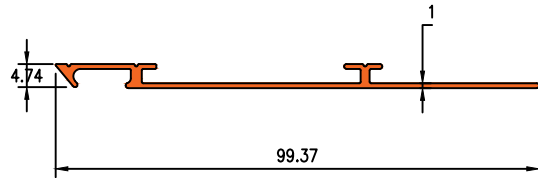

Die No.22073

0.201 KG/M

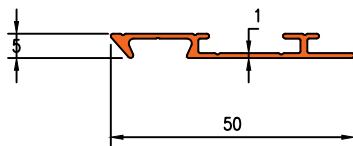

Die No.16406

0.375 KG/M

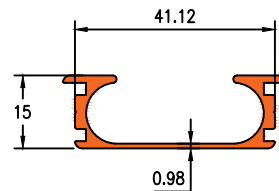

Die No.16405

0.299 KG/M

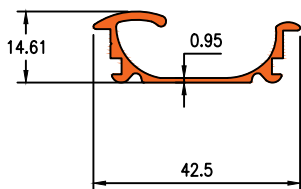

MODULAR



Darshan Extrusions Pvt. Ltd.

Die No.23024

0.730KG/M

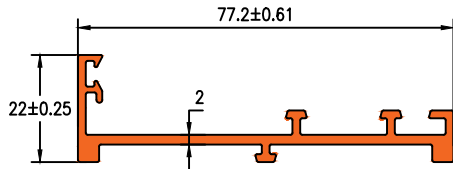

Die No.19754

1.193KG/M

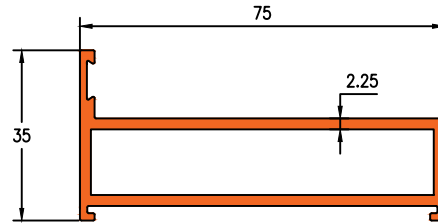

Die No.16402

0.319KG/M

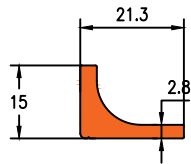

Die No.16403

0.859KG/M

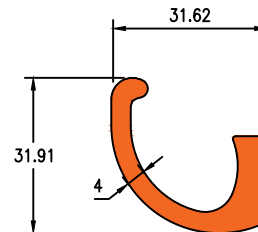

Die No.19742

0.559KG/M

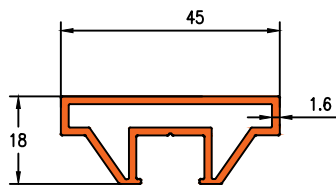

Die No.19743

0.706KG/M

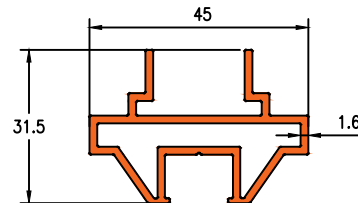

Die No.19744

0.620KG/M

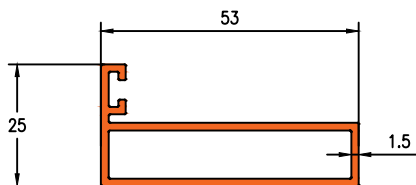

Die No.19745

0.648KG/M

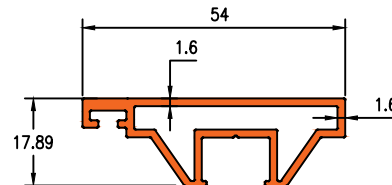

MODULAR



Darshan Extrusions Pvt. Ltd.

Die No.16404

1.052KG/M

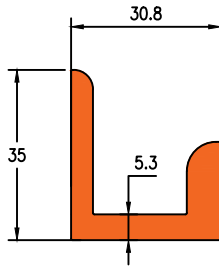

Die No.16408

1.235 KG/M

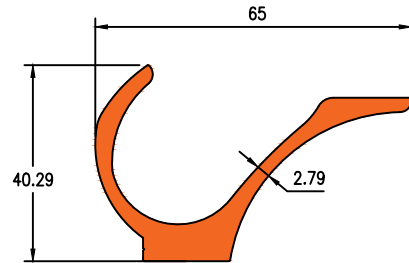

Die No.16409

3.311KG/M

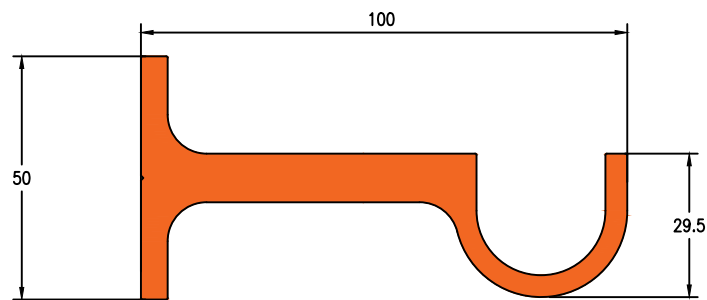

Die No.16414

2.380KG/M

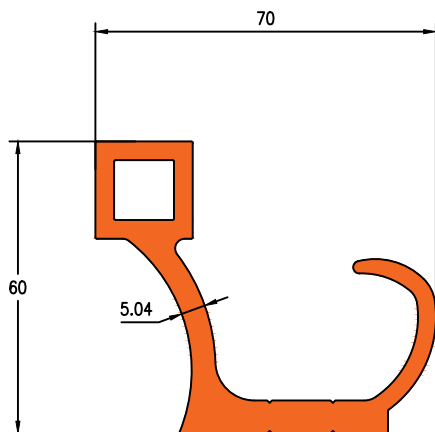

Die No.16407

3.022KG/M

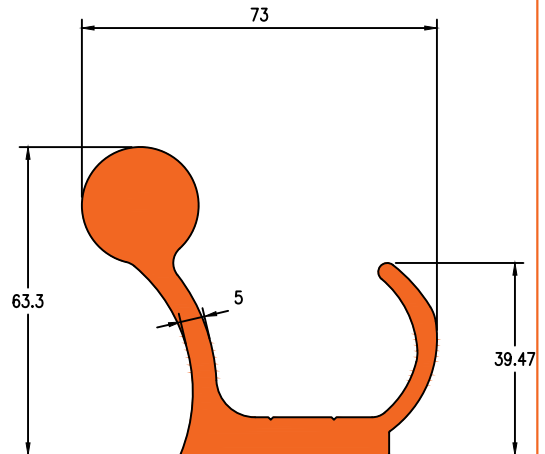

MODULAR



Die No. 19666

0.496 Kg/m

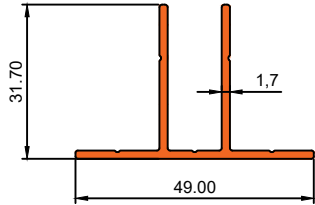

Die No. 19482

2.137 Kg/m

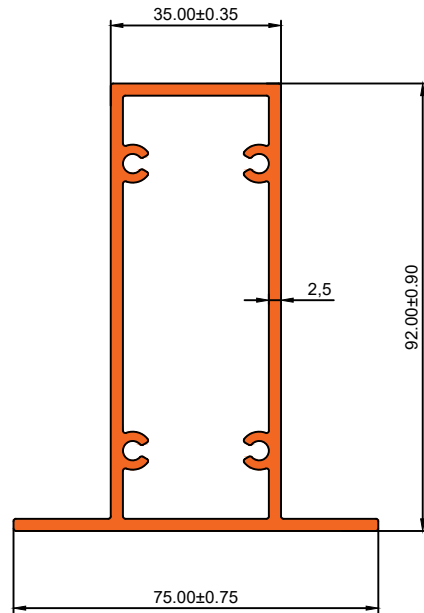

Die No. 19483

1.460 Kg/m

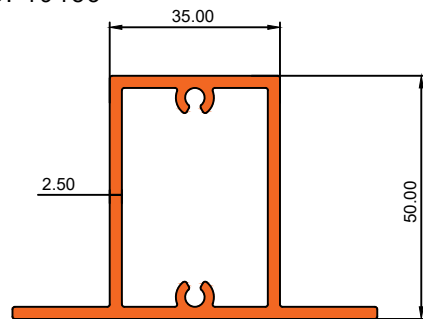

STIFFENER



Darshan Extrusions Pvt. Ltd.

Die No.19943

0.203Kg/m

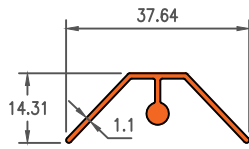

Die No.19944

0.222Kg/m

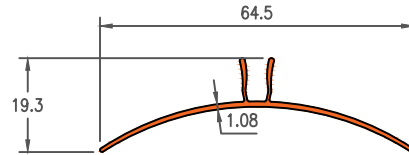

DOME



Darshan Extrusions Pvt. Ltd.

Die No. 1303

0.911Kg/m

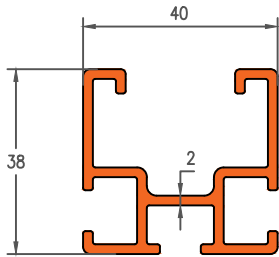

Die No. 19362

0.088Kg/m

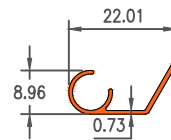

Die No. 19364

0.445Kg/m

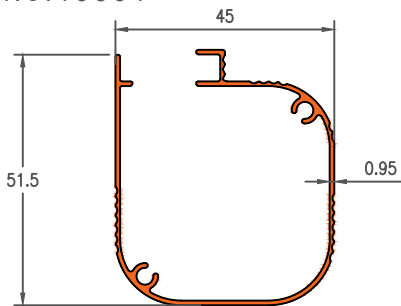

Die No. 19365

0.270Kg/m

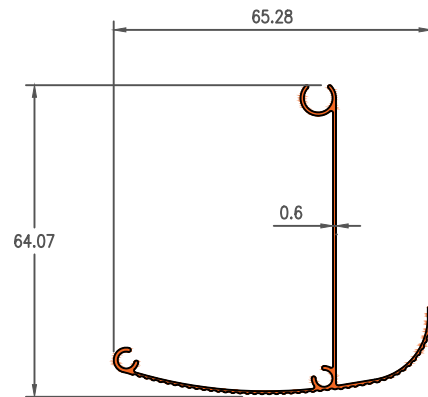

Die No. 19366

0.299Kg/m

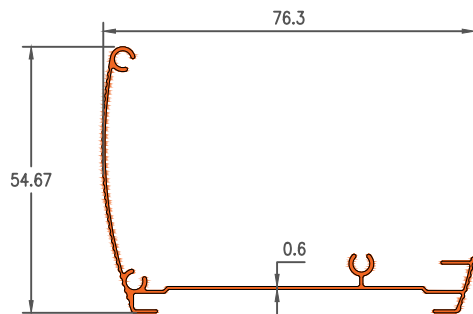

Die No. 19375

0.452Kg/m

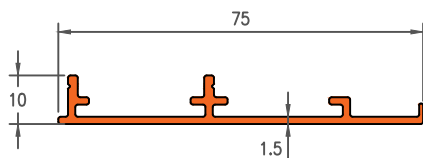

Die No. 19403

0.546Kg/m

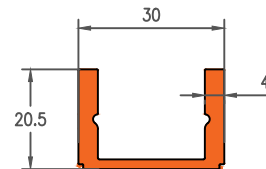

DISPLAY



Darshan Extrusions Pvt. Ltd.

Die No.19402

3.041Kg/m

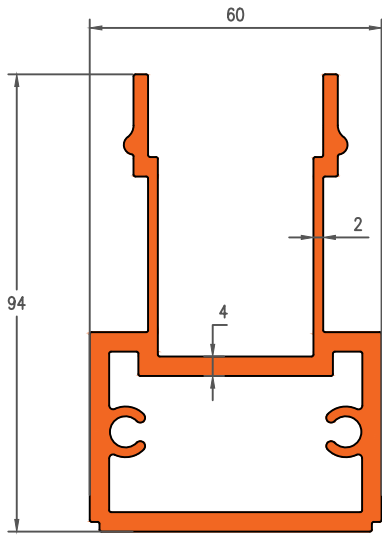

DISPLAY



Darshan Extrusions Pvt. Ltd.

Die No.7069

0.130KG/M

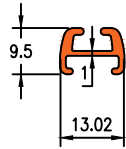

Die No.19711

0.179KG/M

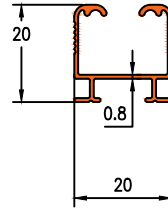

Die No.19473

0.244KG/M
0.212KG/M

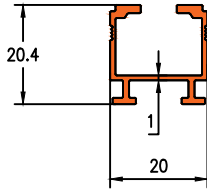

Die No.19406

0.652KG/M

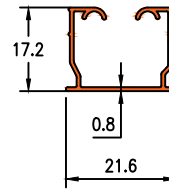

Die No.19712

0.216KG/M

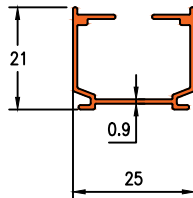

Die No.19484

0.510KG/M

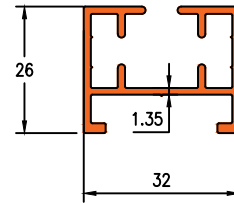

Die No.19369

0.465KG/M

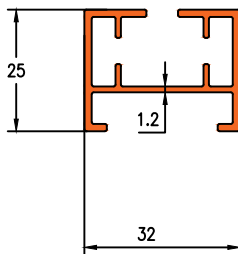

Die No.19826

0.493KG/M

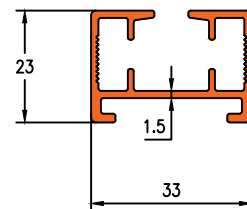

VENETIAN BLINDS



Darshan Extrusions Pvt. Ltd.

Die No.7086

0.469KG/M

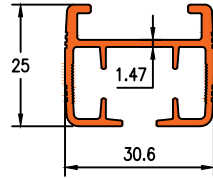

Die No.7068

0.270KG/M

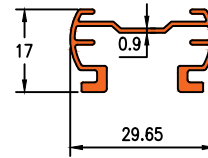

Die No.19405

0.251KG/M

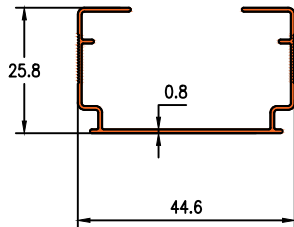

Die No.19921

0.478KG/M

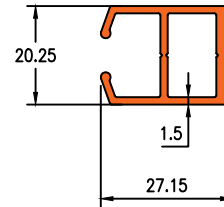

Die No.19918

1.005KG/M

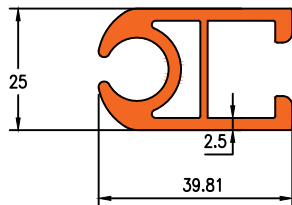

Die No.19964

0.386KG/M

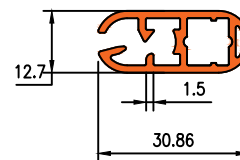

Die No.19715

0.584KG/M

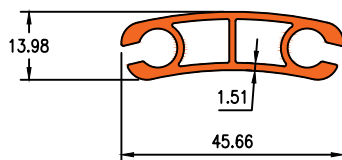

Die No.19919

0.822KG/M

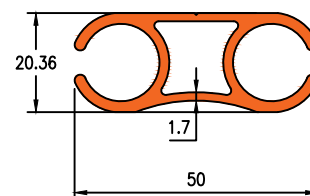

VENETIAN BLINDS



Darshan Extrusions Pvt. Ltd.

Die No.19513

0.265KG/M

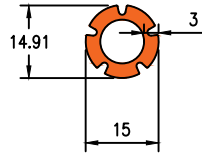

Die No.19408

0.193KG/M

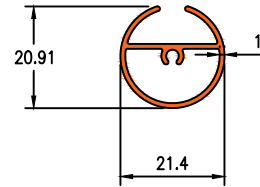

Die No.19028

0.358KG/M

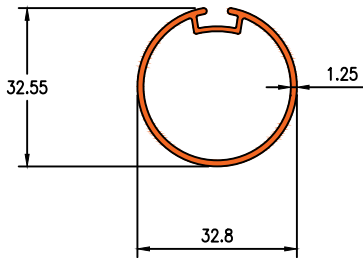

Die No.19963

0.442KG/M

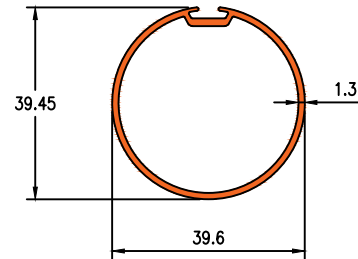

Die No.19029

0.474KG/M

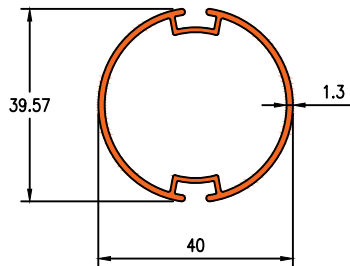

Die No.19504

0.377KG/M

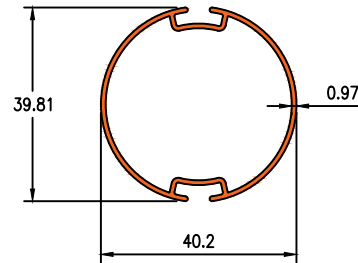

Die No.19507

0.283KG/M

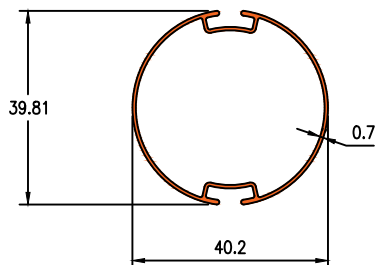

Die No.19682

0.389KG/M

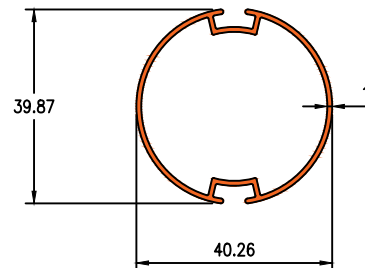

VENETIAN BLINDS



Darshan Extrusions Pvt. Ltd.

Die No.16512

0.430KG/M

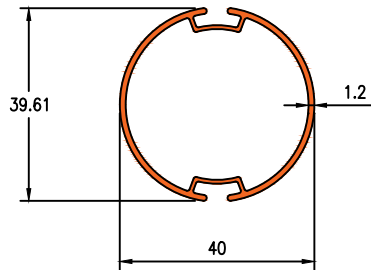

Die No.19681

0.764KG/M

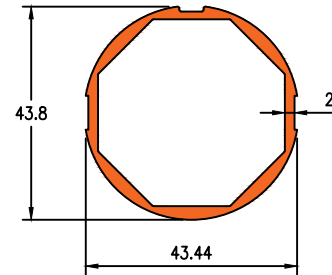

Die No.19993

0.692KG/M

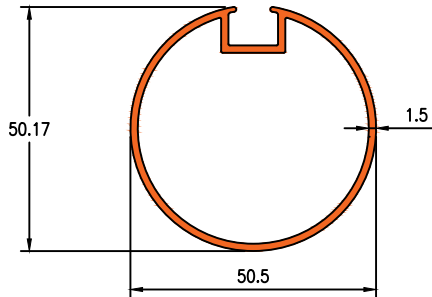

Die No.19697

0.736KG/M

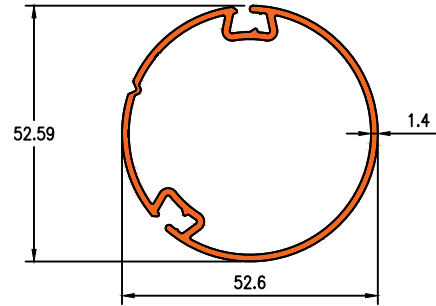

Die No.19632

0.779KG/M

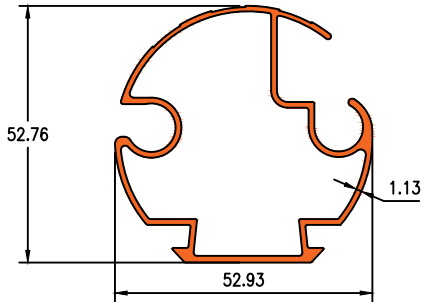

Die No.19516

0.488KG/M

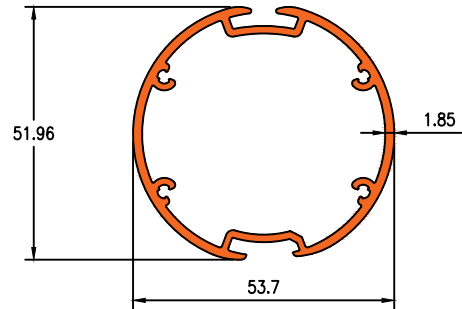

Die No.19633

0.870KG/M

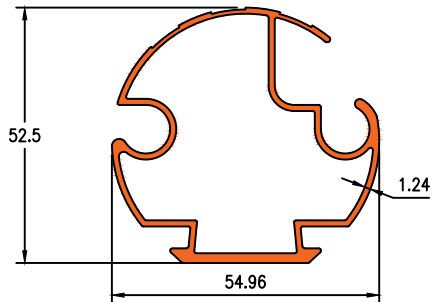

Die No.19505

0.402KG/M

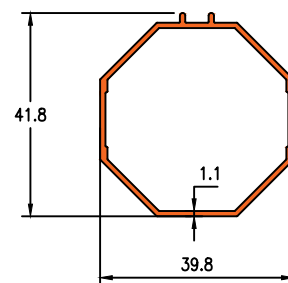

VENETIAN BLINDS



Darshan Extrusions Pvt. Ltd.

Die No. 7067

0.209 KG/M

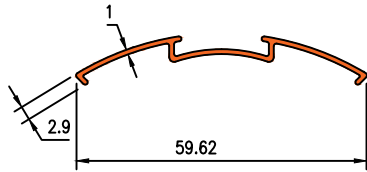

Die No. 7060

0.158 KG/M

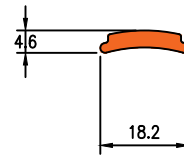

Die No.19404

0.047KG/M

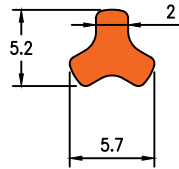

Die No.19514

0.449KG/M

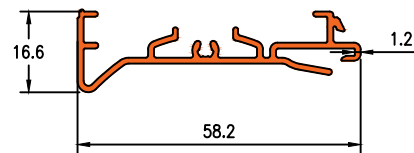

Die No.7070

0.373KG/M

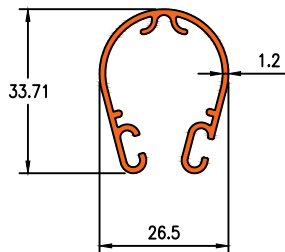

Die No.19515

0.488KG/M

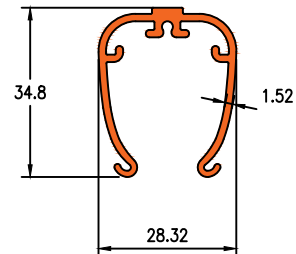

Die No.19707

0.195KG/M

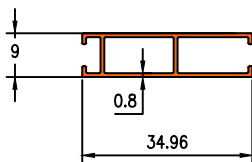

Die No. 7495

0.226KG/M

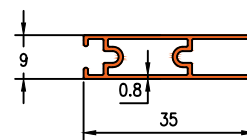

VENETIAN BLINDS



Darshan Extrusions Pvt. Ltd.

Die No.19714

0.681KG/M

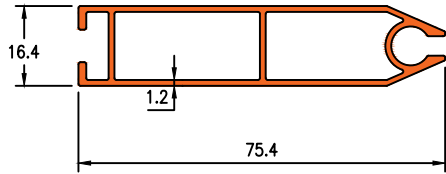

Die No.19506

0.402KG/M

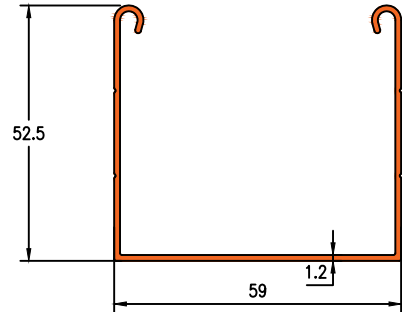

Die No.19032

0.323KG/M

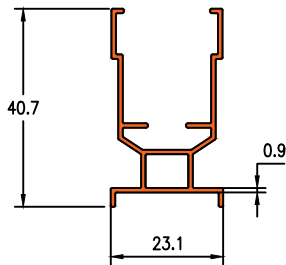

Die No.19033

0.436KG/M

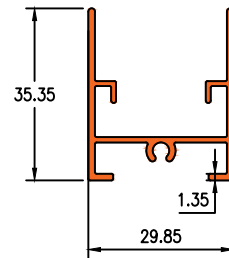

Die No.19034

0.338KG/M

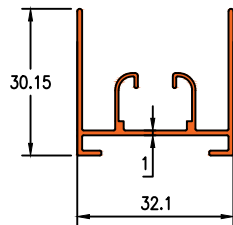

Die No. 19030

0.427 KG/M

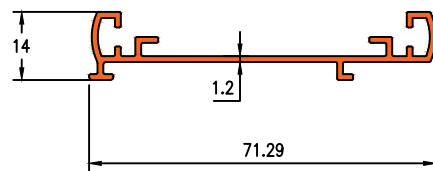

VENETIAN BLINDS



Darshan Extrusions Pvt. Ltd.

Die No.19333

0.529KG/M

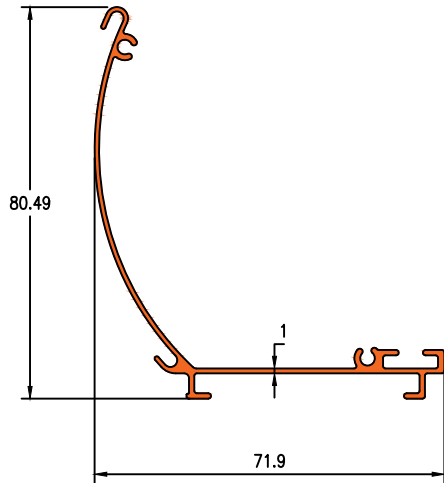

Die No.7124

1.035KG/M

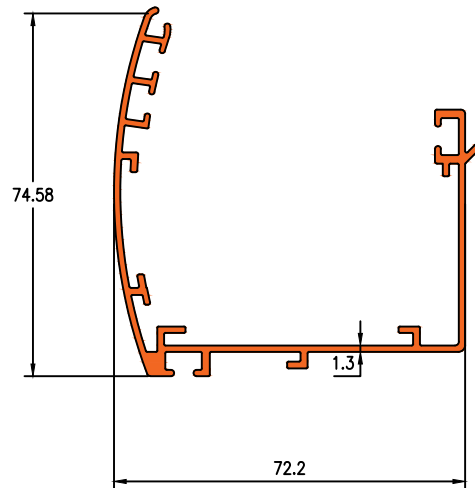

Die No.19517

1.307KG/M

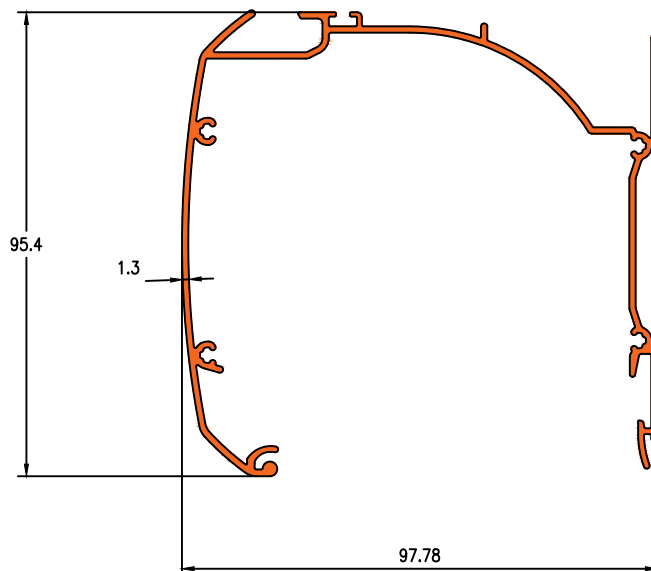

VENETIAN BLINDS



Darshan Extrusions Pvt. Ltd.

Die No.19027

1.453KG/M

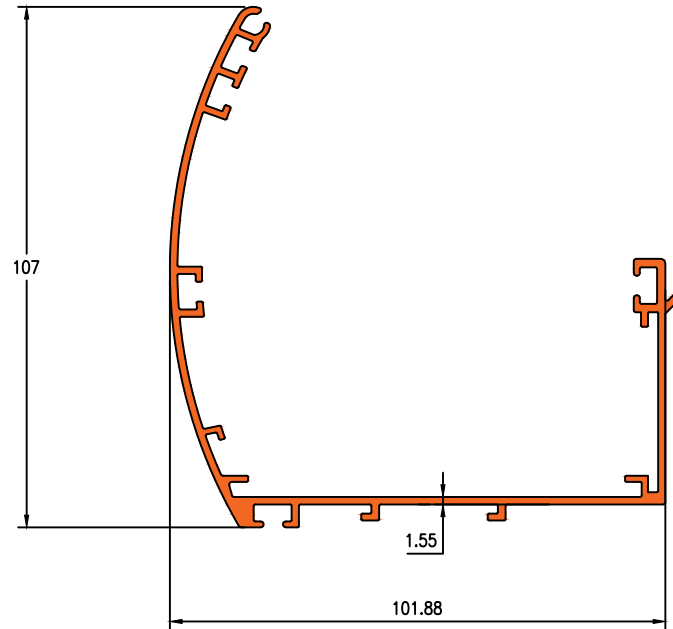

Die No.1265

1.090KG/M

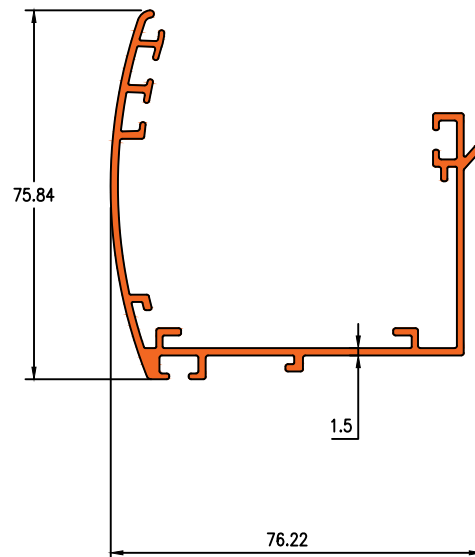

VENETIAN BLINDS



Darshan Extrusions Pvt. Ltd.

Die No.19698

0.578KG/M

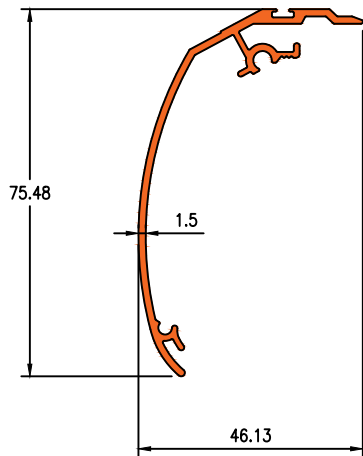

Die No.19680

1.134KG/M

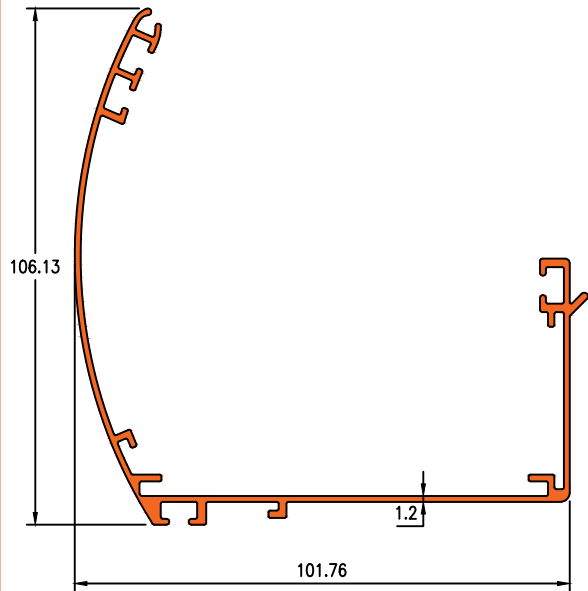

Die No.19679

0.622 KG/M

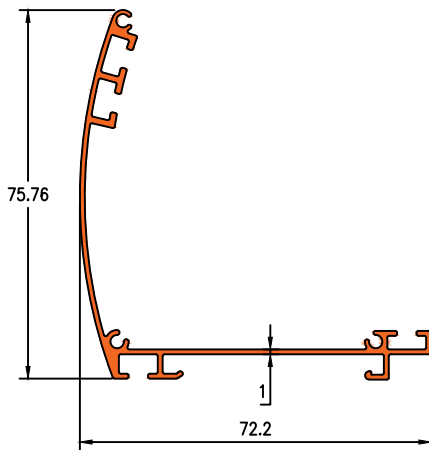

Die No.19987

0.776 KG/M

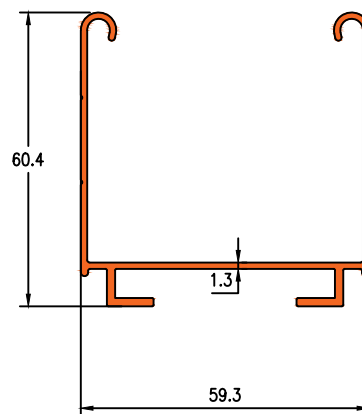

VENETIAN BLINDS



Darshan Extrusions Pvt. Ltd.

Die No.19988

0.406 KG/M

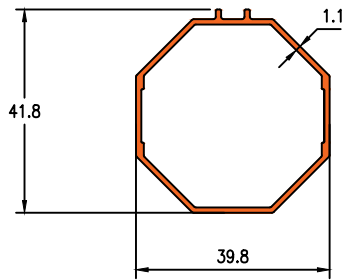

Die No.16503

0.440 KG/M

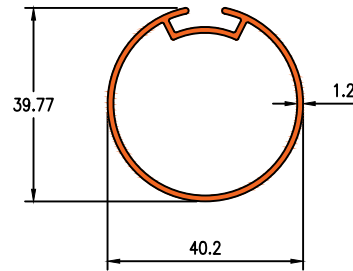

Die No.16504

0.483 KG/M

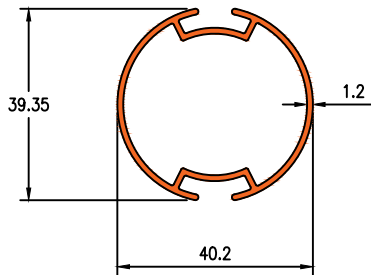

Die No.16579

0.662 KG/M

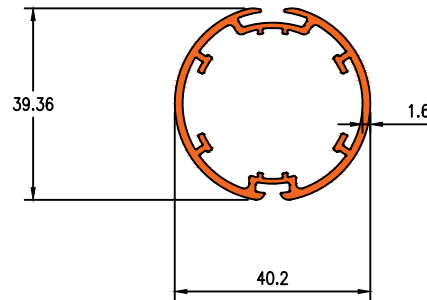

VENETIAN BLINDS



Darshan Extrusions Pvt. Ltd.

Die No. 1284

0.757KG/M

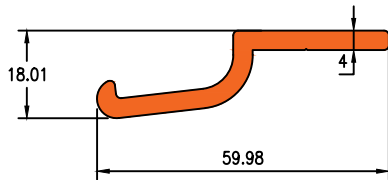

Die No. 19107

0.940KG/M

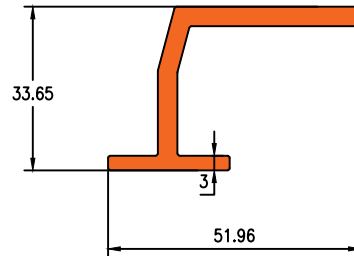

Die No. 1387

0.926KG/M

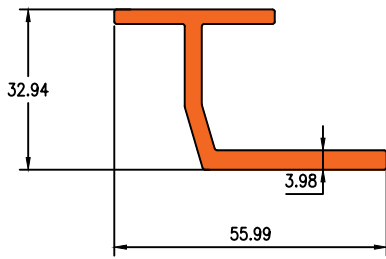

Die No. 7093

1.267KG/M

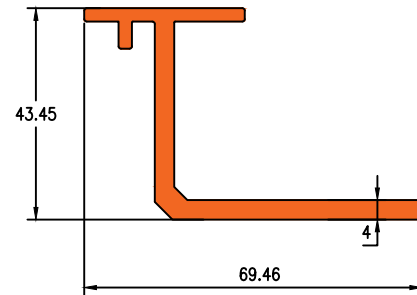

Die No. 7094

1.086KG/M

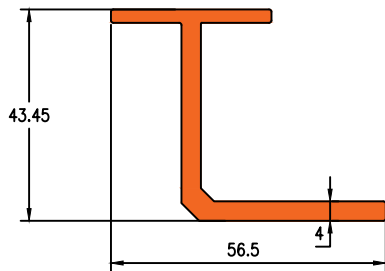

Die No. 7095

0.978KG/M

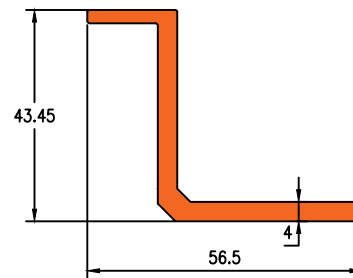

CLADDING



Darshan Extrusions Pvt. Ltd.

Die No.19180

0.253KG/M

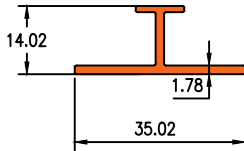

Die No.19343

0.282KG/M

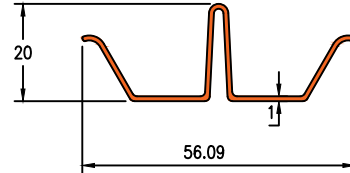

Die No.19353

1.120KG/M

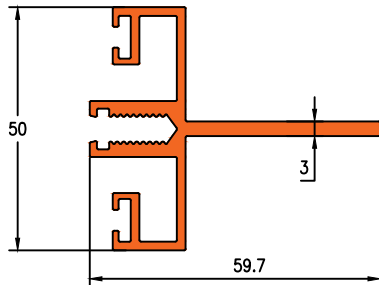

Die No.19354

0.305KG/M

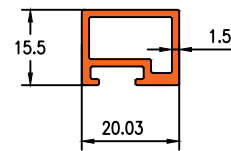

Die No.19355

0.134KG/M

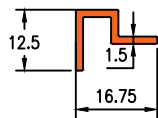

Die No.19356

0.230KG/M

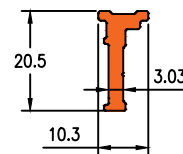

Die No.19903

0.440KG/M

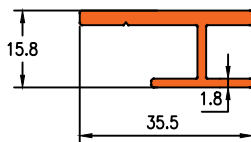

CLADDING



Die No.P60848

2.791KG/M

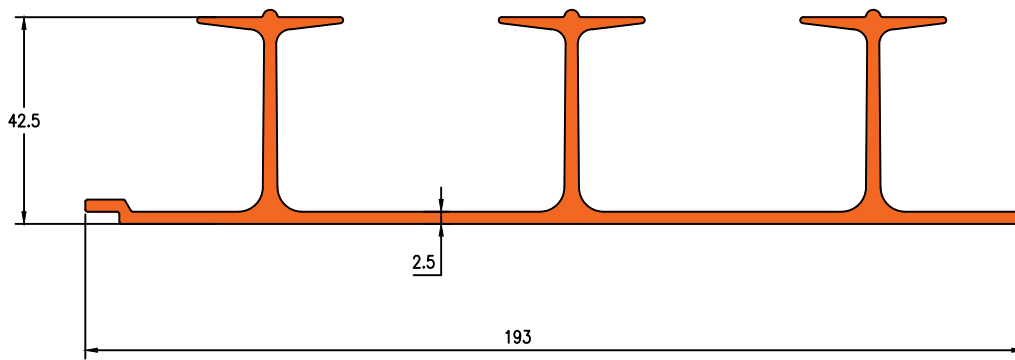

Die No.P61188

0.853KG/M

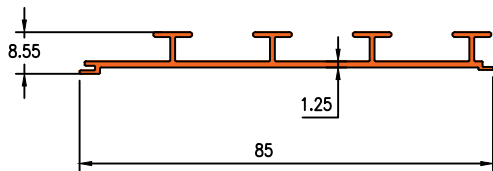

Die No.P61188

0.853KG/M

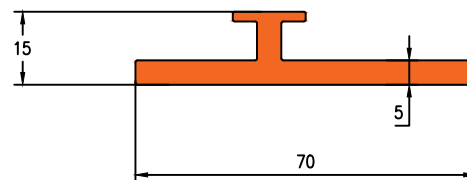

CLADDING



Darshan Extrusions Pvt. Ltd.

Die No.16426

0.841KG/M

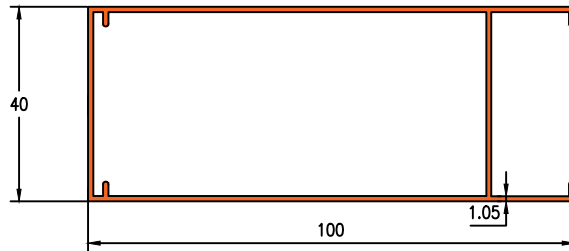

Die No.16545

1.410KG/M

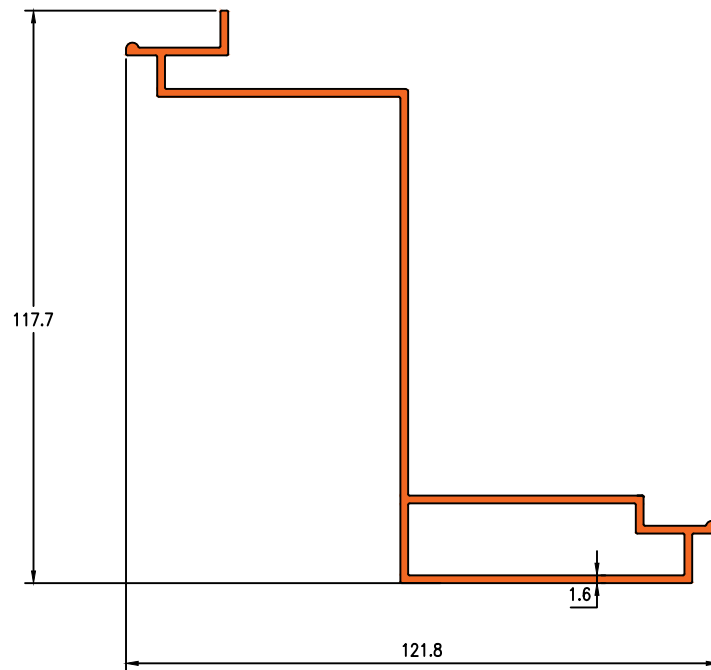

Die No.16435

0.160KG/M

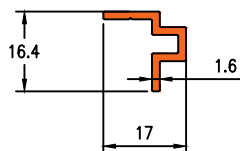

Die No.21181

1.087KG/M

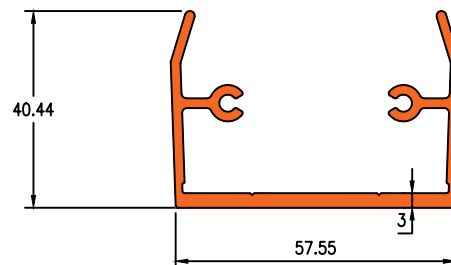

CLADDING



Darshan Extrusions Pvt. Ltd.

Die No.16436

0.142KG/M

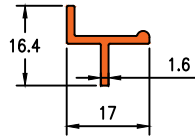

Die No.21180

0.403KG/M

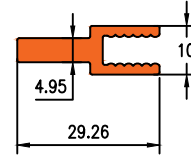

Die No.16544

1.432KG/M

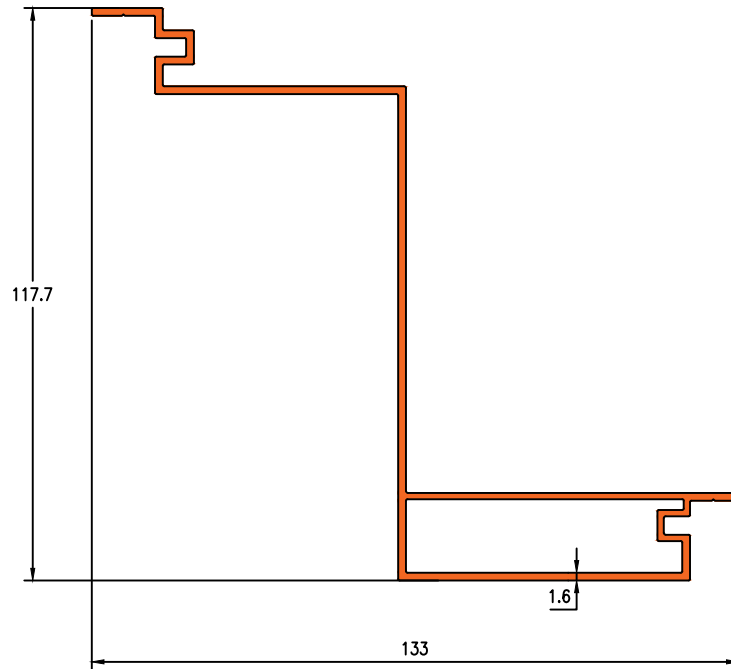

Die No.21192

1.675KG/M

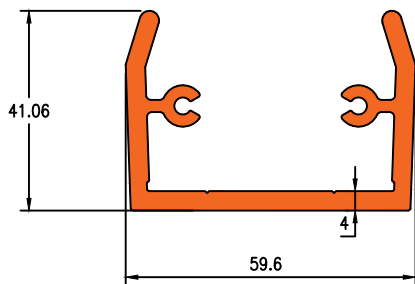

CLADDING



Darshan Extrusions Pvt. Ltd.

Die No.16415

0.209KG/M

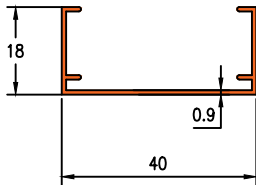

Die No.16416

0.158KG/M

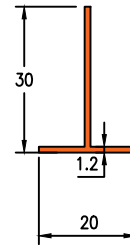

Die No.16417

0.260KG/M

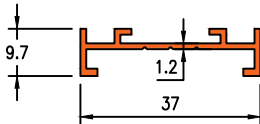

Die No.16419

0.068KG/M

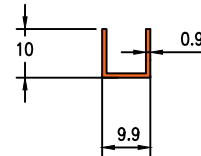

Die No.16429

0.079KG/M

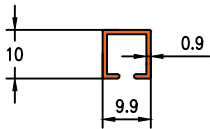

Die No.16430

0.259KG/M

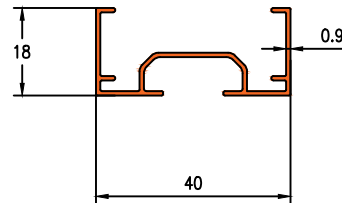

Die No.16434

0.321KG/M

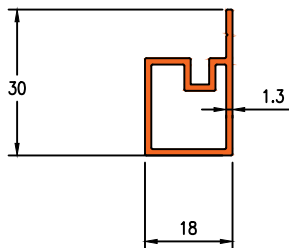

Die No.16420

0.408KG/M

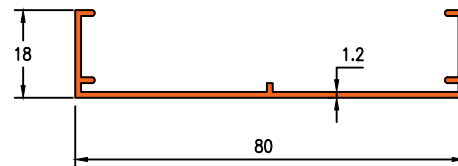

CLADDING



Die No.16421

0.606KG/M

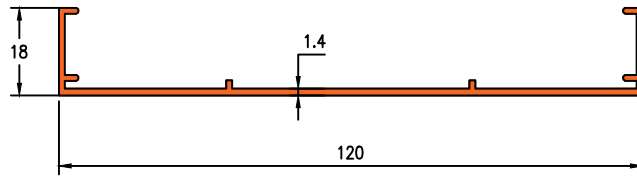

Die No.16428

0.732KG/M

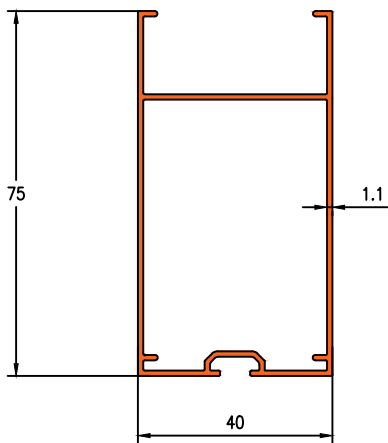

Die No.16425

0.641KG/M

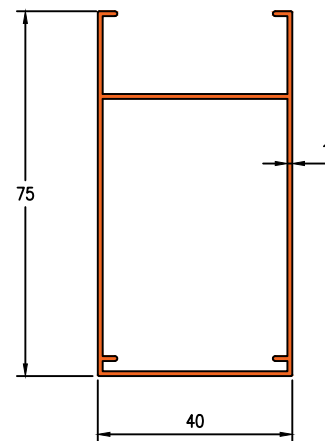

Die No.16418

1.333KG/M

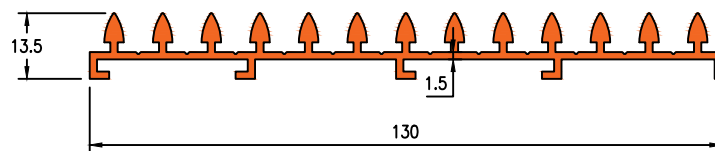

CLADDING



Darshan Extrusions Pvt. Ltd.

Die No.16427

0.881KG/M

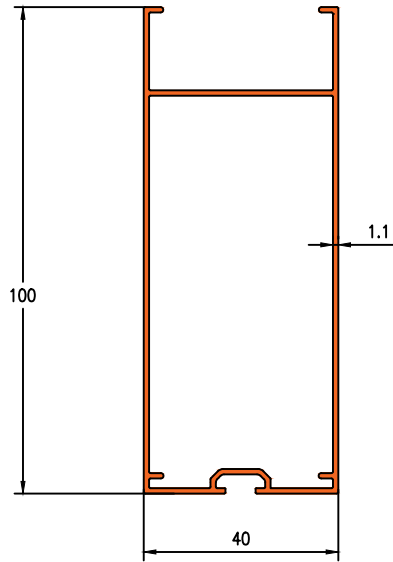

Die No.16431

0.979KG/M

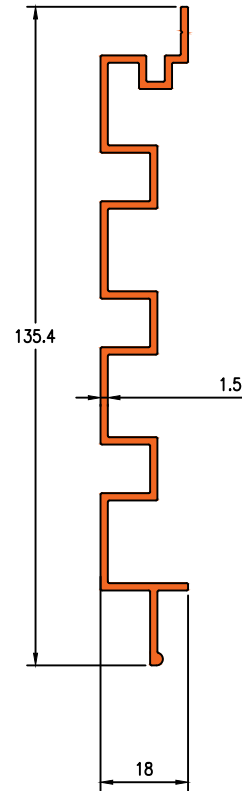

Die No.16432

0.732KG/M

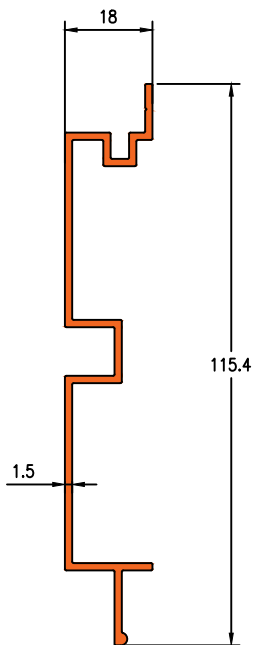

CLADDING



Die No.16433

0.978KG/M

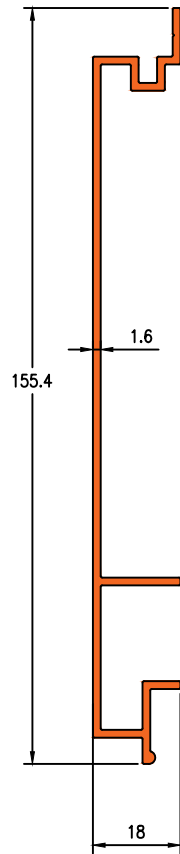

CLADDING



Darshan Extrusions Pvt. Ltd.

Die No. 7054

0.552 Kg/m

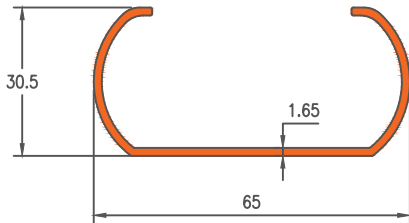

Die No. 7055

0.631 Kg /m

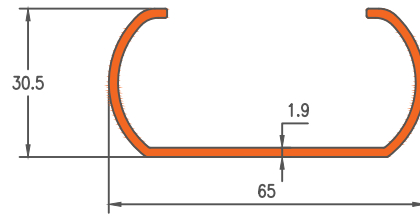

Die No. 7056

0.768Kg/m

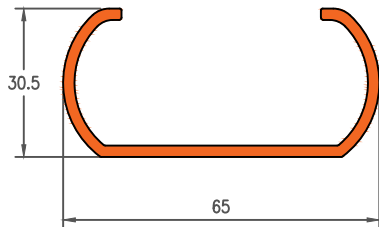

Die No. 7057

0.919 Kg /m

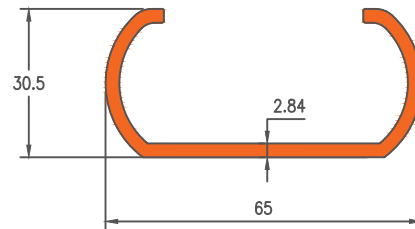

Die No. 16095

0.826Kg/m

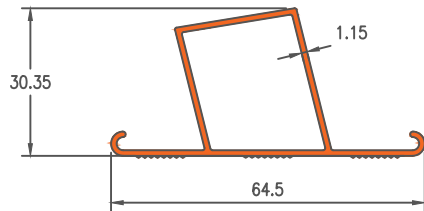

Die No. 1223

0.412Kg/m

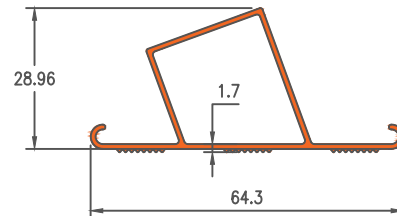

Die No. 1218

0.348Kg/m

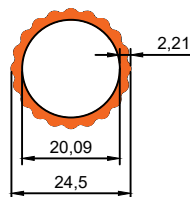

Die No. 1219

2.516Kg/m

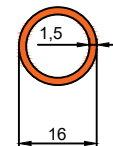

LADDER



Darshan Extrusions Pvt. Ltd.

Die No. 10011

0.270Kg/m

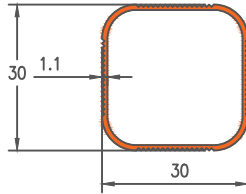

Die No. 10012

0.412Kg/m

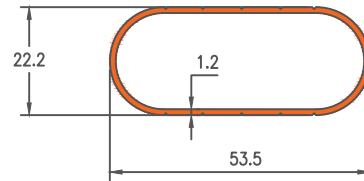

Die No. 10013

0.481Kg/m

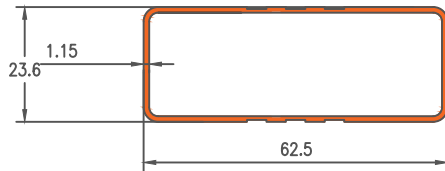

Die No. 10014

0.653 Kg/m

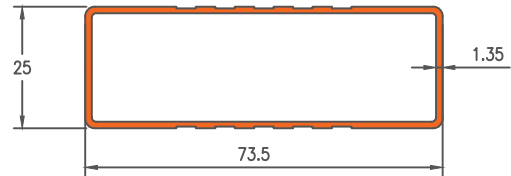

Die No. 10015

0.400Kg/m

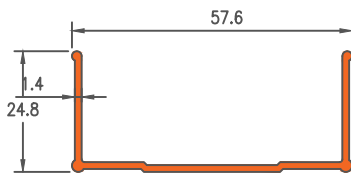

Die No. 10016

0.420Kg/m

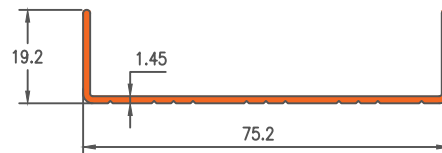

Die No. 10017

0.424Kg/m

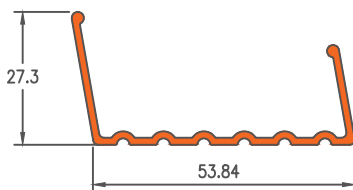

Die No. 10018

0.488Kg/m

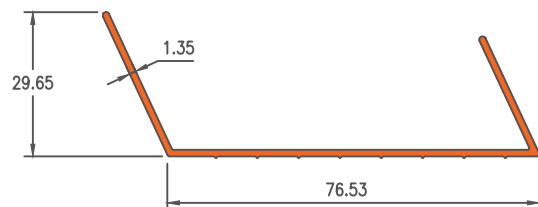

LADDER



Darshan Extrusions Pvt. Ltd.

Die No. 10019

0.824Kg/m

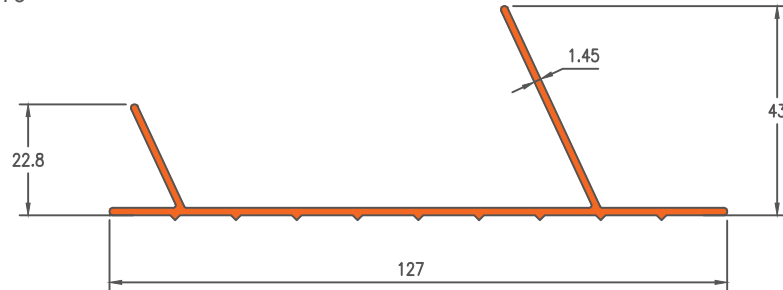

Die No. 19049

0.571Kg/m

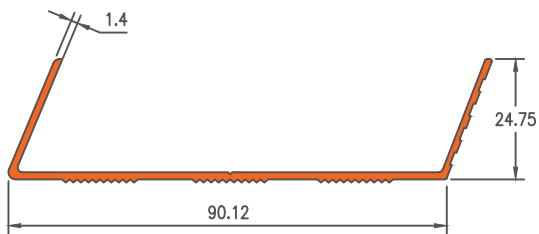

Die No. 19050

0.608Kg/m

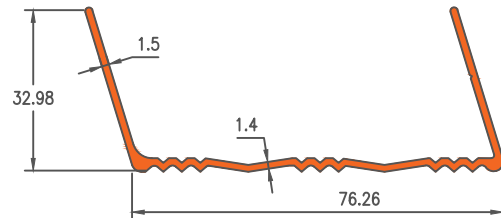

Die No. 19046

0.410Kg/m

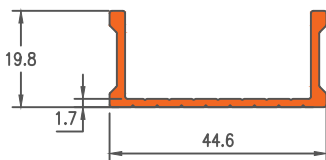

Die No. 19048

0.454Kg/m

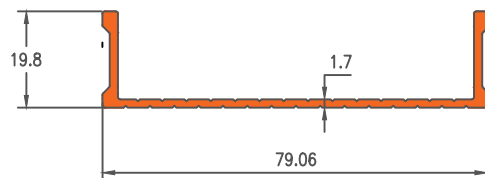

Die No. 16094

0.457Kg/m

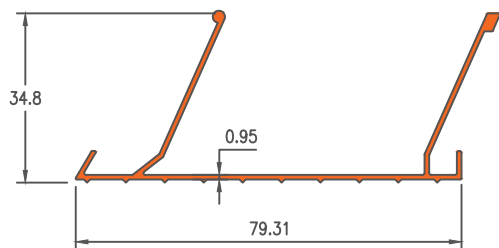

Die No. 7107

1.032Kg/m

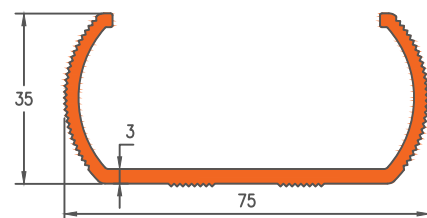

LADDER



Darshan Extrusions Pvt. Ltd.

Die No. 19129

0.895Kg/m

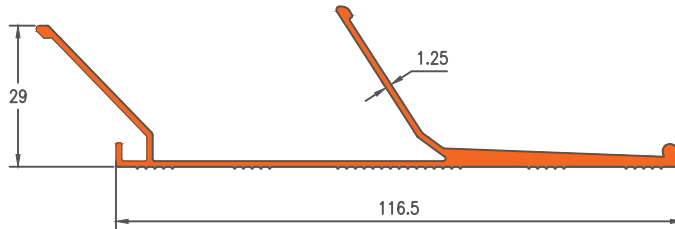

Die No. 16001

1.568Kg/m

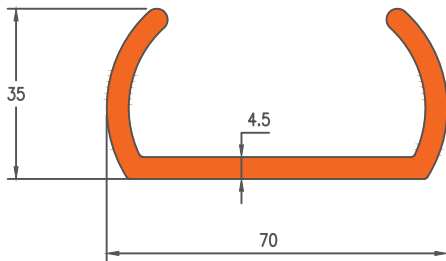

Die No. 16002

1.227Kg/m

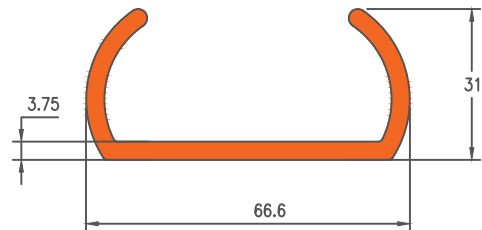

Die No. 19442

0.902Kg/m

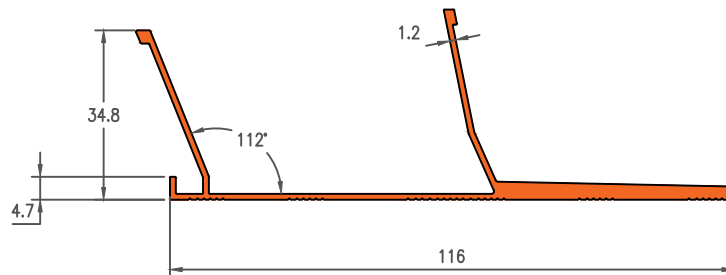

Die No. 19447

0.359Kg/m

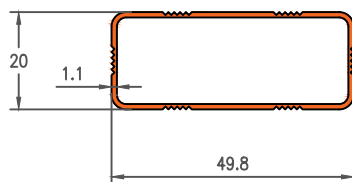

Die No. 19809

0.249Kg/m

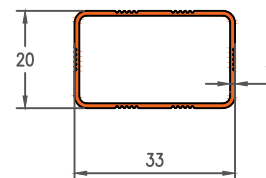

LADDER



Darshan Extrusions Pvt. Ltd.

Die No. 19420

0.431 Kg/m

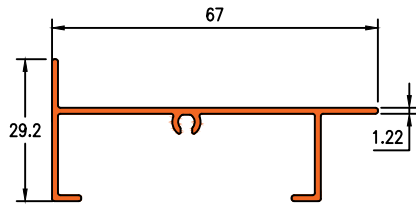

Die No. 16143

0.652 Kg/m

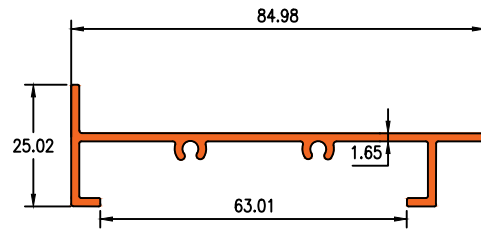

Die No. 19749

0.436 Kg/m

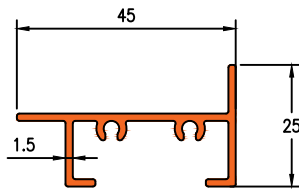

Die No. 16144

0.744 Kg/m

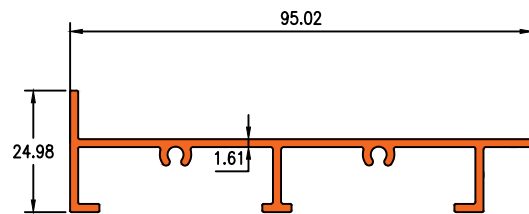

Die No. 16145

0.942 Kg/m

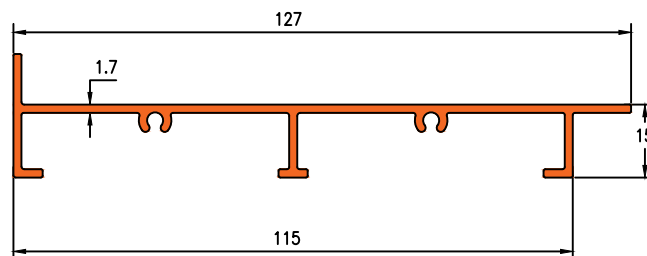

Die No. 16018

0.568 Kg/m

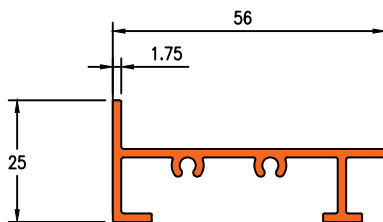

Die No. 16017

0.450 Kg/m

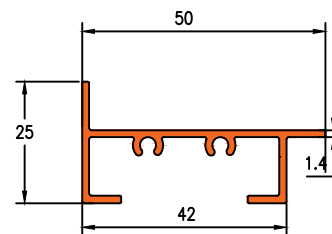

SUBFRAME



Darshan Extrusions Pvt. Ltd.

Die No. 16019

0.590 Kg/m

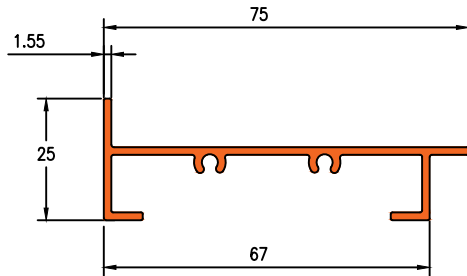

Die No. 16020

0.795 Kg/m

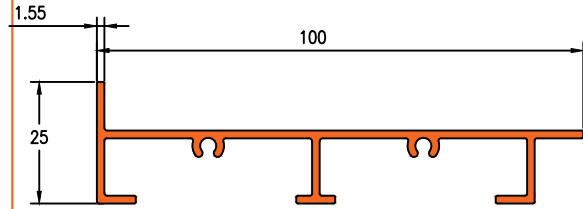

Die No. 7039

0.959 Kg/m

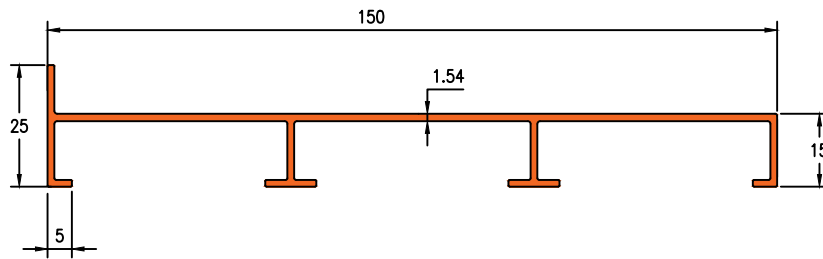

Die No. 19394

1.136 Kg/m

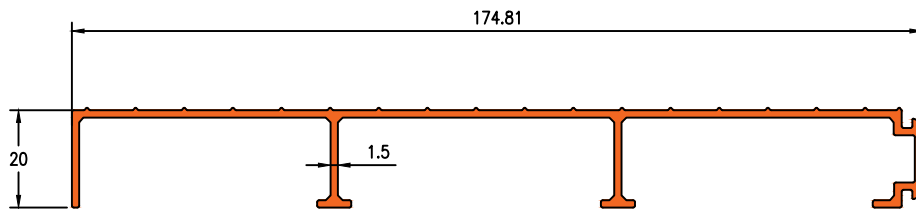

Die No. 23106

1.687 Kg/m

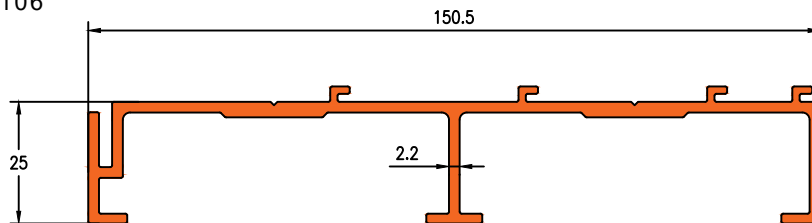

SUBFRAME



Die No. 23107

0.265 Kg/m

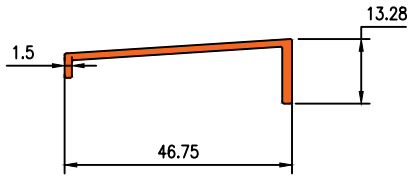

SUBFRAME



Darshan Extrusions Pvt. Ltd.

Die No.19378

0.391Kg/m

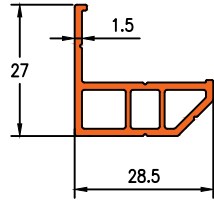

Die No.19378A

0.306Kg/m

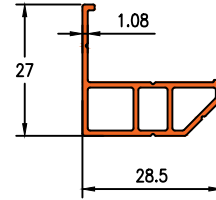

Die No.19379

0.111Kg/m

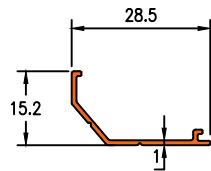



Die No.21093

0.615Kg/m

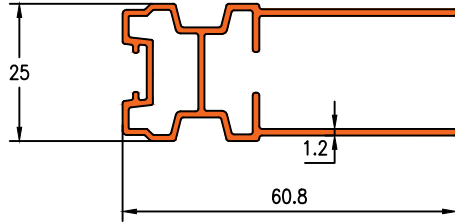

Die No.21090

0.517Kg/m

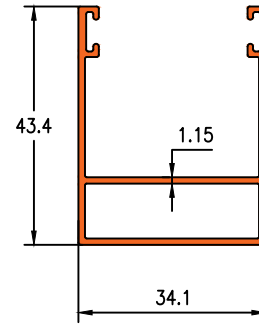

Die No.21091

0.443Kg/m

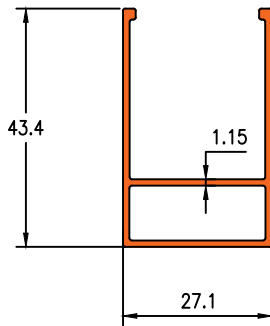

Die No.21092

0.367Kg/m

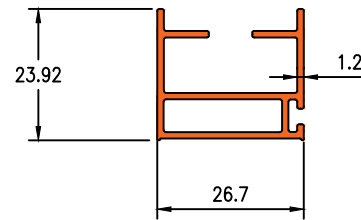



Die No. 19667

0.484 Kg/m

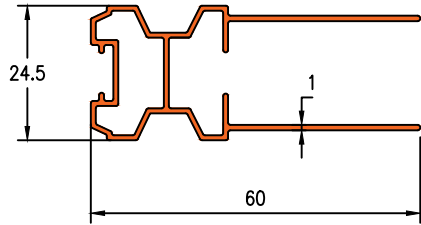

Die No. 19828

0.426 Kg/m

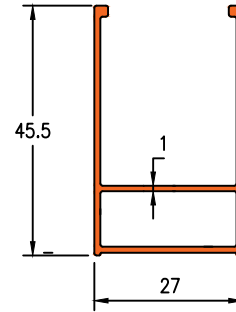

Die No. 19829

0.314 Kg/m

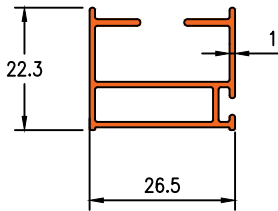



Die No. 21099

0.511 Kg/m

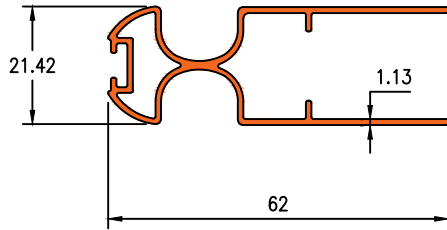

Die No. 21100

0.366 Kg/m

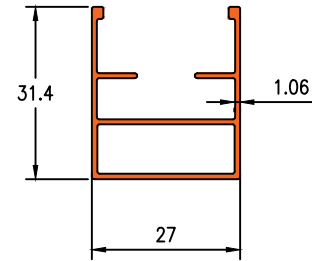

Die No. 21101

0.340 Kg/m

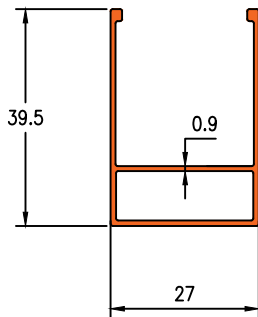



Die No. 19346

0.339 Kg/m

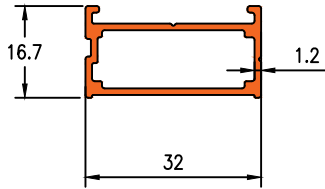

Die No. 19345

0.405 Kg/m

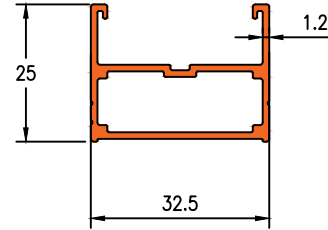



Darshan Extrusions Pvt. Ltd.

Die No. 19036

0.237KG/M

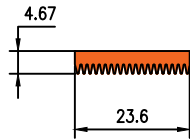

Die No. 19037

2.133KG/M

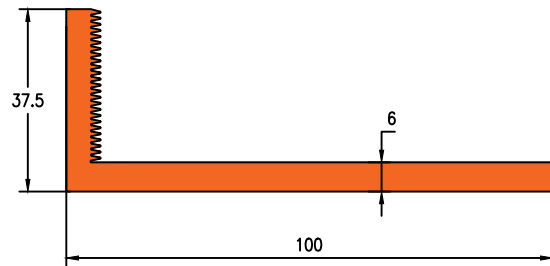

Die No. 11101

5.067KG/M

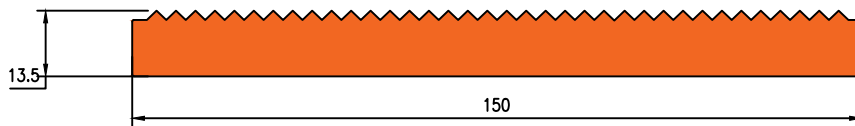

Die No. 19038

2.083KG/M

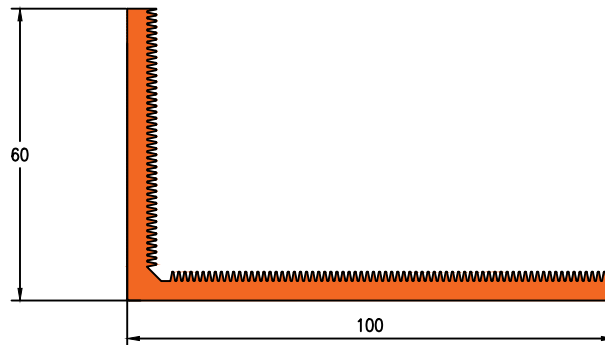

Die No. 19127

0.508KG/M

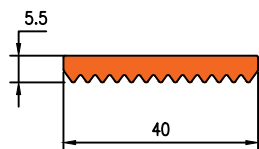

Die No. 1356

1.539KG/M

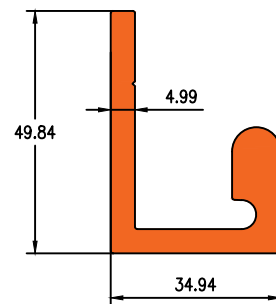

ARCHITECTURAL



Darshan Extrusions Pvt. Ltd.

Die No. 19060

0.608KG/M

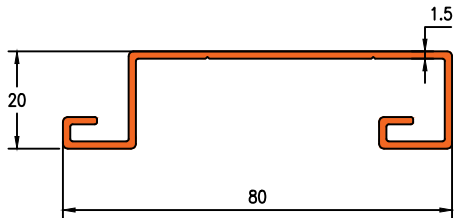

Die No. 1285

0.641KG/M

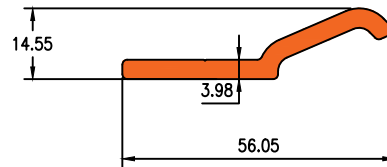

Die No. 1466

0.605KG/M

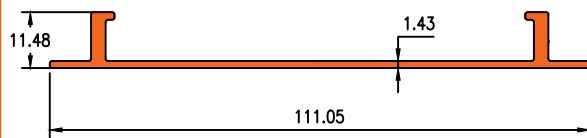

Die No. 401

0.120KG/M

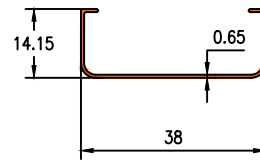

Die No. 19126

3.158KG/M

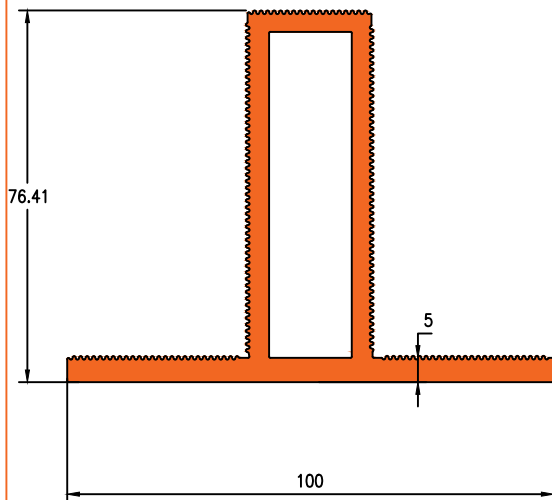

Die No. 1426

1.267KG/M

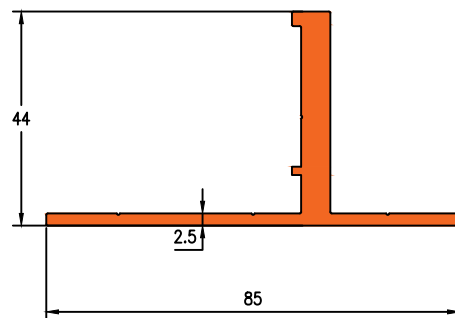

ARCHITECTURAL



Darshan Extrusions Pvt. Ltd.

Die No. 19061

0.829KG/M

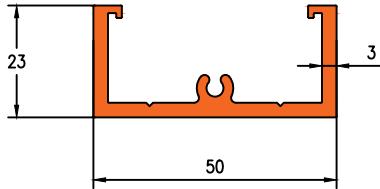

Die No. 19065

1.144KG/M

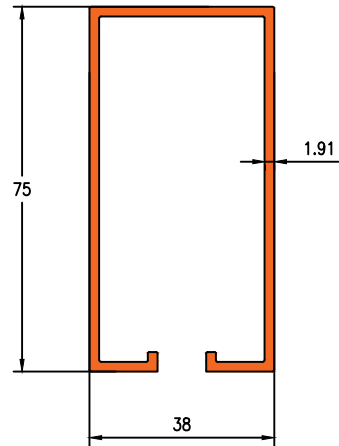

Die No. 7110

0.232KG/M

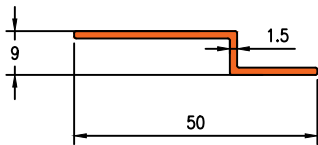

Die No. 19128

0.163KG/M

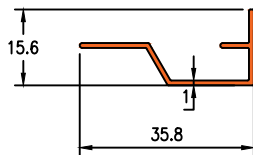

Die No. 27022

0.632KG/M

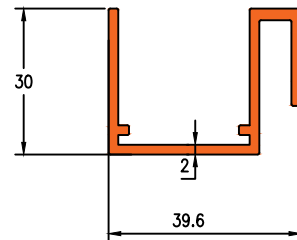

Die No. 19132

0.766KG/M

0.669KG/M

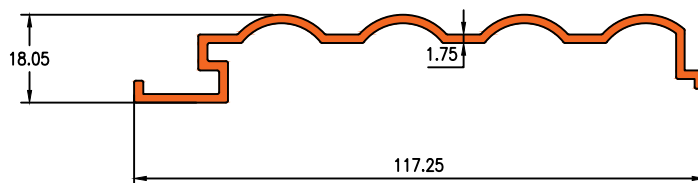

ARCHITECTURAL



Darshan Extrusions Pvt. Ltd.

Die No. 27020

0.771KG/M

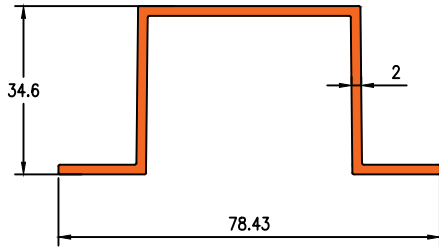

Die No. 27023

0.671KG/M

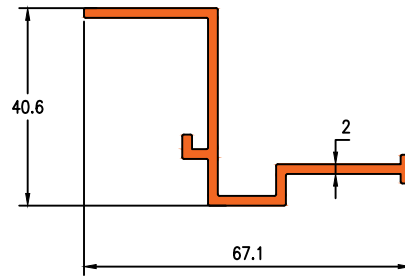

Die No. 27021

1.634KG/M

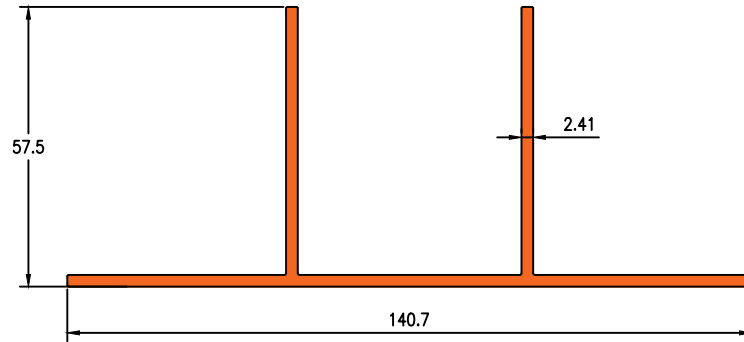

Die No. 7091

1.380KG/M

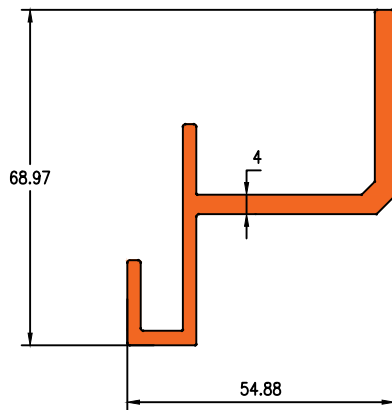

Die No. 27024

0.782KG/M

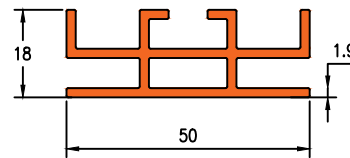

Die No. 7092

1.435KG/M

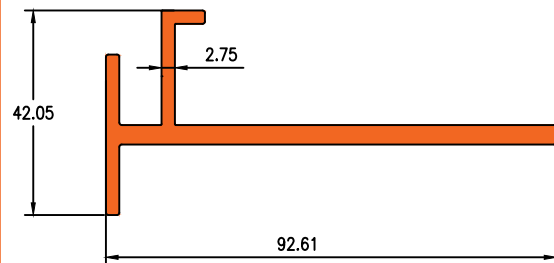

ARCHITECTURAL



Darshan Extrusions Pvt. Ltd.

Die No. 19164

1.060KG/M

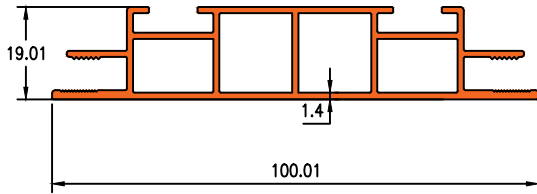

Die No. 19170

1.342KG/M

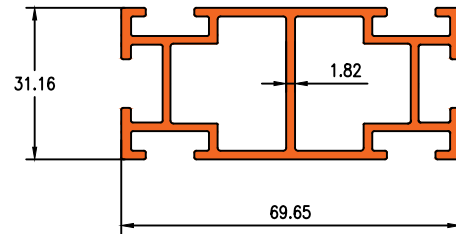

Die No. 19171

0.383KG/M

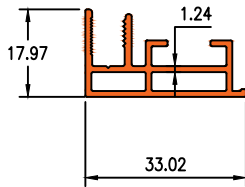

Die No. 19172

0.422KG/M

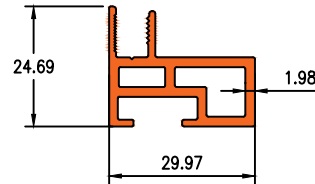

Die No. 19175

0.432KG/M

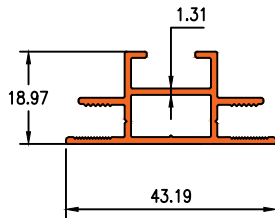

Die No. PD-101

0.779KG/M

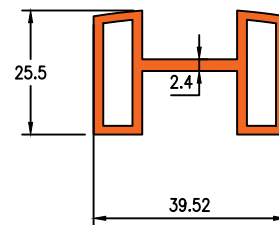

Die No. 19176

1.536KG/M

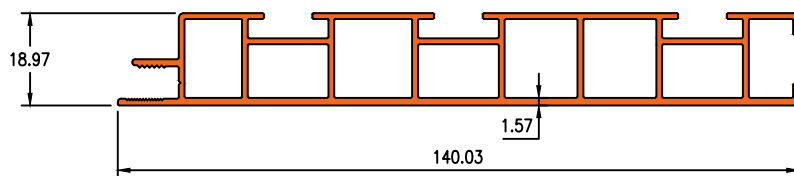



Darshan Extrusions Pvt. Ltd.

Die No. 19610

3.554KG/M

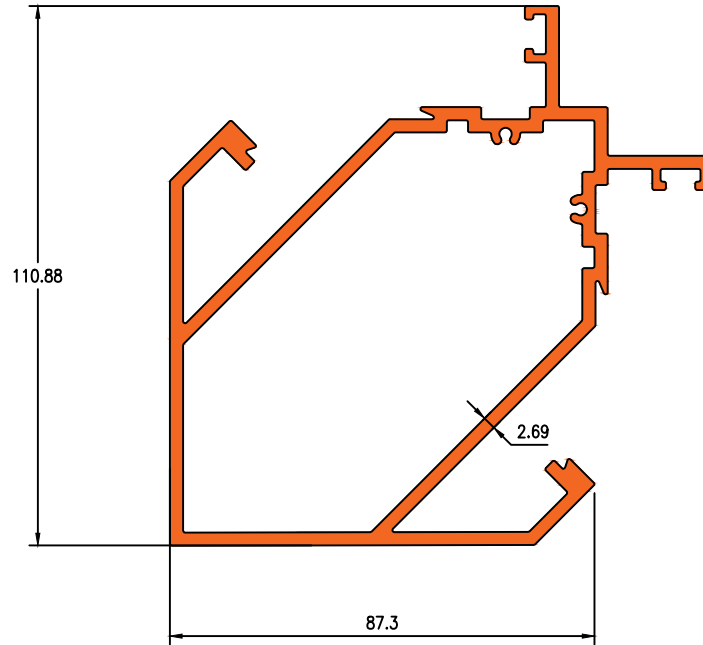

Die No. PD-102

0.917KG/M

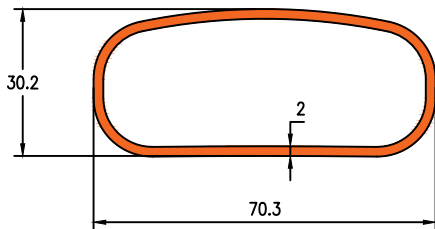

Die No. 19827

1.668KG/M

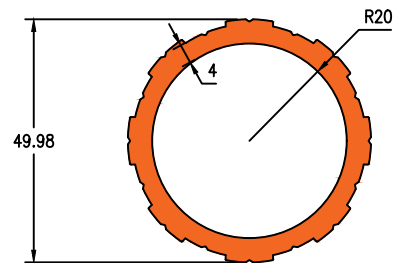

Die No. 11320

0.197KG/M

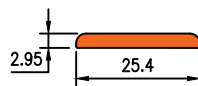

Die No. 21001

0.253 KG/M

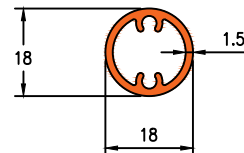

ARCHITECTURAL



Darshan Extrusions Pvt. Ltd.

Die No. 16011

0.307KG/M

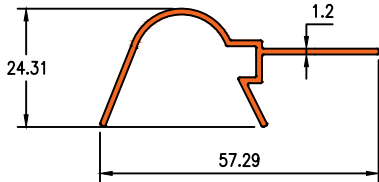

Die No. 16016

0.071KG/M

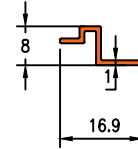

Die No. 19476

0.555 KG/M

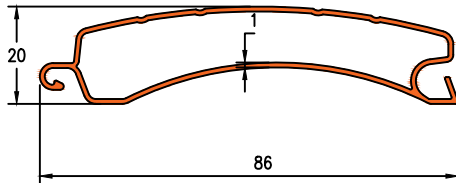

Die No. 7050

0.306KG/M

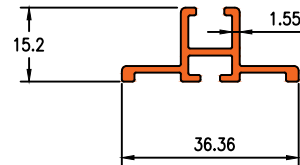

Die No. 1468

0.191KG/M

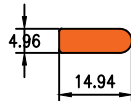

Die No. 1461

0.112KG/M

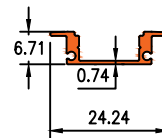

Die No. 1410

0.248KG/M

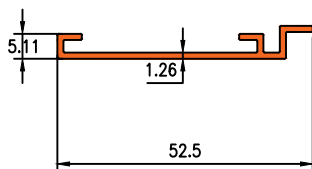

Die No. 1453

0.264KG/M

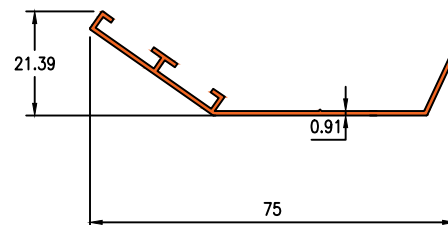

ARCHITECTURAL



Darshan Extrusions Pvt. Ltd.

Die No. 1360

1.527KG/M

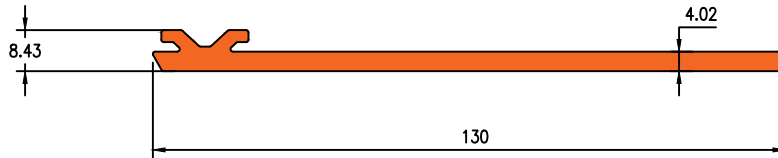

Die No. 1361

1.088KG/M

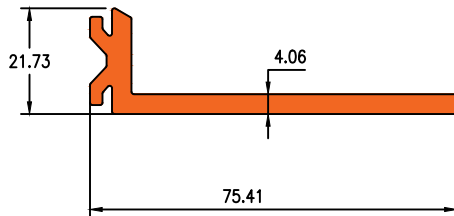

Die No. 1455

0.828KG/M

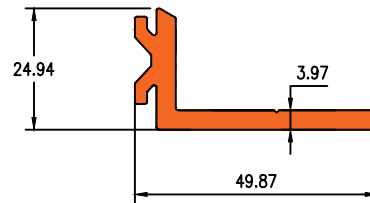

Die No. 1359

1.663KG/M

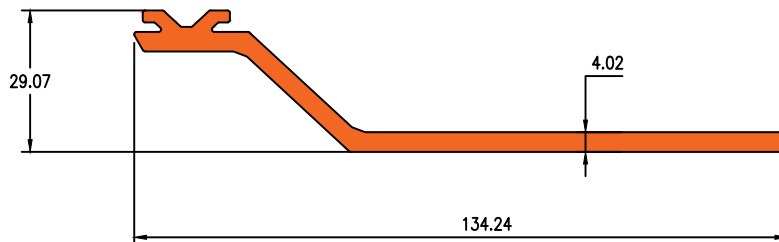

Die No. 1456

1.869KG/M

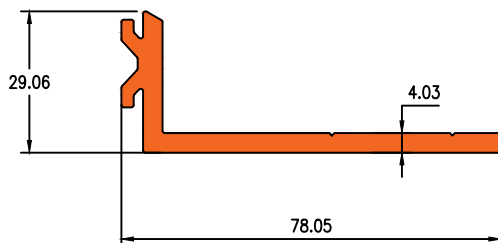

Die No. 1357

1.053KG/M

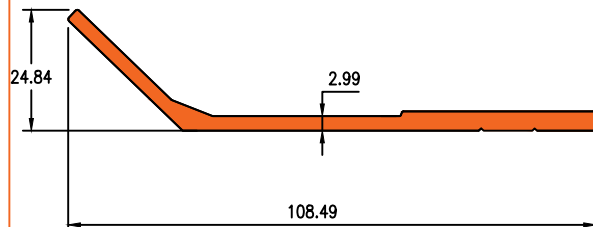

BRACKETS



Darshan Extrusions Pvt. Ltd.

Die No. 1370

0.164KG/M

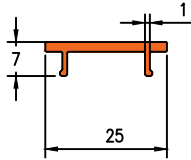

Die No. 1369

0.917KG/M

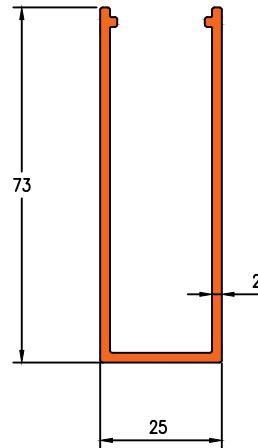

Die No. 1300

0.504KG/M

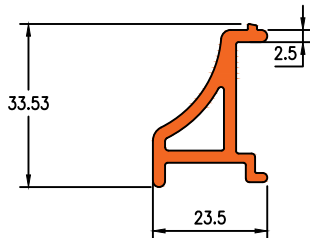

Die No. 1324

0.823KG/M

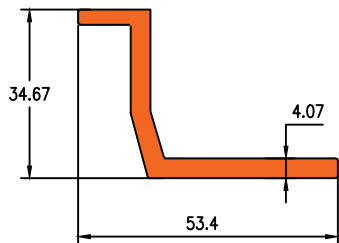

Die No. 1323

0.827KG/M

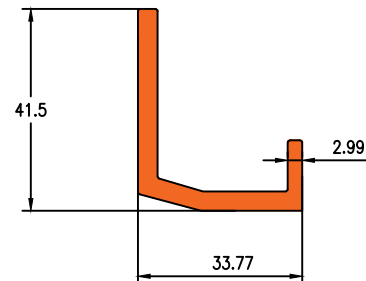

Die No. 1358

1.887KG/M

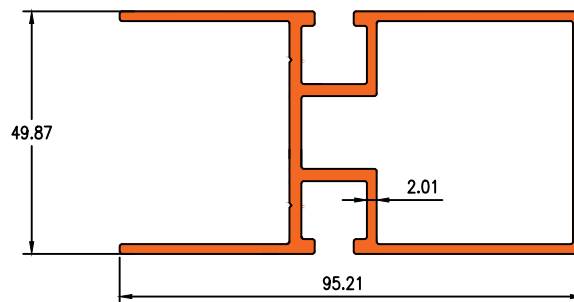



Darshan Extrusions Pvt. Ltd.

Die No. 1424

1.577KG/M

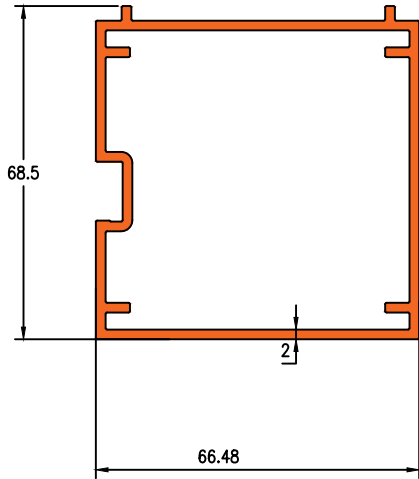

Die No. 1423

0.541KG/M

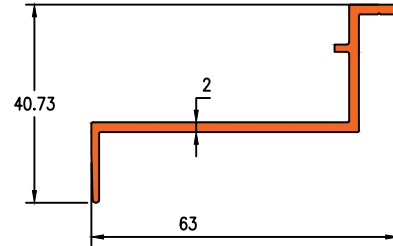

Die No. 1406

0.997 KG/M

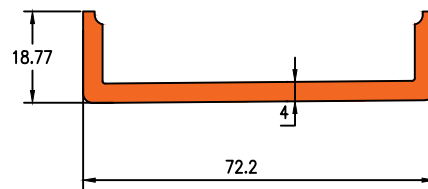

Die No. 1430

0.476KG/M

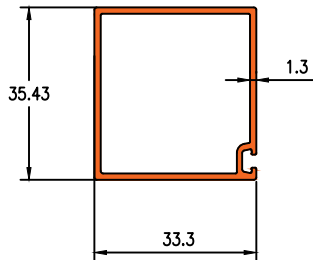

Die No. 1429

1.599 KG/M

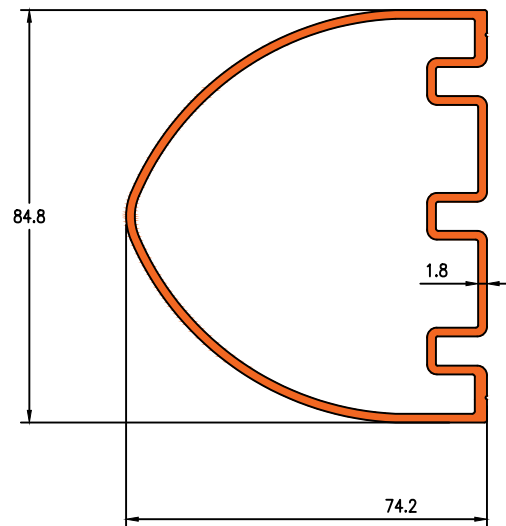

Die No. 1233

1.060KG/M

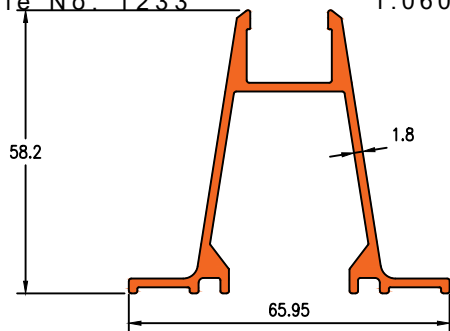



Darshan Extrusions Pvt. Ltd.

Die No. 1234

0.623KG/M

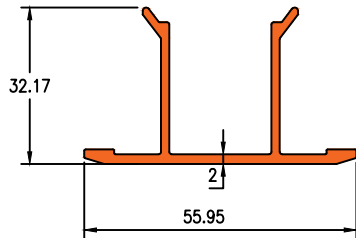

Die No. 1450

0.556KG/M

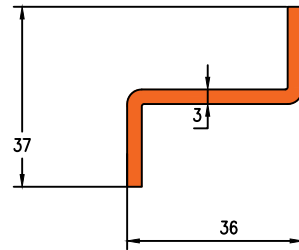

Die No. 1448

1.275KG/M

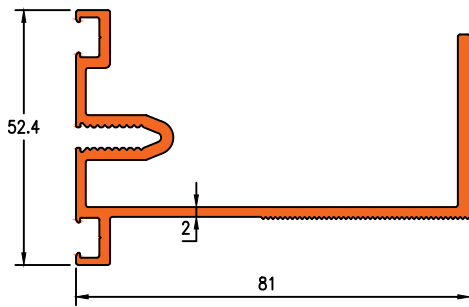

Die No. 1472

0.215KG/M

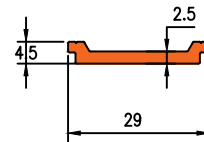

Die No. 1474

1.459KG/M

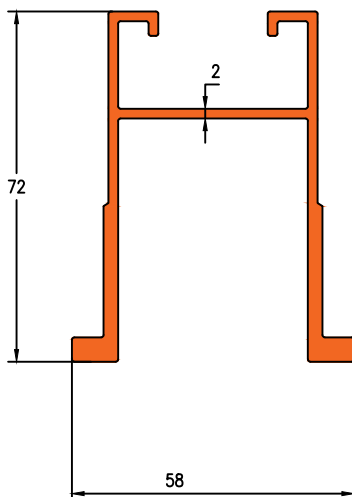

Die No. 1327

0.393KG/M

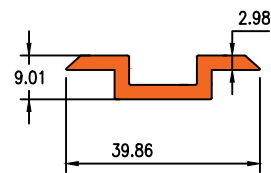

Die No. 1375

1.642KG/M

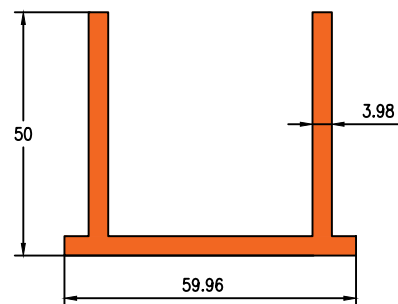

ARCHITECUTRAL



Die No. 19146

1.506 KG/M

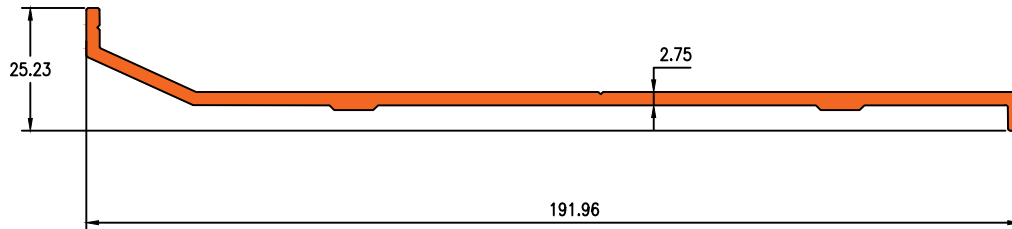

Die No. 19147

1.601 KG/M

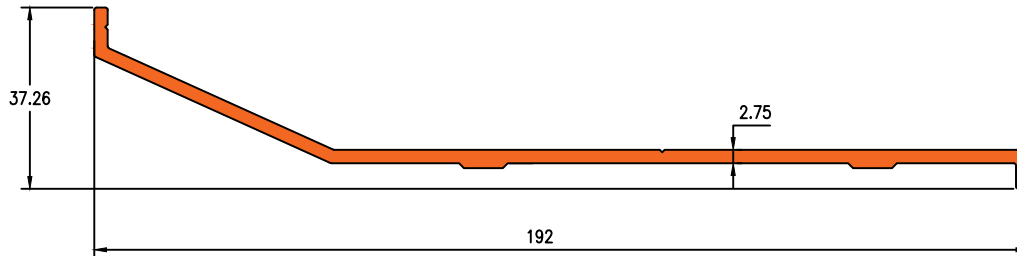



Darshan Extrusions Pvt. Ltd.

Die No.1287

0.299KG/M

Die No.1281

0.579KG/M

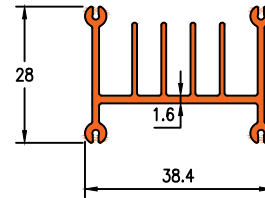
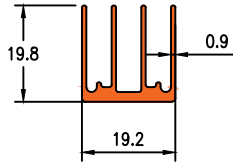

Die No.1288

1.164KG/M

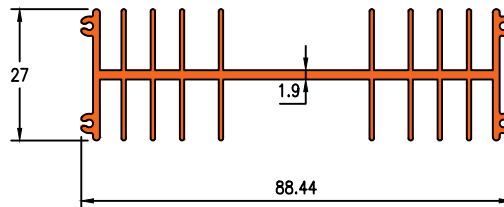

Die No.19002

1.966KG/M

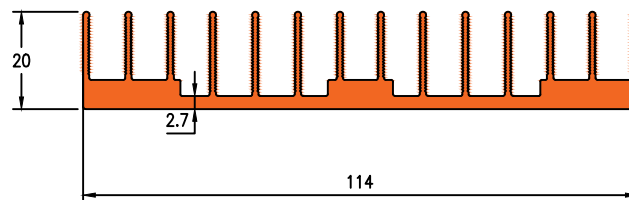

Die No.19003

2.068KG/M

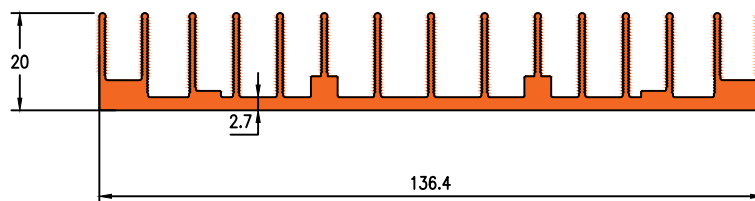

HEAT SINK



Darshan Extrusions Pvt. Ltd.

Die No. 7061

2.336KG/M

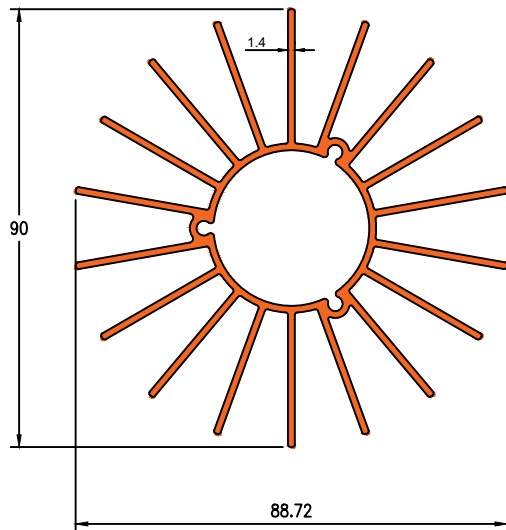

Die No. 19019

6.452KG/M

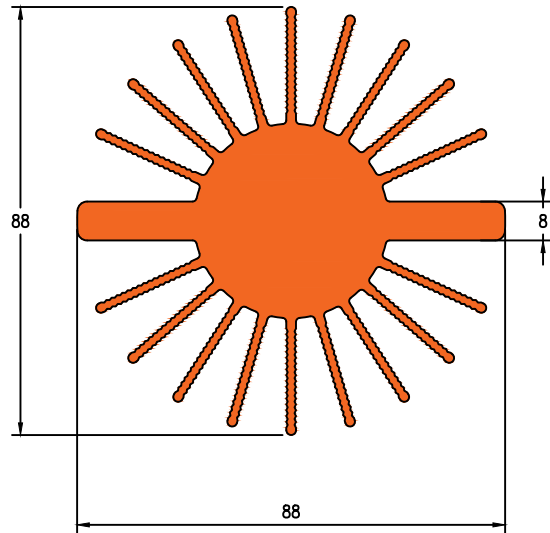

Die No. 19020

4.967KG/M

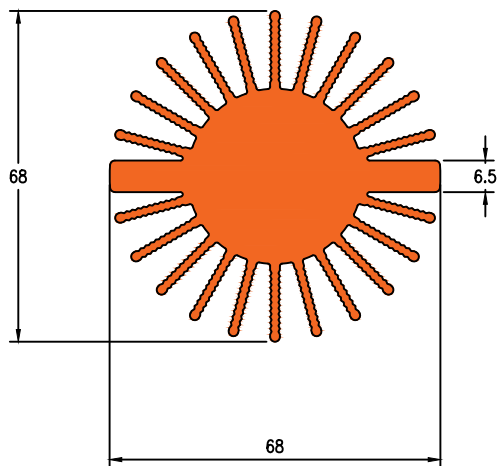

Die No. 19018

0.393KG/M

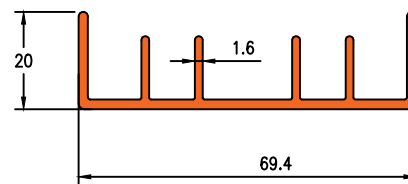

Die No. 19381

0.093KG/M

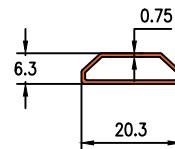

HEAT SINK



Darshan Extrusions Pvt. Ltd.

Die No.19137

1.423KG/M

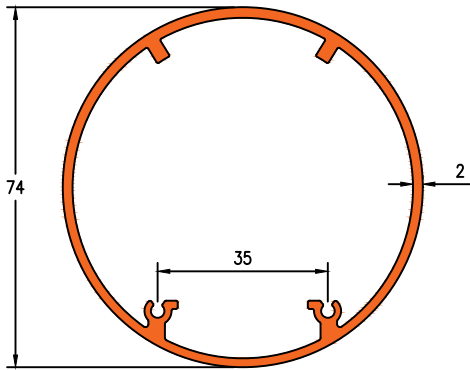

Die No.19138

2.030KG/M

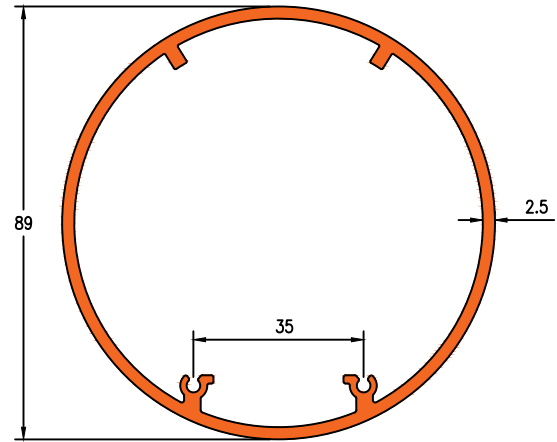

Die No.19139

4.140KG/M

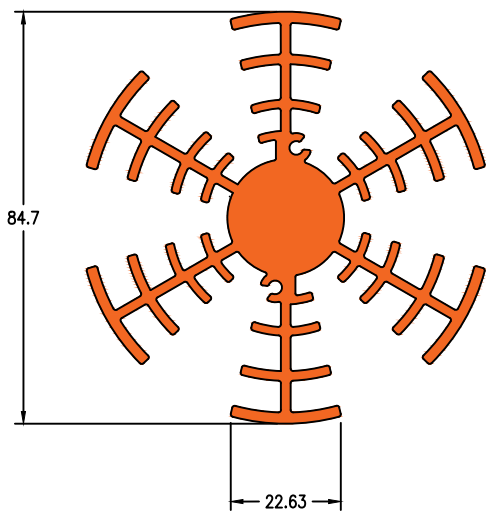

Die No.19140

3.481KG/M

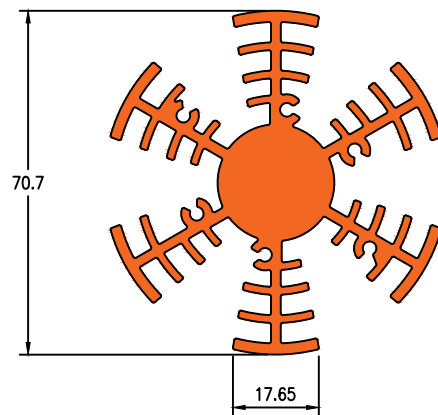

HEAT SINK



Darshan Extrusions Pvt. Ltd.

Die No.19067

1.736KG/M

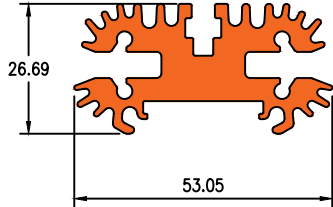

Die No.19524

4.418KG/M

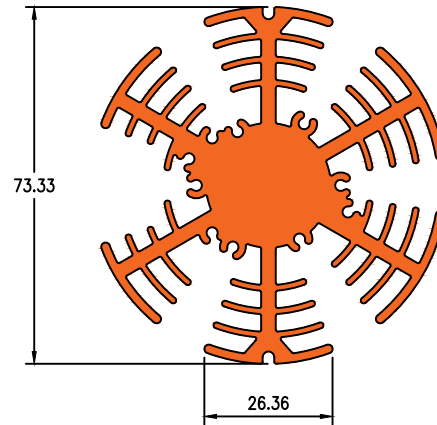

Die No.19525

3.217KG/M

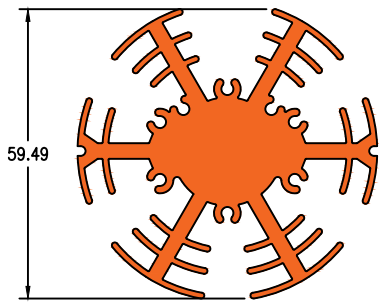

Die No.19526

2.176KG/M

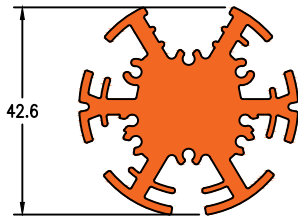

Die No.19818

2.750KG/M

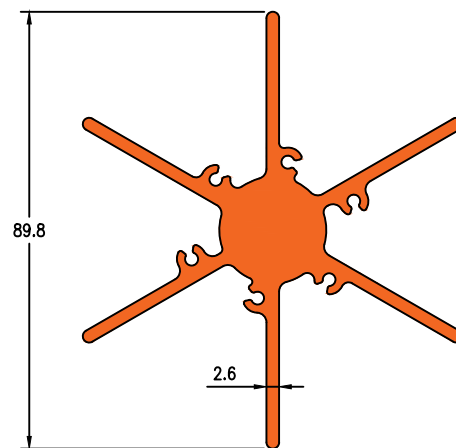

Die No.19385

3.244KG/M

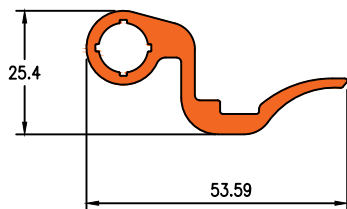

HEAT SINK



Darshan Extrusions Pvt. Ltd.

Die No.23009

3.175KG/M

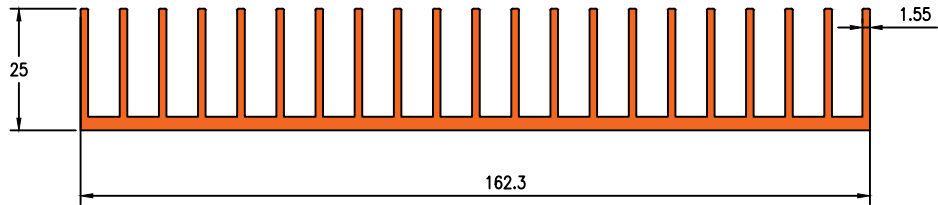

Die No.19958

9.823KG/M

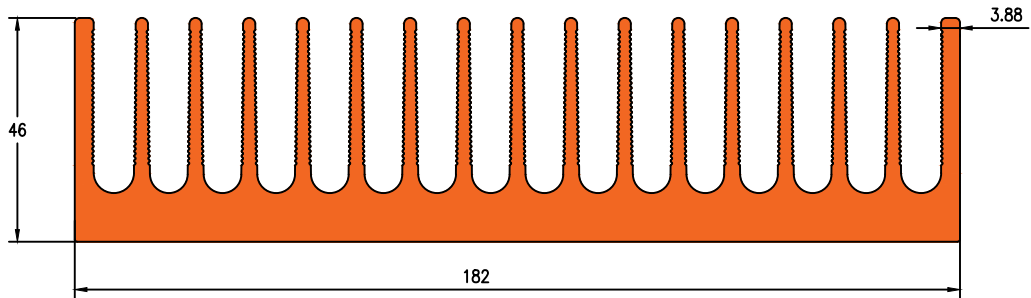

Die No.19819

2.291KG/M

Die No.19393

1.747KG/M

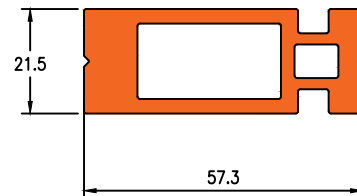
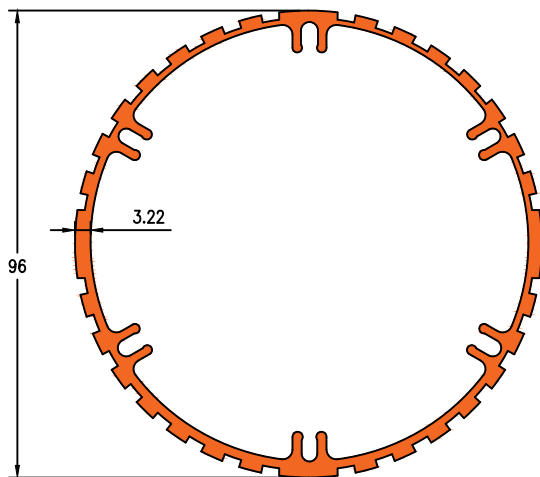

Die No.19382

0.151KG/M

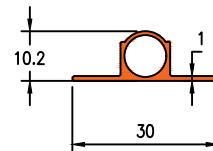

HEAT SINK



Darshan Extrusions Pvt. Ltd.

Die No.19535

0.623KG/M

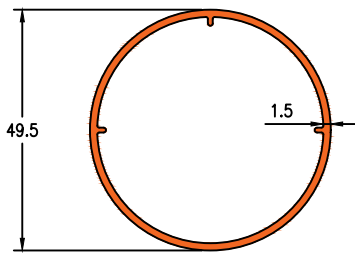

Die No.19532

1.161KG/M

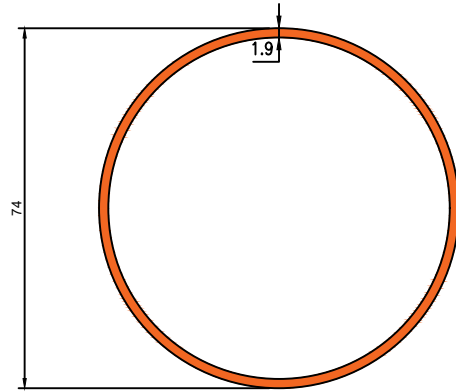

Die No.19392

2.551KG/M

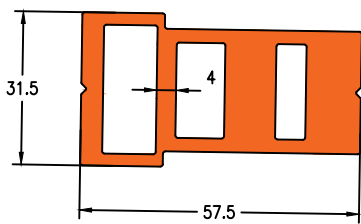

Die No.19533

1.098KG/M

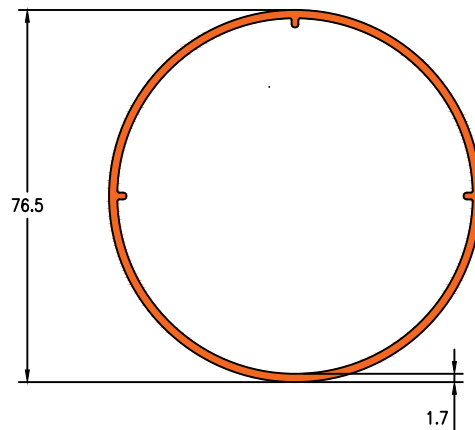

Die No.19534

0.667KG/M

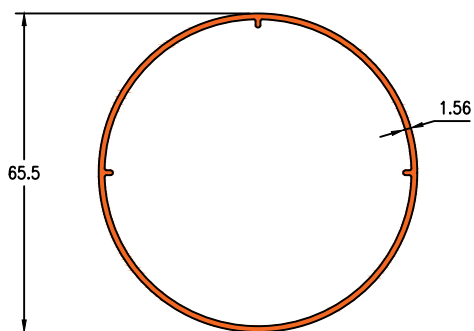

Die No.19014

0.502KG/M

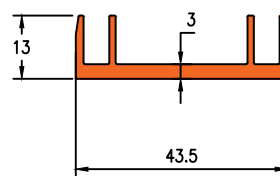

HEAT SINK



Darshan Extrusions Pvt. Ltd.

Die No. 19480

0.335KG/M

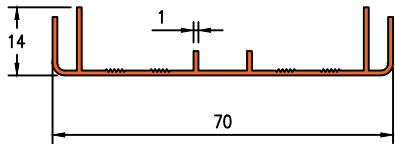

Die No. 20021

3.250KG/M

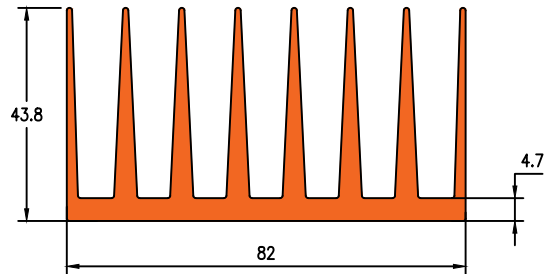

Die No. 23010

0.613KG/M

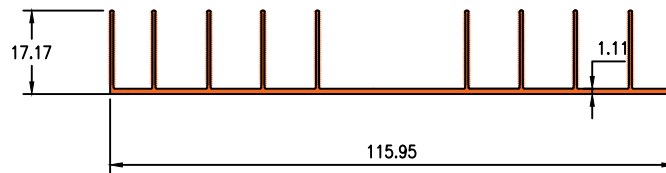

Die No. 19995

1.297KG/M

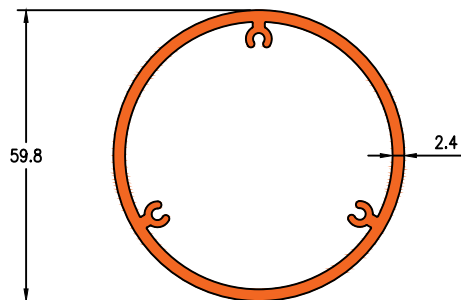

Die No. 19996

2.269KG/M

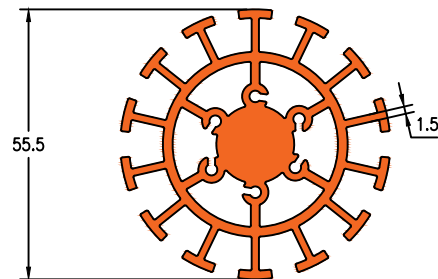

HEAT SINK



Darshan Extrusions Pvt. Ltd.

Die No.19401

0.183KG/M

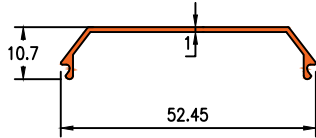

Die No.19400

0.280KG/M

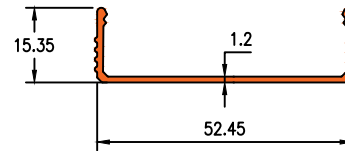

Die No.19635

0.135KG/M

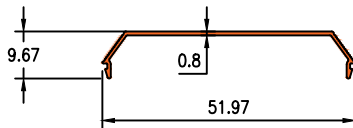

Die No.19634

0.174KG/M

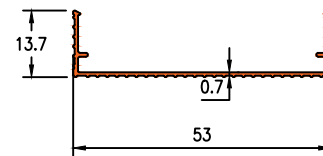

Die No.19523

0.121KG/M

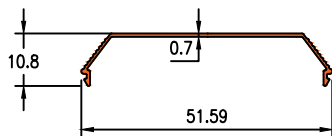

Die No.19521

0.184KG/M

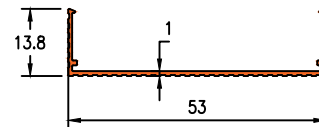

Die No.19522

0.117KG/M

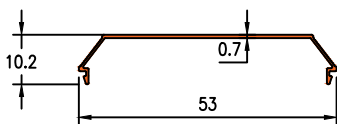

LED



Darshan Extrusions Pvt. Ltd.

Die No. 19686

0.110KG/M

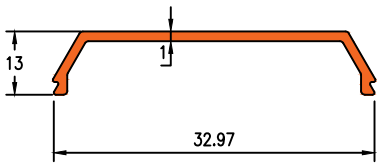

Die No. 19687

0.210KG/M

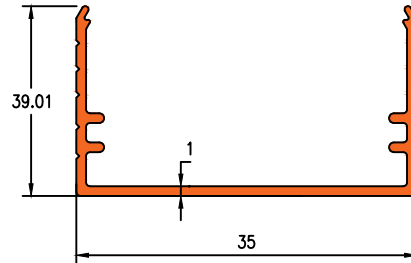

Die No. 19693

0.285KG/M

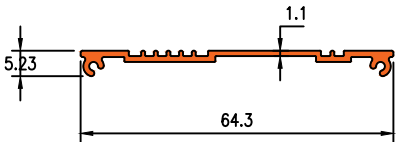

Die No. 19692

0.653KG/M

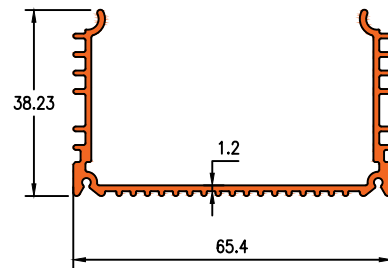

Die No. 19001

0.220KG/M

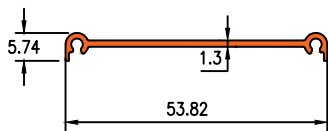

Die No. 19000

0.374KG/M

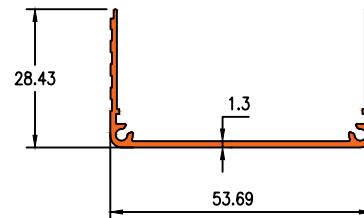

Die No. PB-4-3

0.418KG/M

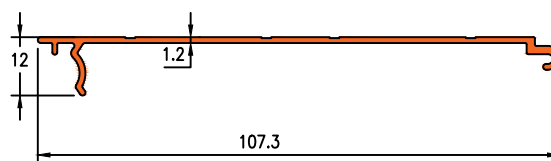

LED



Darshan Extrusions Pvt. Ltd.

Die No. PB-4-2

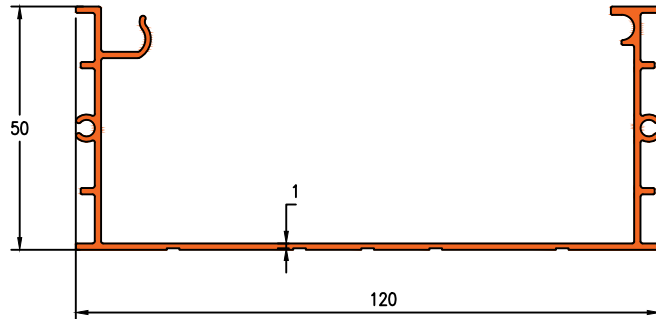

0.963KG/M

Die No. 19601

0.987KG/M

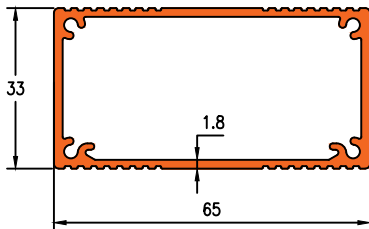

Die No.10204

1.067KG/M

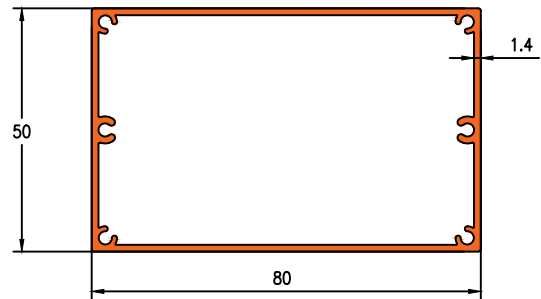

Die No. 19602

1.243KG/M

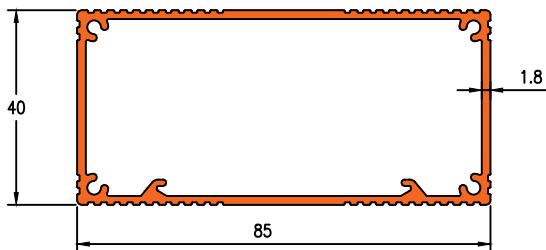

Die No.1302

1.057KG/M



Die No. 19110

1.572KG/M

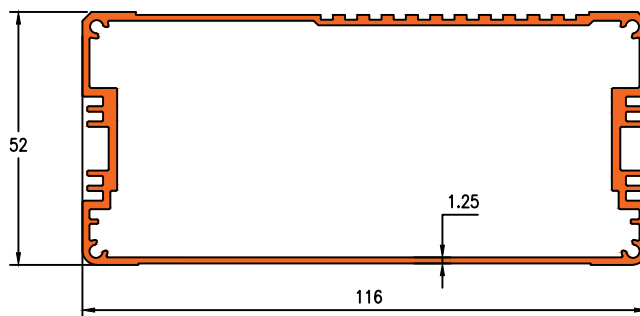

LED



Darshan Extrusions Pvt. Ltd.

Die No. 1266

1.023 KG/M

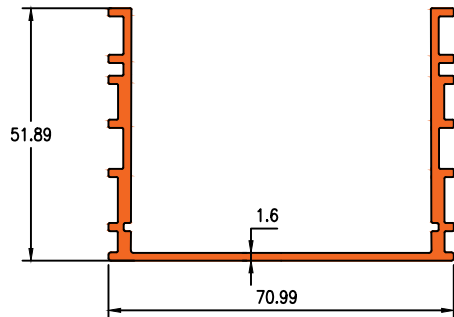

Die No. 16025

1.217 KG/M

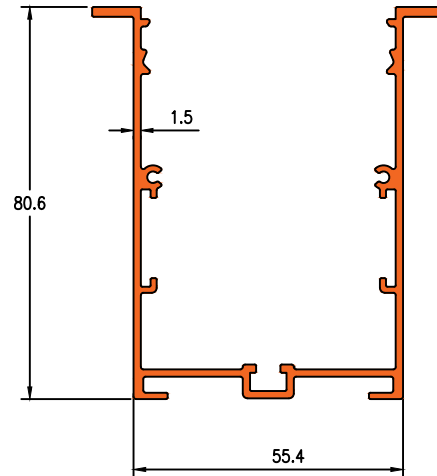

Die No. 16024

1.125 KG/M

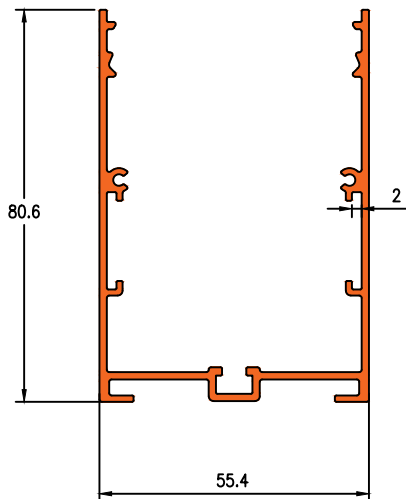

Die No. 19373

1.228 KG/M

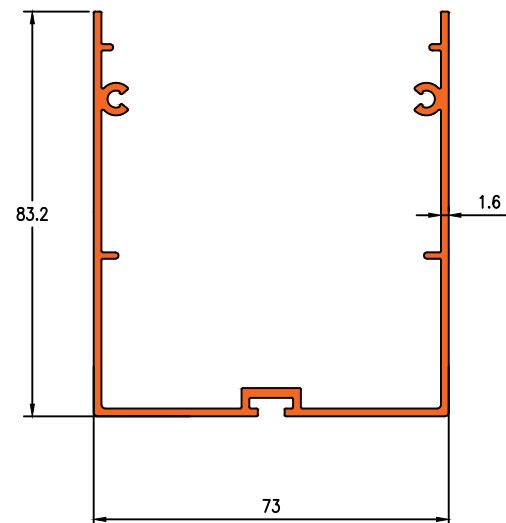

Die No. 19106

1.083 KG/M

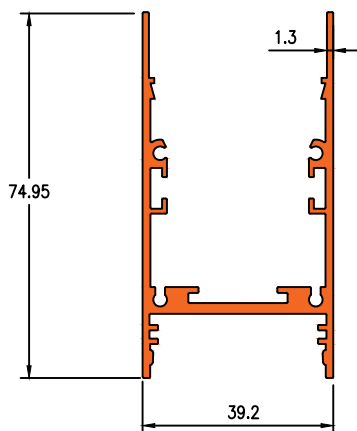

LED



Darshan Extrusions Pvt. Ltd.

Die No. 19732

1.648KG/M

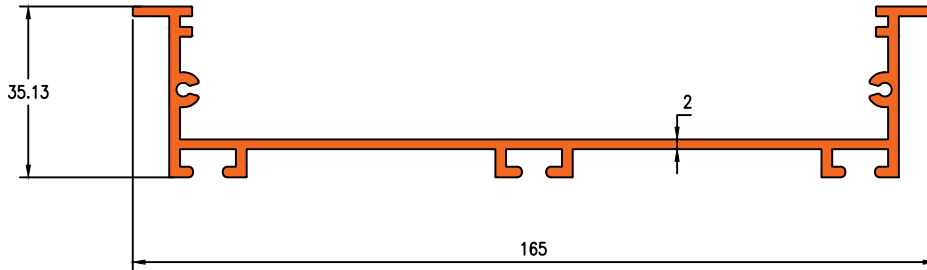

Die No. 19734

0.455KG/M

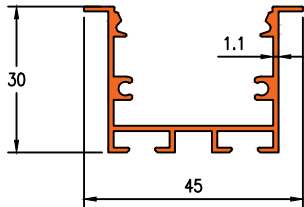

Die No. 19904

0.485KG/M

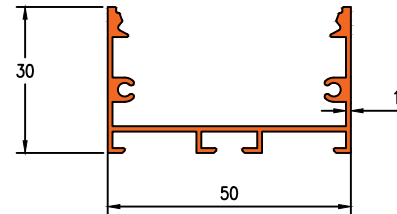

Die No. 19907

0.469KG/M

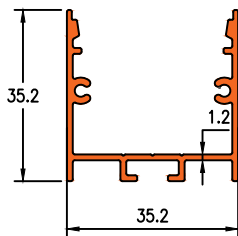

Die No. 1267

0.761KG/M

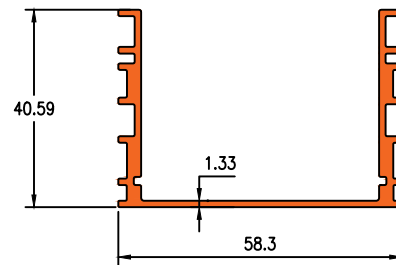

Die No. 19437

0.458KG/M

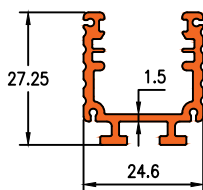

Die No. 19701

0.451KG/M

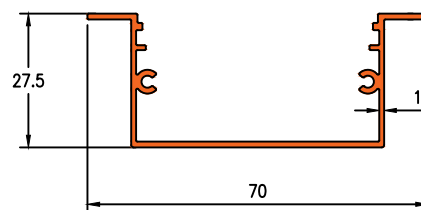

LED



Darshan Extrusions Pvt. Ltd.

Die No. 23005

0.264KG/M

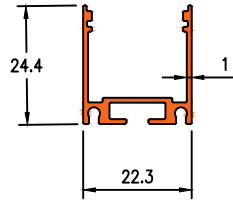

Die No. 23007

0.286KG/M

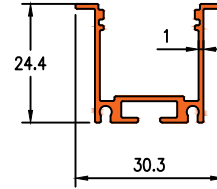

Die No. 23006

0.078KG/M

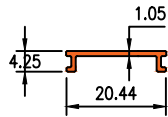

Die No. 19741

0.797KG/M

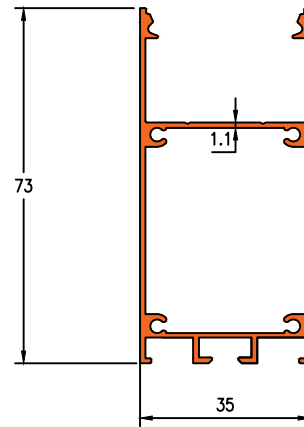

Die No. 19158

0.966KG/M

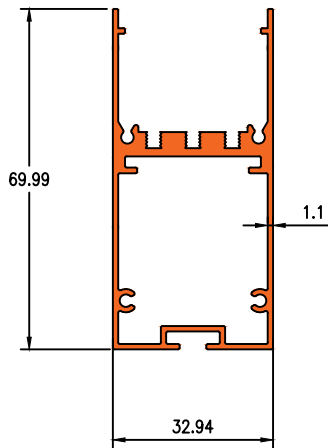

Die No. 16164

1.077KG/M

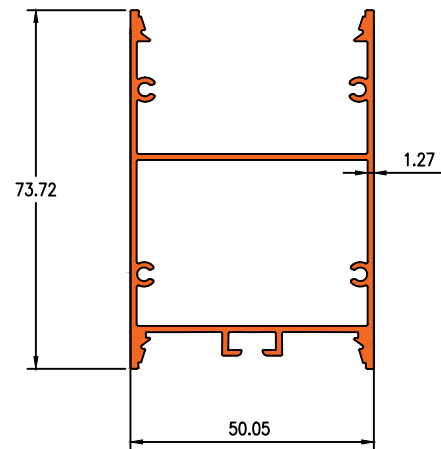

LED



Darshan Extrusions Pvt. Ltd.

Die No. 19908

1.106 KG/M

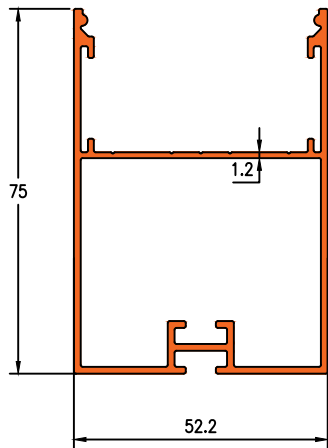

Die No. 19173

0.906KG/M

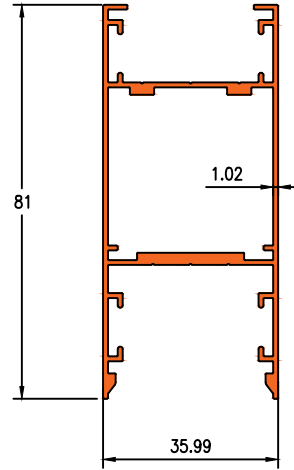

Die No. 19202

1.008KG/M

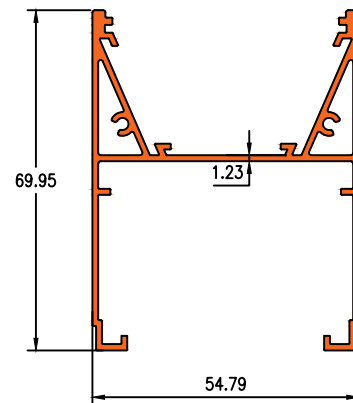

Die No. 19168

1.056KG/M

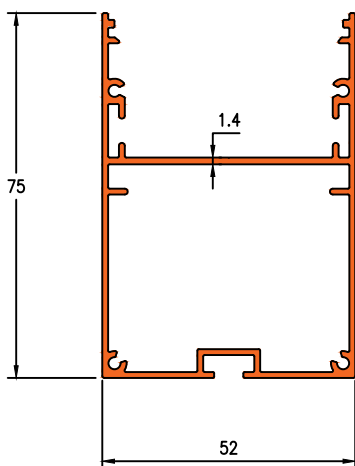

Die No. 19203

0.383KG/M

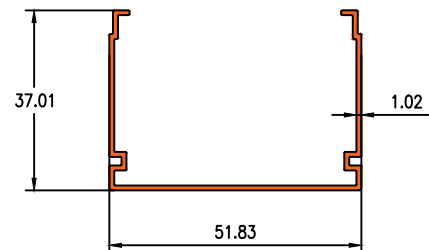

LED



Darshan Extrusions Pvt. Ltd.

Die No. 19190

0.897KG/M

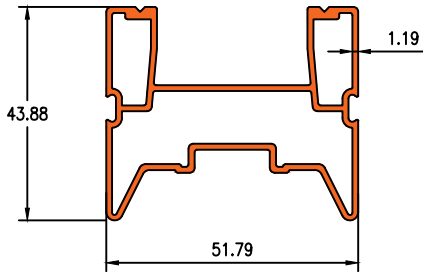

Die No. 19325

0.808KG/M

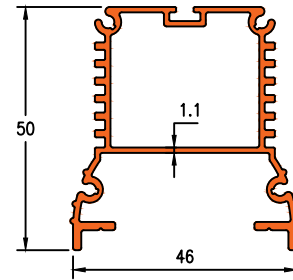

Die No. 1276

1.690KG/M

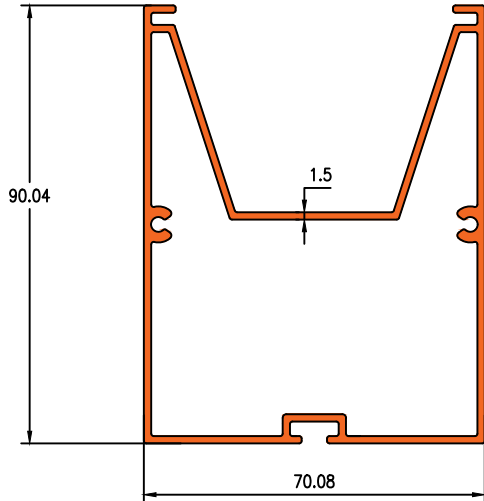

Die No. 19716

0.917KG/M

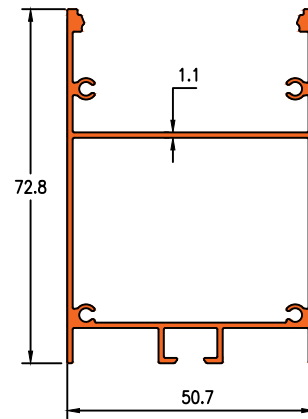

Die No. 19198

0.918KG/M

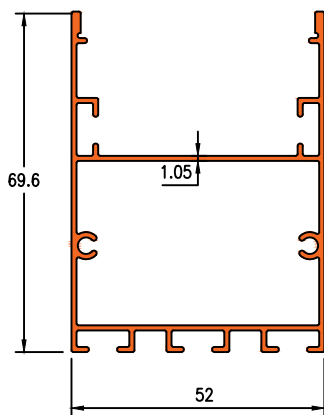

Die No. 19455

0.904KG/M

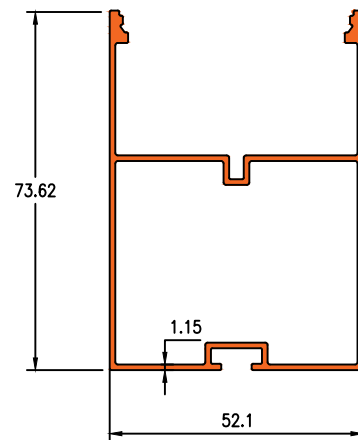

LED



Darshan Extrusions Pvt. Ltd.

Die No. 19193 0.985KG/M

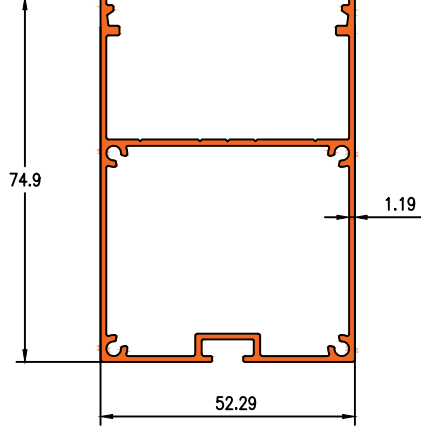

Die No. 19191 1.107KG/M

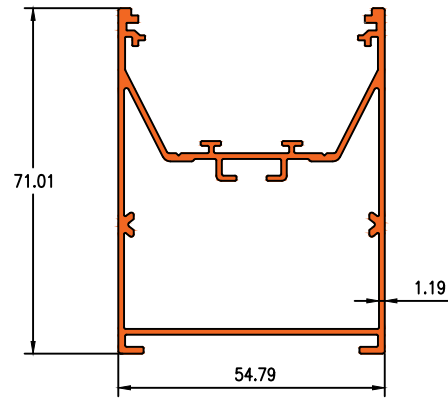

Die No. 1080 0.301KG/M

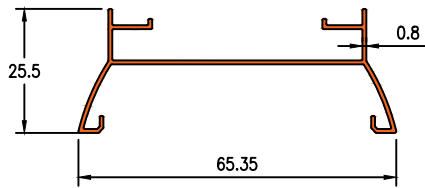

Die No. 1301 0.453KG/M

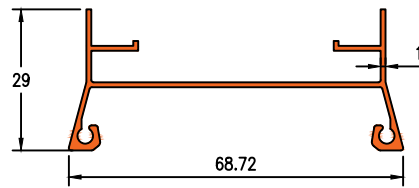

Die No. 19614 0.388KG/M

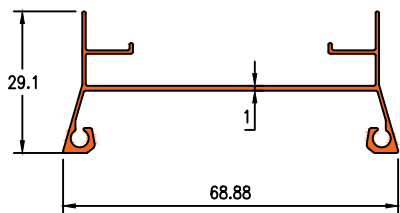

Die No. 19729 0.325KG/M

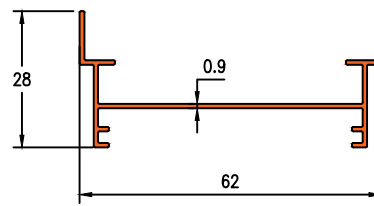

Die No. 19167 0.296KG/M

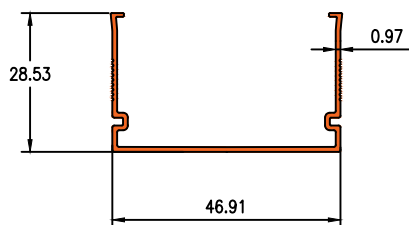

Die No. 19166 0.417KG/M

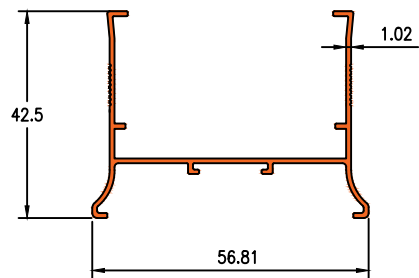

LED



Darshan Extrusions Pvt. Ltd.

Die No. 1275

0.145KG/M

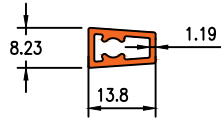

Die No. 19530

0.117KG/M

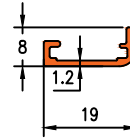

Die No. 19529

0.850KG/M

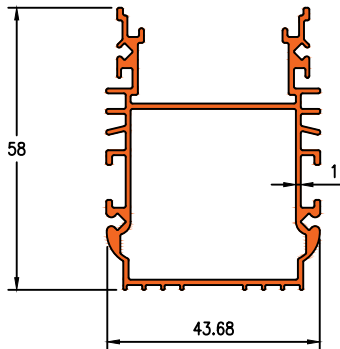

Die No. 19531

0.554KG/M

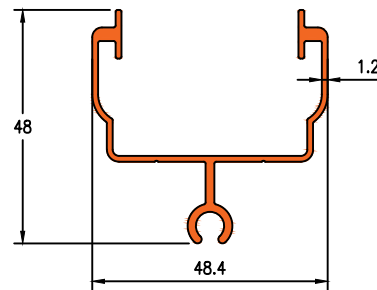

Die No. 19723

0.190KG/M

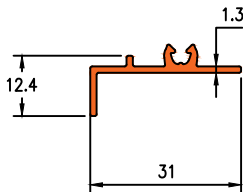

Die No. 19676

0.351KG/M

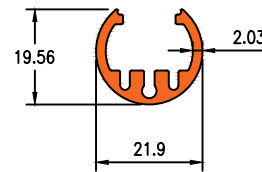

Die No. 1238

0.327KG/M

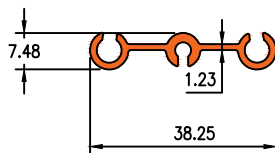

Die No. 1250

0.453KG/M

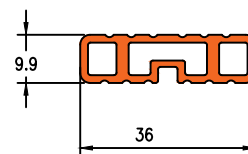

LED



Darshan Extrusions Pvt. Ltd.

Die No. 1248

0.522KG/M

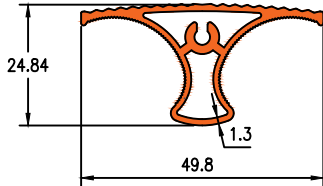

Die No. 19467

1.183KG/M

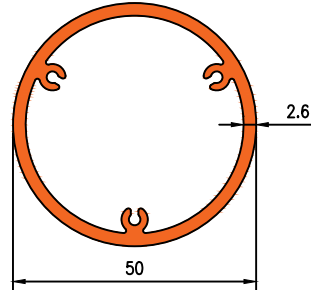

Die No. 19183

0.485KG/M

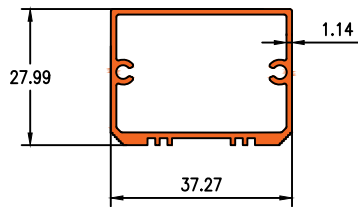

Die No. 1079

0.311KG/M

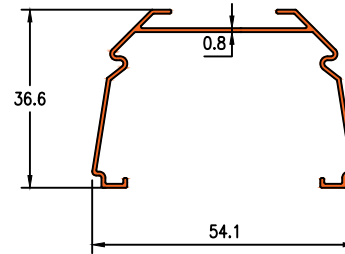

Die No. 1237

0.209KG/M

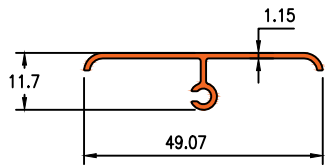

Die No. 1249

0.512KG/M

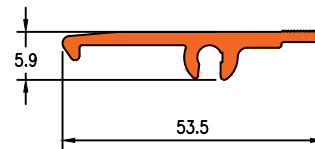

Die No. 1264

0.443KG/M

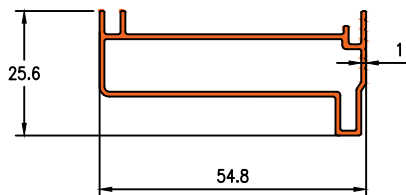

Die No. 1242

1.433KG/M

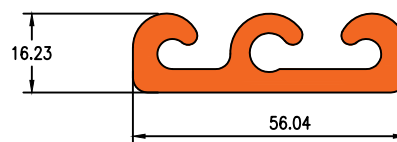

LED



Darshan Extrusions Pvt. Ltd.

Die No. 23018

0.435KG/M

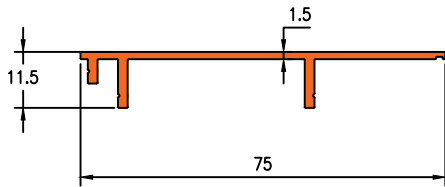

Die No. 19375

0.452KG/M

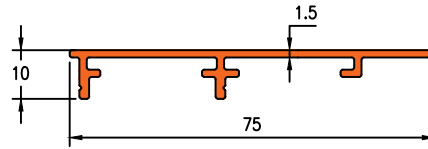

Die No. 1240

0.562KG/M

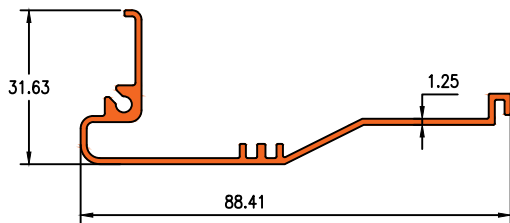

Die No. 19733

1.343KG/M

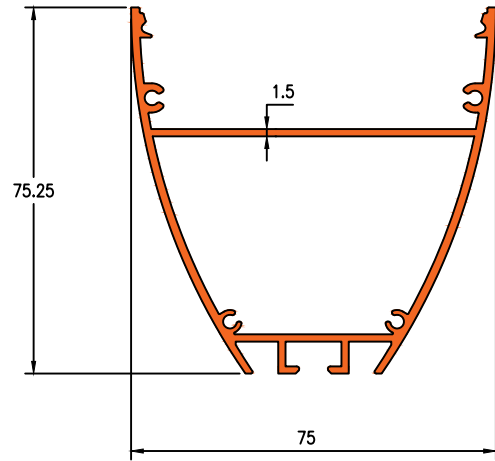

Die No. 20035

2.081KG/M

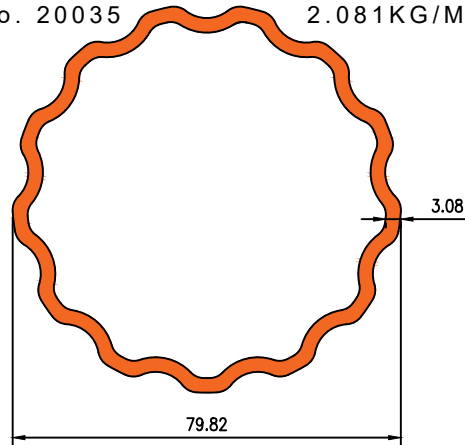

Die No. 20036

3.016KG/M

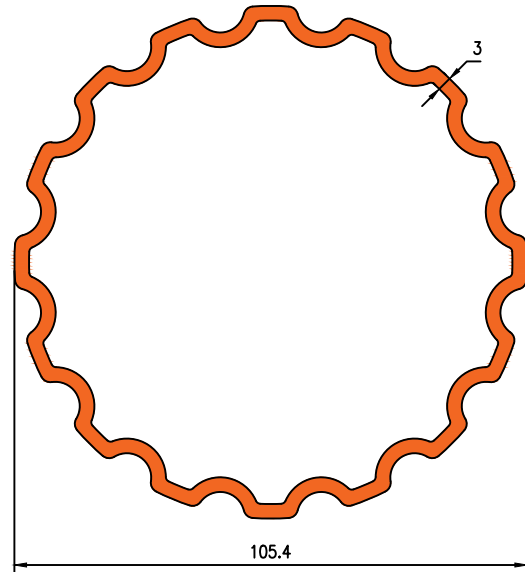

Die No. 1251

1.123KG/M

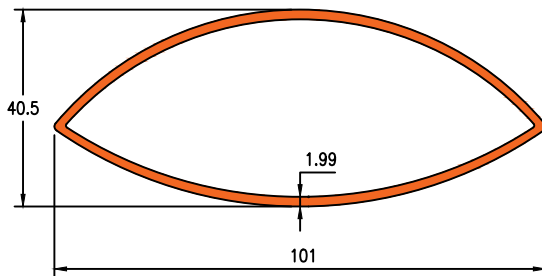

LED



Darshan Extrusions Pvt. Ltd.

Die No. 1278

1.313KG/M

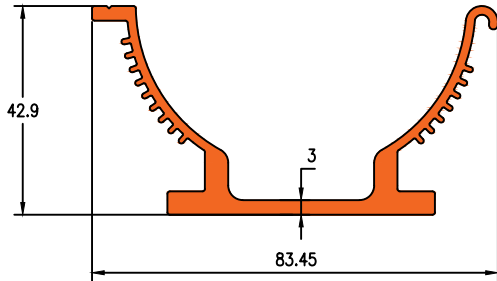

Die No. 1271

1.437KG/M

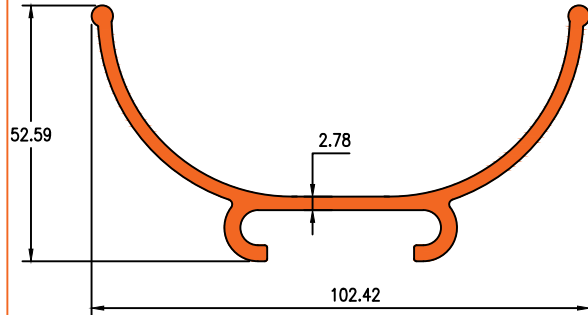

Die No. 1245

0.690KG/M

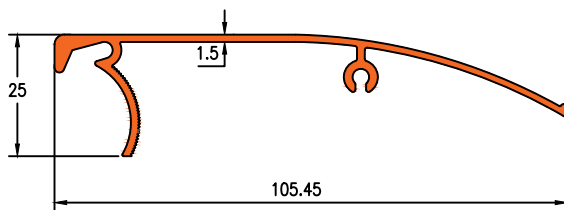

Die No. 1252

1.384KG/M

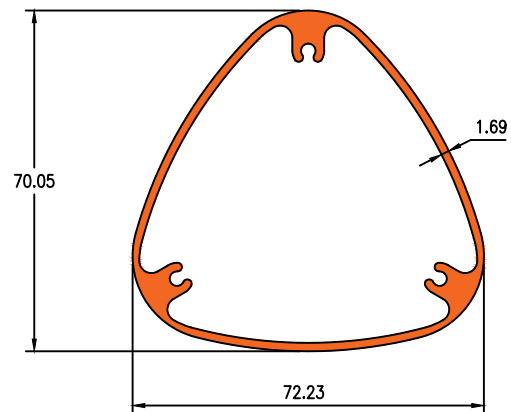

Die No. 19962

0.903KG/M

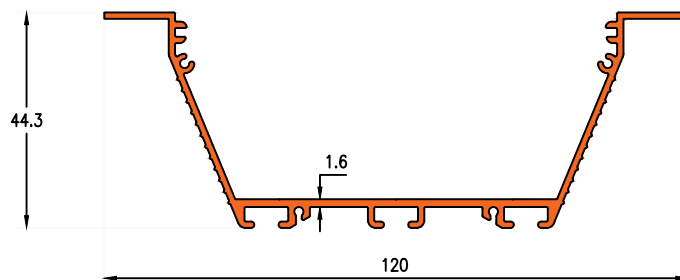

Die No. 1244

0.665KG/M

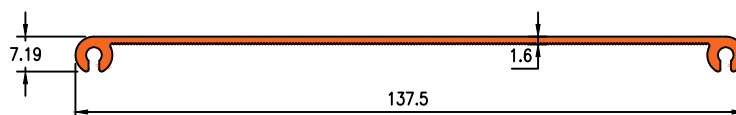

LED



Darshan Extrusions Pvt. Ltd.

Die No.19074

2.730Kg/m

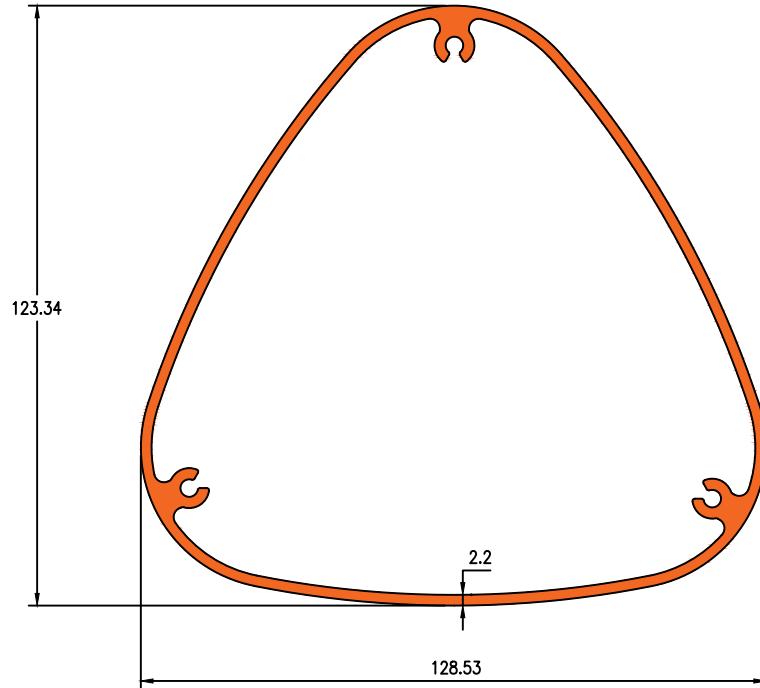

Die No.19075

2.120Kg/m

Die No.19076

2.370Kg/m

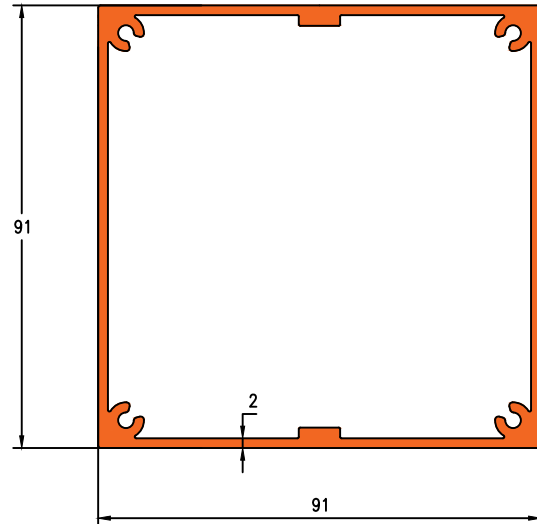
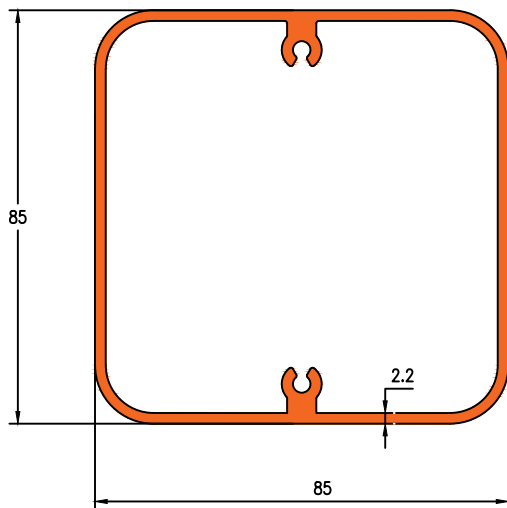

LED



Die No. 16241

0.750Kg/m

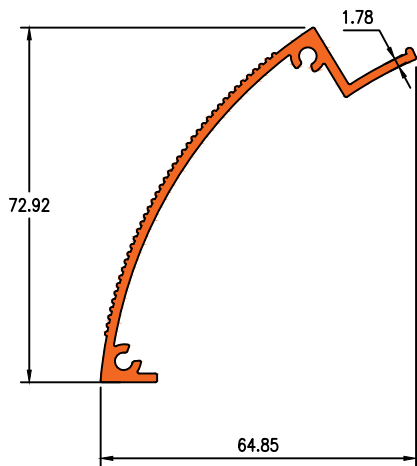

Die No. 1428

1.507Kg/m

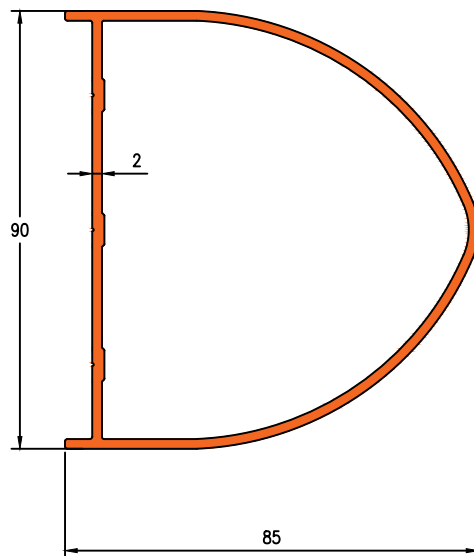

LED



Darshan Extrusions Pvt. Ltd.

Die No.19995

01.297 Kg/m

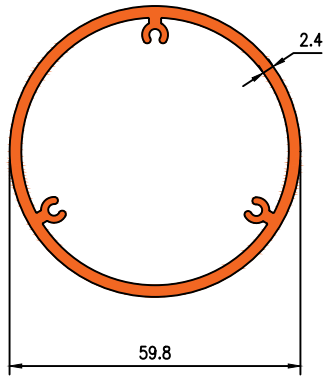

Die No.2008

1.910 Kg/m

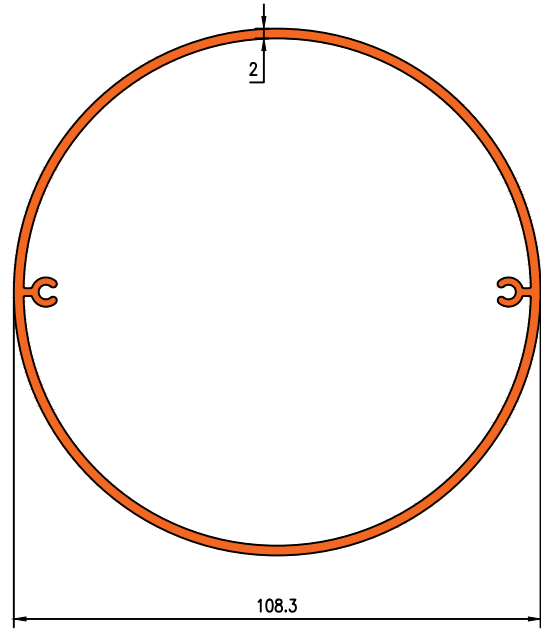

Die No.19995

1.910 Kg/m

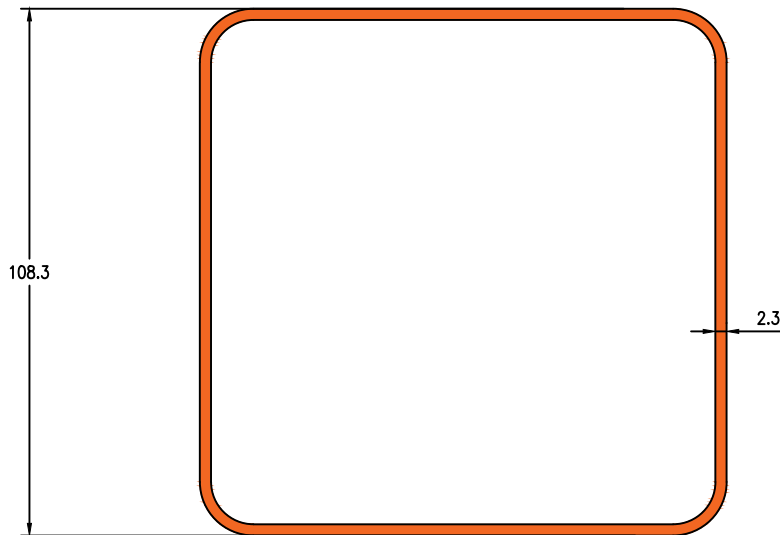

RAILWAY SECTION



Darshan Extrusions Pvt. Ltd.

Die No.19056

0.352KG/M

Die No.19169

0.429KG/M

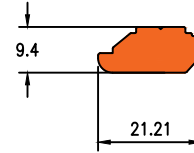
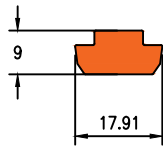

Die No.19057

0.392KG/M

Die No.19181

0.661KG/M

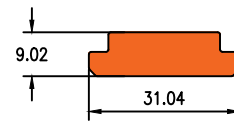
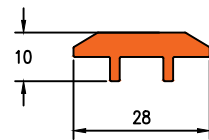

Die No.19131

0.389KG/M

Die No.19006

0.389KG/M

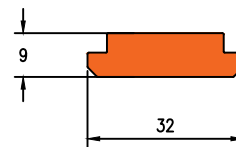
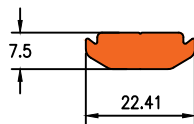

Die No.19159

0.203KG/M

Die No.19163

0.205KG/M

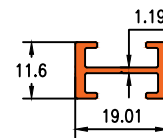
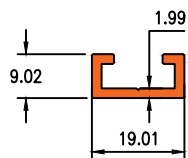

SOLAR



Darshan Extrusions Pvt. Ltd.

Die No.19069

0.809KG/M

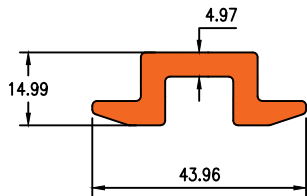

Die No.19432

0.750KG/M

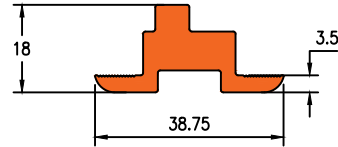

Die No.19811

0.277KG/M

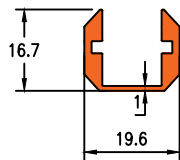

Die No.19831

0.247KG/M

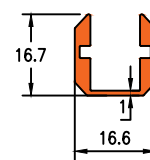

Die No. 19130

0.260KG/M

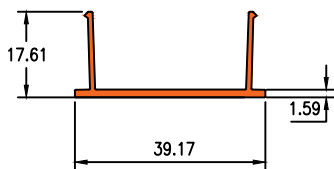

Die No.10203

0.358KG/M

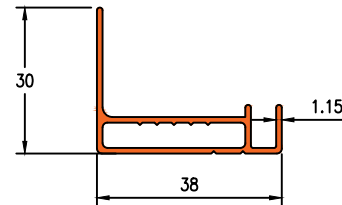

Die No.7001

0.786KG/M

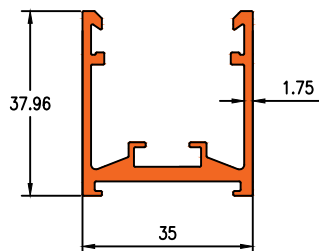

Die No.19051

0.695KG/M

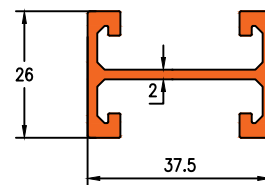

SOLAR



Darshan Extrusions Pvt. Ltd.

Die No. 7002

0.647KG/M

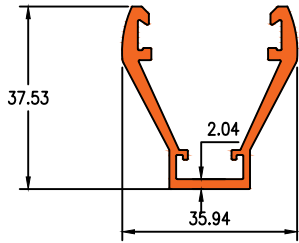

Die No. 7003

0.590KG/M

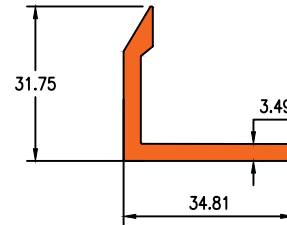

Die No. 19135

0.551KG/M

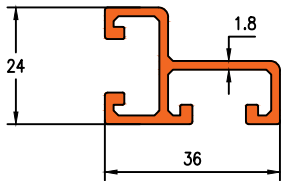

Die No. 19162

0.909KG/M

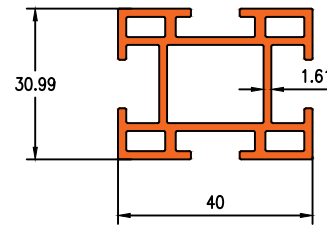

Die No. 7006

0.495KG/M

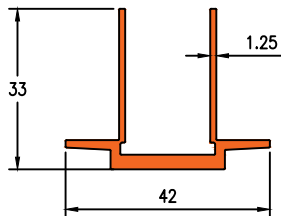

Die No. 7037

0.822KG/M

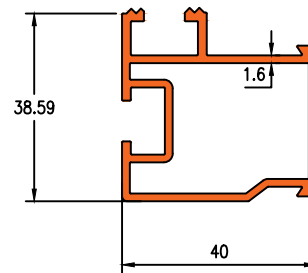

Die No. 7047

0.189KG/M

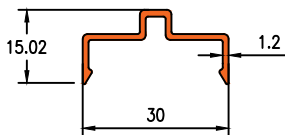

Die No. 7048

0.632KG/M

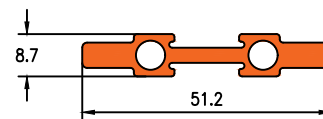

SOLAR



Darshan Extrusions Pvt. Ltd.

Die No. 7049

0.222KG/M

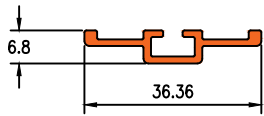

Die No. 19054

0.921KG/M

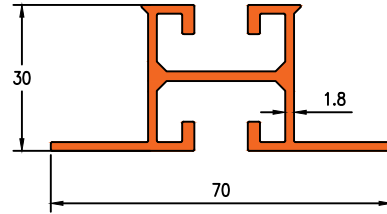

Die No. 7004

0.757KG/M

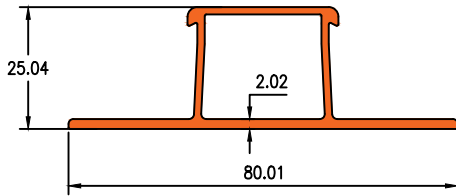

Die No. 19196

0.972KG/M

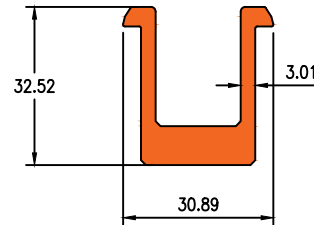

Die No. 19039

0.617KG/M

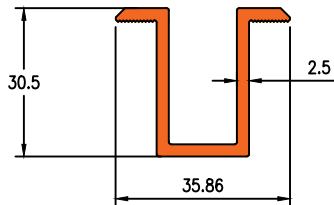

Die No. 19005

0.681KG/M

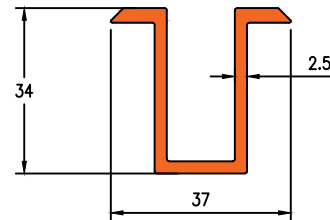

Die No. 19374

2.876KG/M

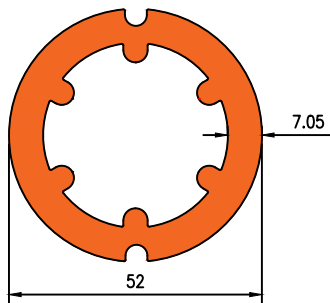

Die No. 19133

0.749KG/M

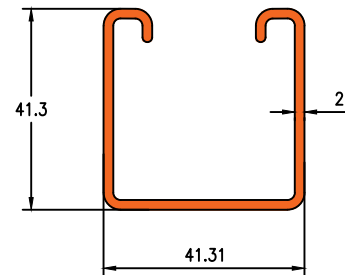

SOLAR



Darshan Extrusions Pvt. Ltd.

Die No.19040

0.534KG/M

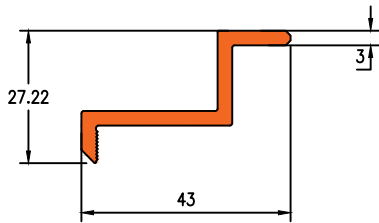

Die No.19043

0.565KG/M

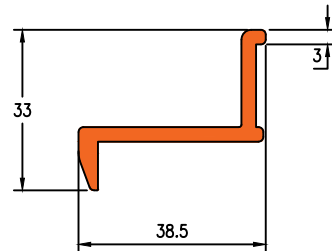

Die No.19044

0.606KG/M

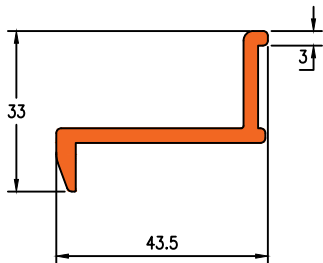

Die No.19055

0.529KG/M

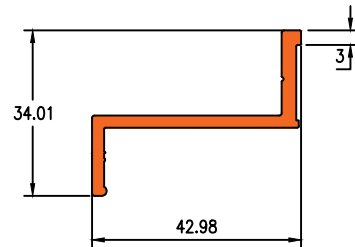

Die No.20055

0.656KG/M

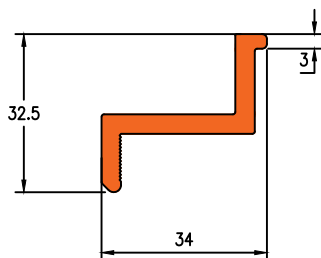

Die No.19070

0.403KG/M

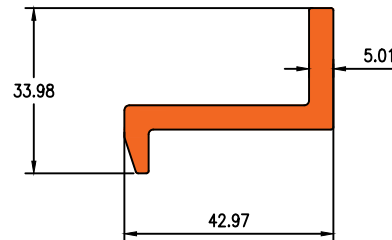

Die No.19004

0.576KG/M

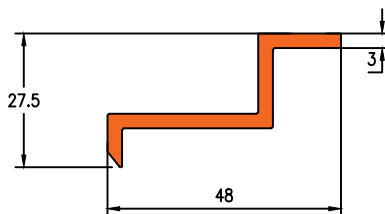

Die No.20055

0.656KG/M

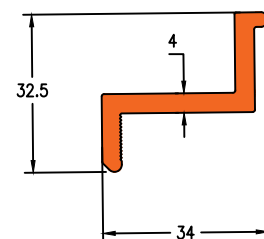

SOLAR



Darshan Extrusions Pvt. Ltd.

Die No.7028

1.176KG/M

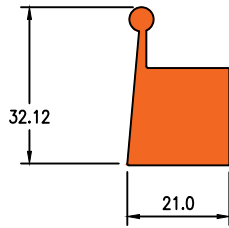

Die No.7026

0.269KG/M

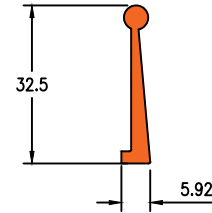

Die No.7027

2.489KG/M

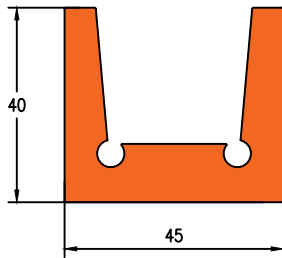

Die No.19042

3.465KG/M

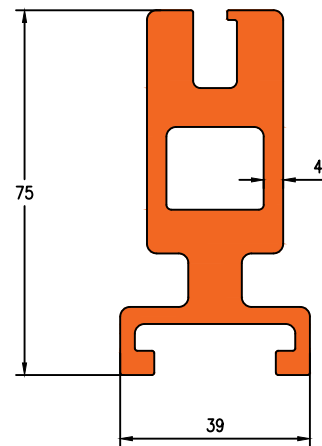

SOLAR



Darshan Extrusions Pvt. Ltd.

Die No.19041

4.561KG/M

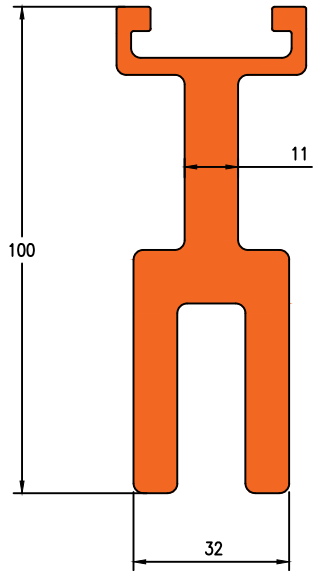

Die No.19488

3.022KG/M

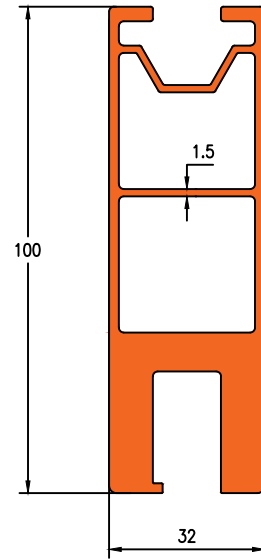

Die No.19097

1.458KG/M

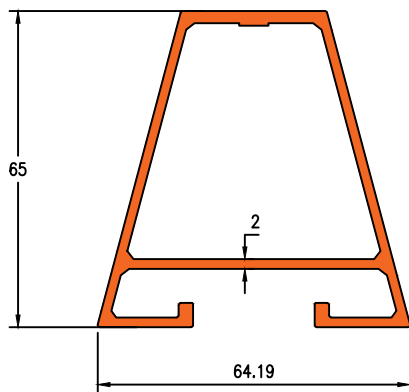

Die No.16104

1.593KG/M

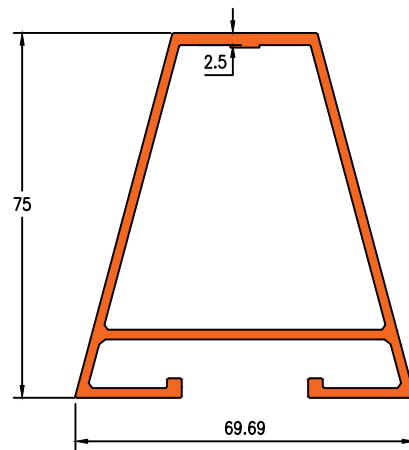

SOLAR



Darshan Extrusions Pvt. Ltd.

Die No.19007

1.218KG/M

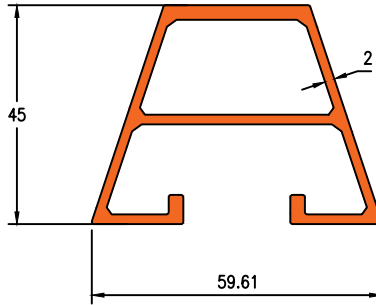

Die No.19087

1.030KG/M

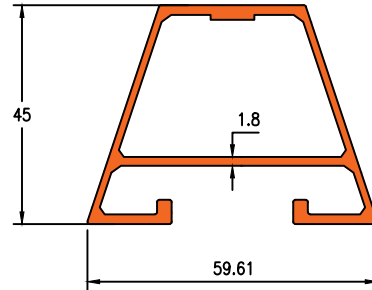

Die No.16217

1.298KG/M

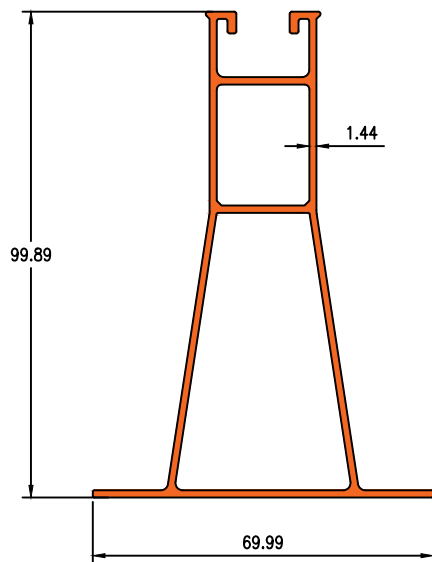

Die No.19433

1.669KG/M

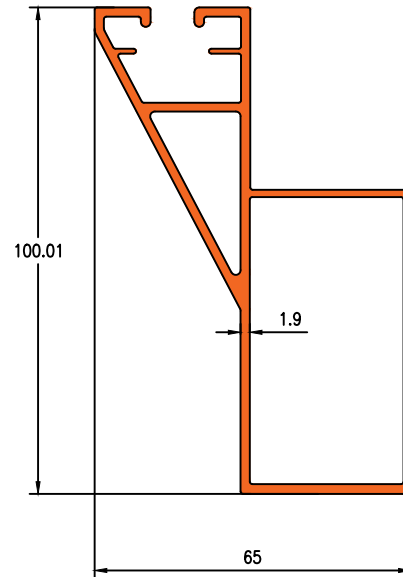

Die No.19999

1.254KG/M

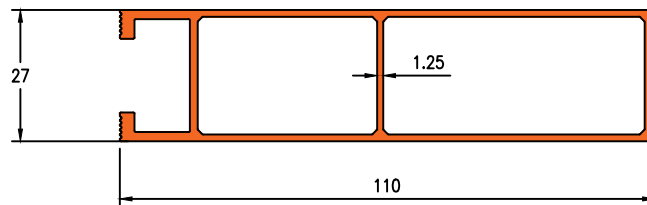

SOLAR



Darshan Extrusions Pvt. Ltd.

Die No.19165

1.217KG/M

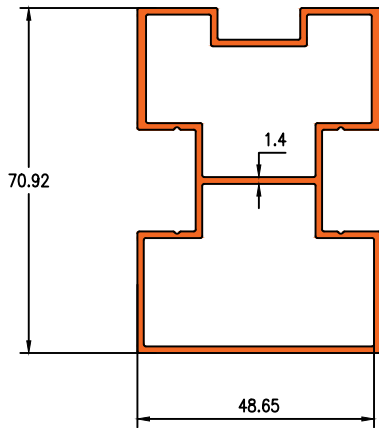

Die No.19160

1.286KG/M

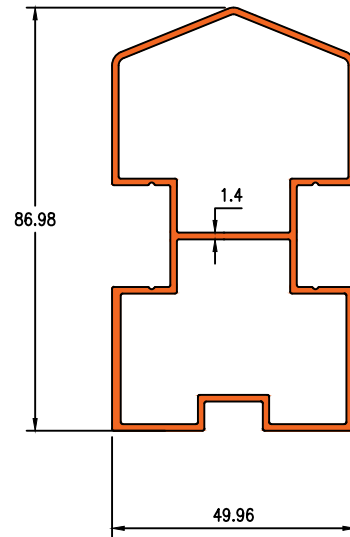

Die No.19079

1.056KG/M

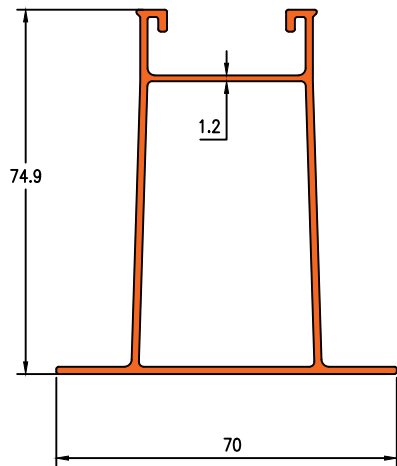

Die No.21020

1.309KG/M

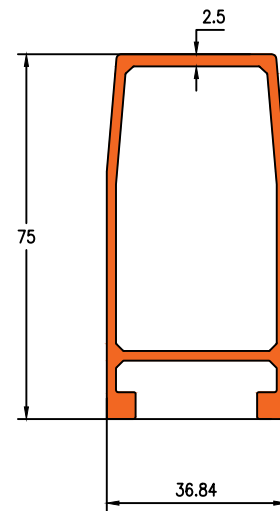

SOLAR



Darshan Extrusions Pvt. Ltd.

Die No.19999

1.254KG/M

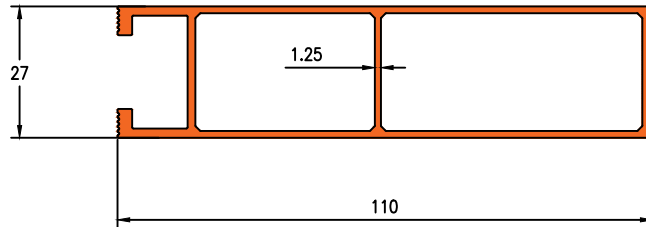

Die No.21020

1.309KG/M

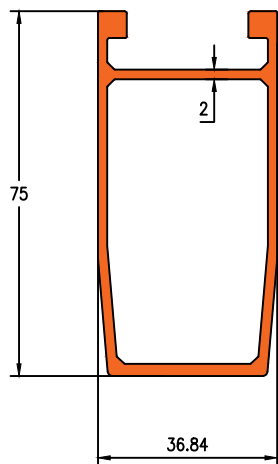

Die No.22101

2.302KG/M

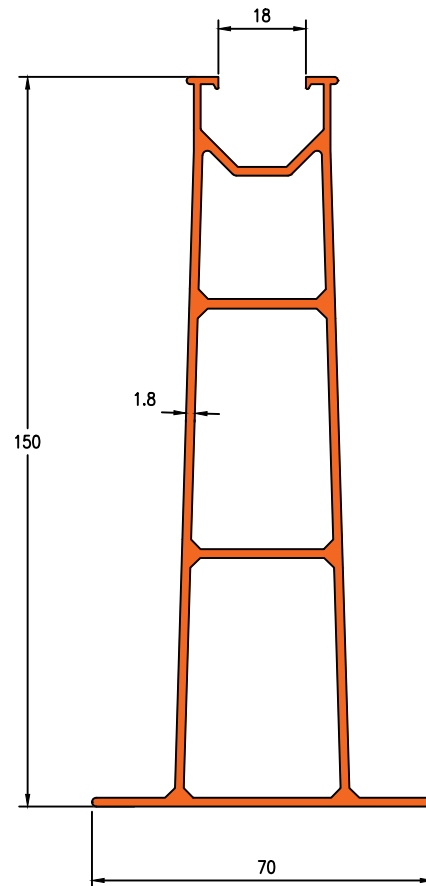

SOLAR



Darshan Extrusions Pvt. Ltd.

Die No.1243

0.620Kg/m

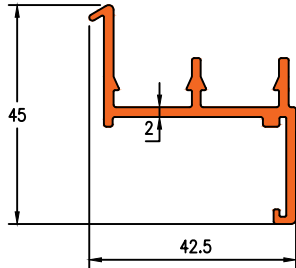

Die No.1222

0.579Kg/m

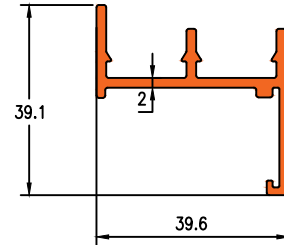

Die No.19142

4.932Kg/m

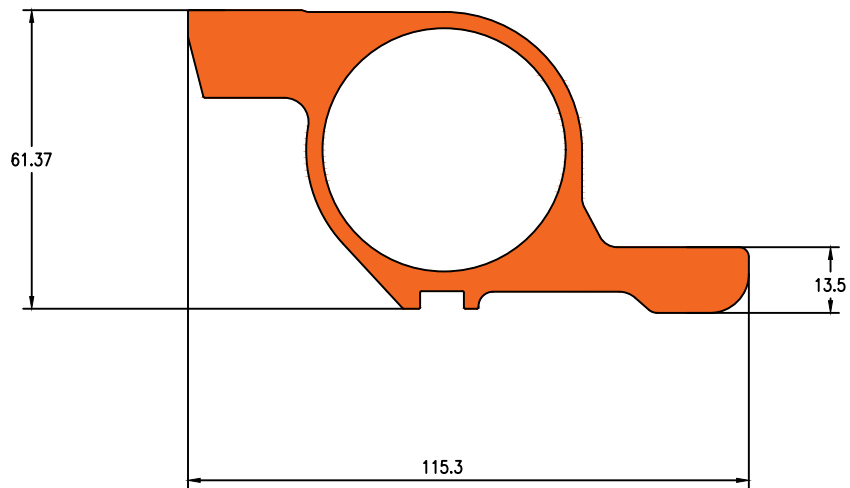

AUTOMOBILE



Darshan Extrusions Pvt. Ltd.

Die No.19501

5.237Kg/m

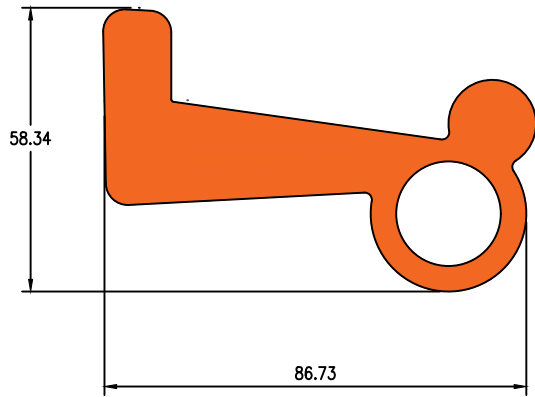

Die No.19502

3.219Kg/m

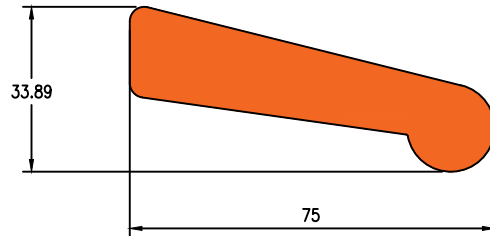

Die No.19547

4.558Kg/m

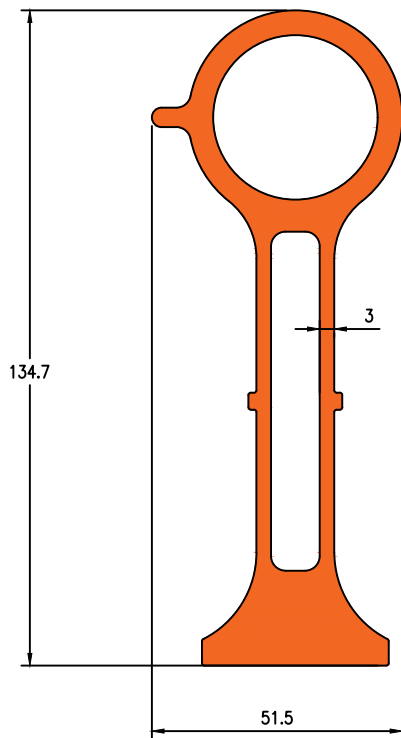

Die No.19546

7.431Kg/m

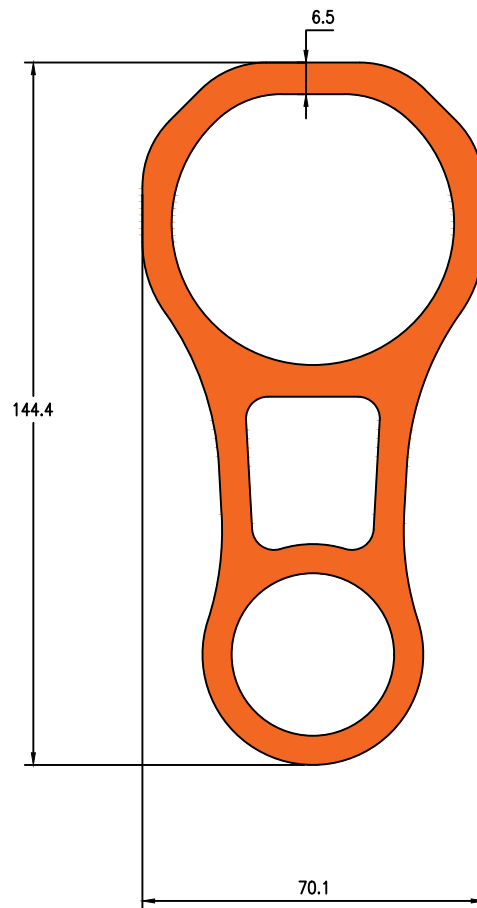

AUTOMOBILE



Darshan Extrusions Pvt. Ltd.

Die No.19548

4.190Kg/m

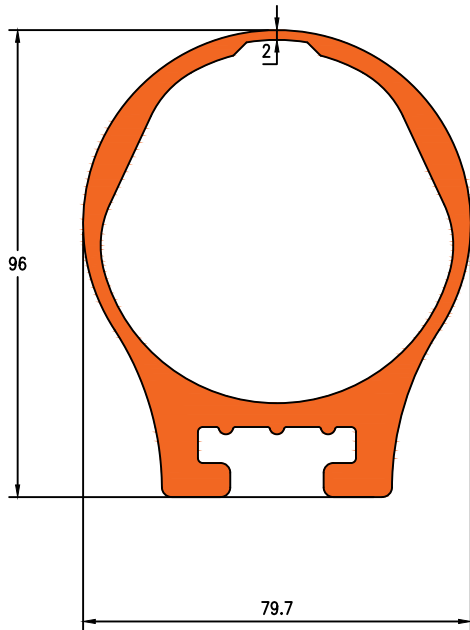

Die No.20744

5.707 Kg/m

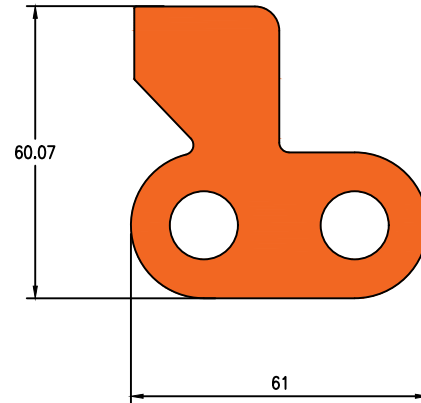

Die No.19143

8.140 Kg/m

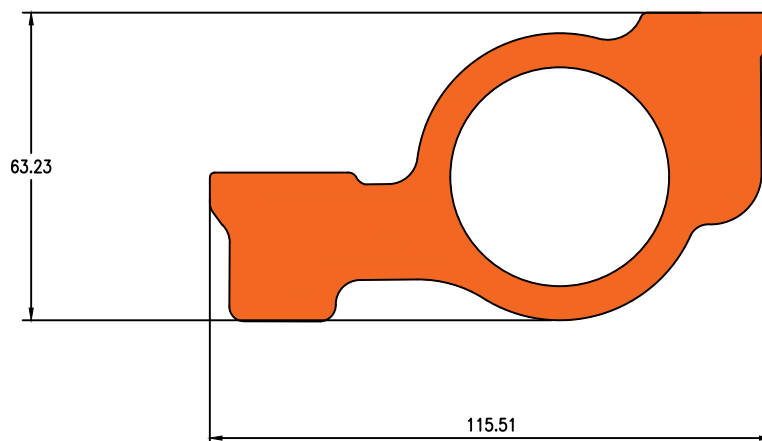

AUTOMOBILE



Die No.19144

8 . 260 Kg/m

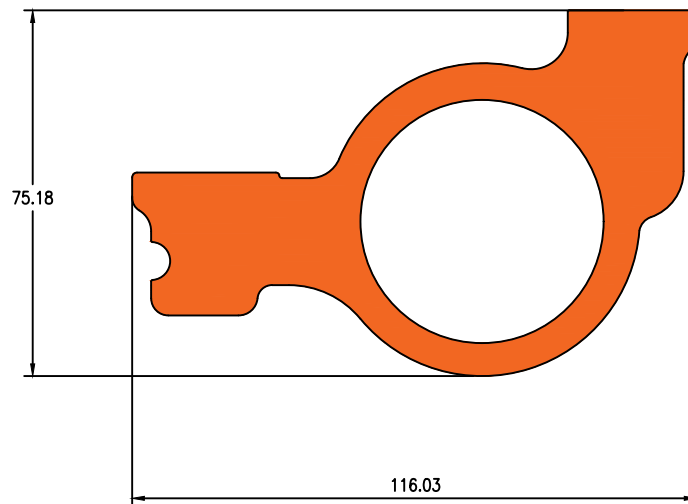

Die No.20741

7 . 538 Kg/m

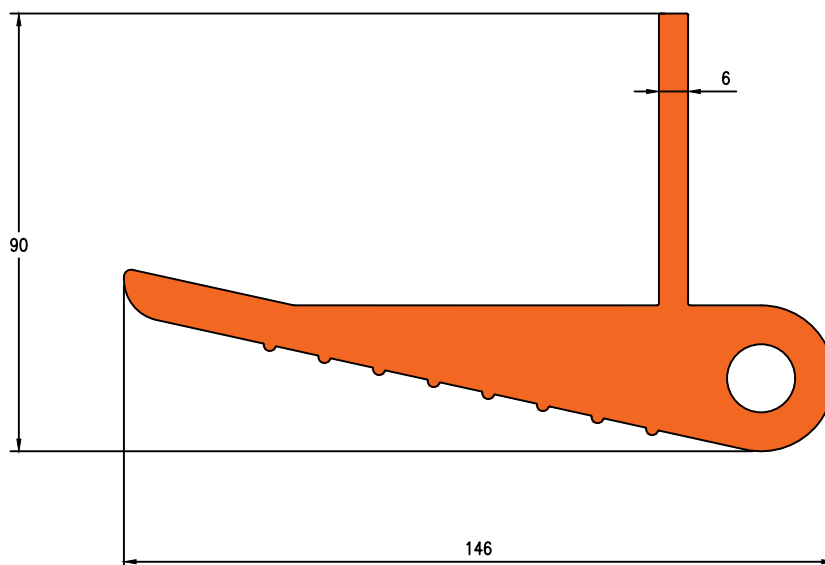



Die No.20743

3 . 70 Kg/m

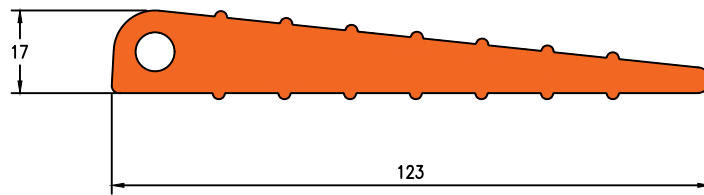

Die No.20740

6 . 024 Kg/m

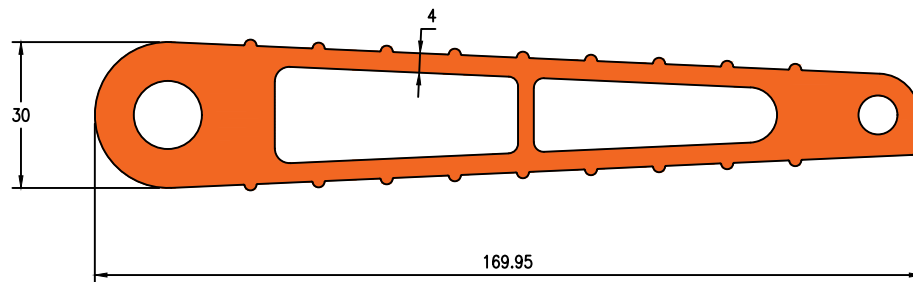

Die No.20742

4 . 253 Kg/m

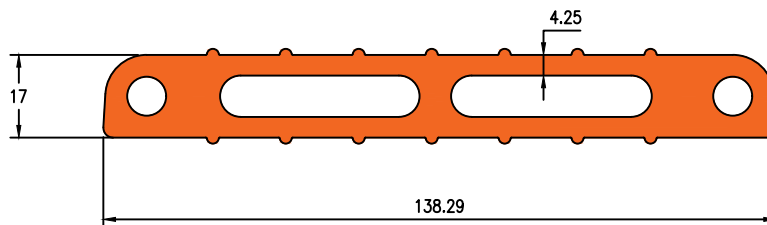



Darshan Extrusions Pvt. Ltd.

Die No. 1346

0.997Kg/m

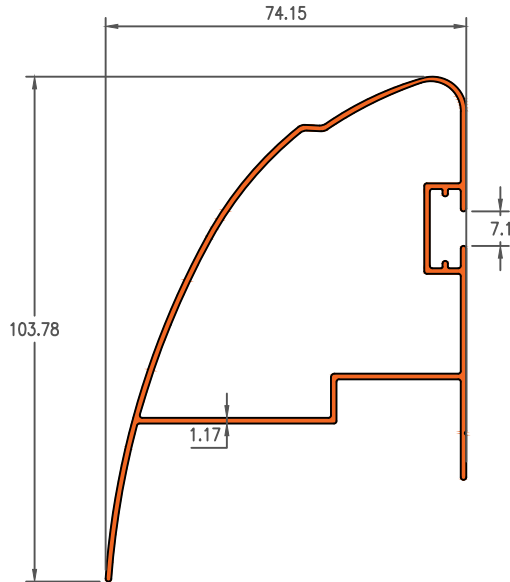

Die No. 1344

0.256Kg/m

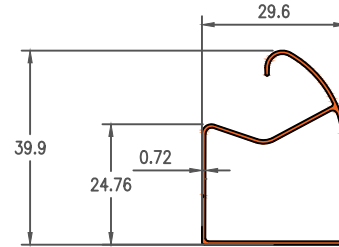

Die No. 9159

1.379Kg/m

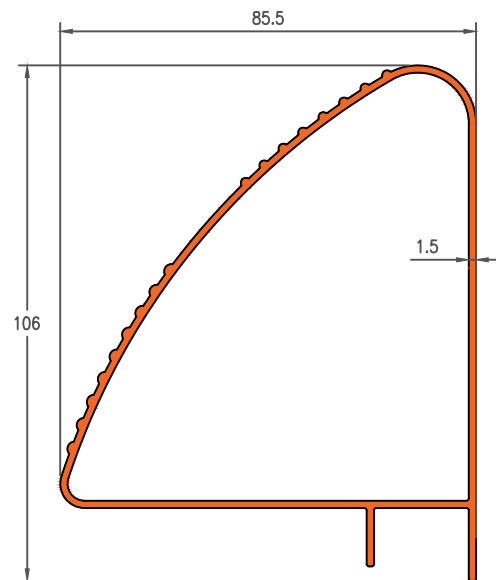

CARRIER



Darshan Extrusions Pvt. Ltd.

Die No.19418

0.520 Kg/m

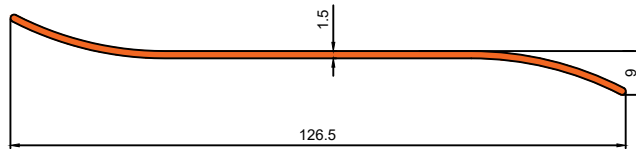

Die No.19503

1.771 Kg/m

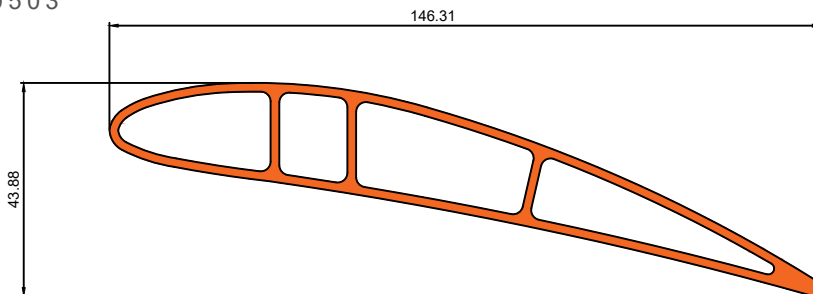

Die No.19536

1.957 Kg/m

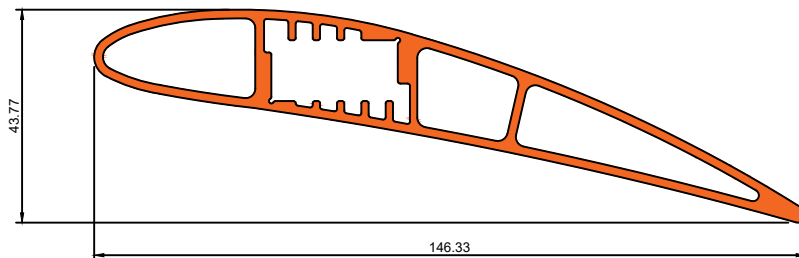

Die No.19971

2.282 Kg/m

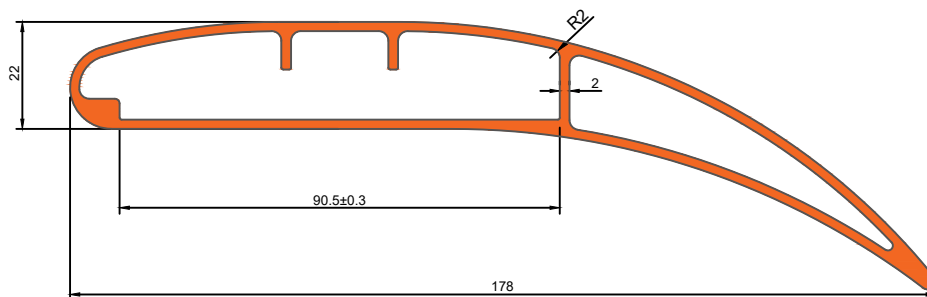

FAN BLADES



Darshan Extrusions Pvt. Ltd.

Die No. 19496

0.947 Kg/m

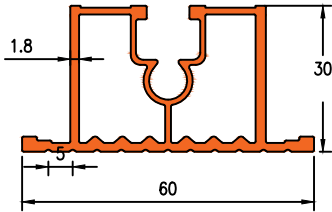

Die No. 20020

0.982 Kg/m

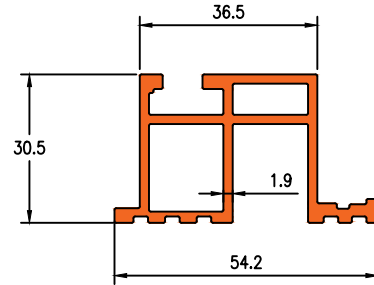

Die No.27025

1.221 Kg/m

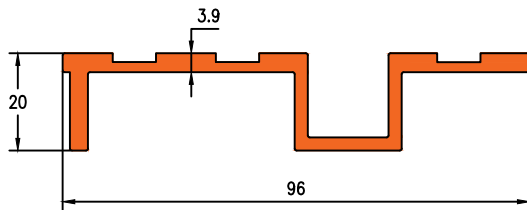

Die No.19429

0.880 Kg/m

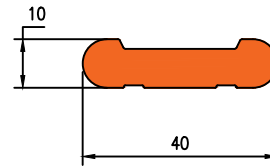

Die No.19696

1.078 Kg/m

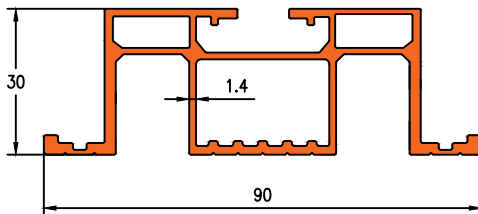

Die No.27024

0.782 Kg/m

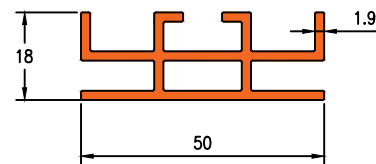

LIFT



Darshan Extrusions Pvt. Ltd.

Die No. 21120

0.368 Kg/m

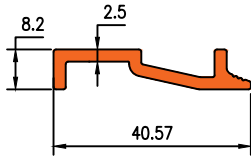

Die No. 21121

0.414 Kg/m

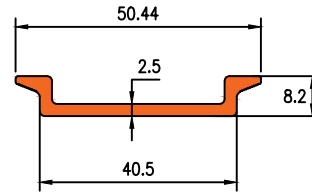

Die No. 21122

0.253 Kg/m

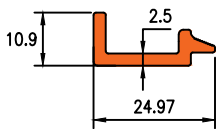

Die No. 21123

0.776 Kg/m

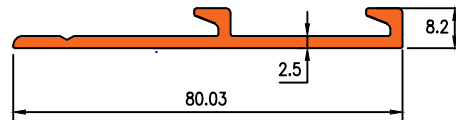

Die No. 21124

0.666 Kg/m

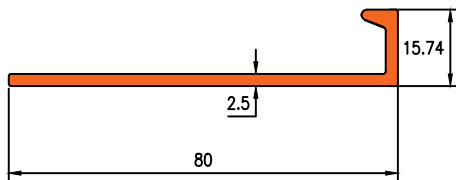

Die No. 21125

0.669 Kg/m

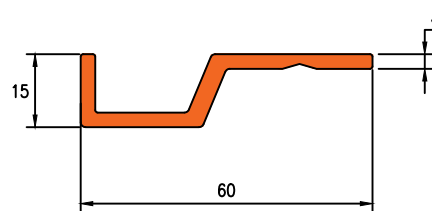

Die No. 21126

0.771 Kg/m

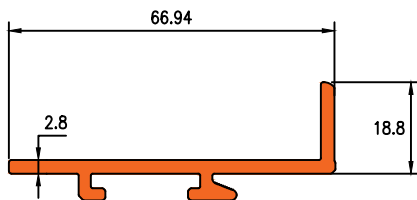

Die No. 21127

1.027 Kg/m

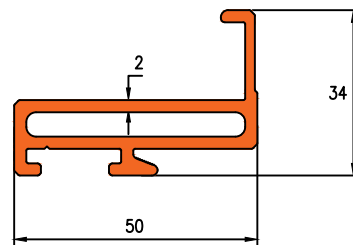

LIFT



Darshan Extrusions Pvt. Ltd.

Die No. 21128

1.060 Kg/m

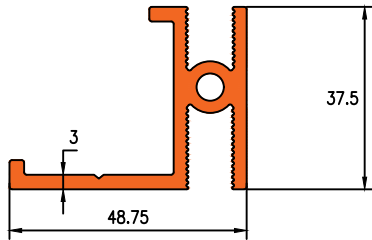

Die No. 21129

1.190 Kg/m

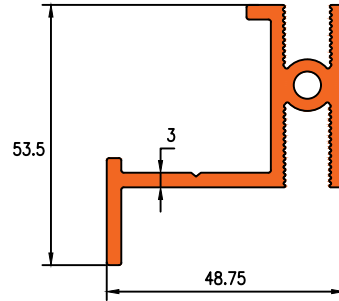

Die No. 21130

0.716 Kg/m

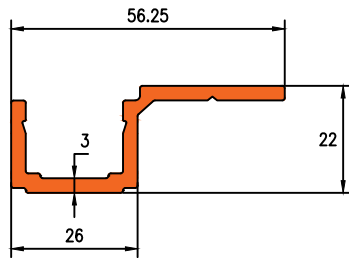

LIFT



Darshan Extrusions Pvt. Ltd.

Die No.16228

0.549KG/M

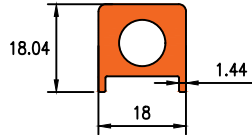

Die No. 19466

0.329KG/M

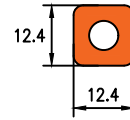

Die No.1255

4.112KG/M

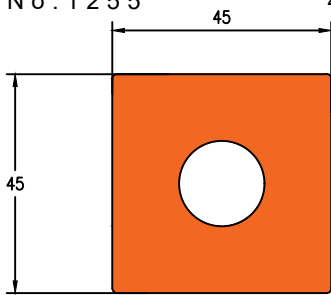

Die No.19115

2.273KG/M

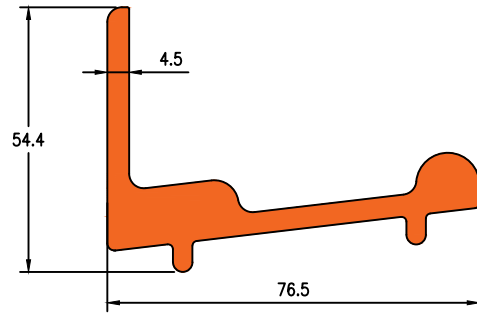

Die No.19108

7.133KG/M

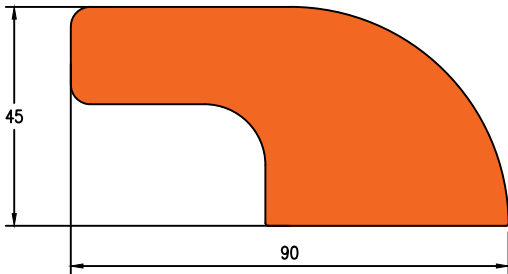

Die No.19114

2.663KG/M

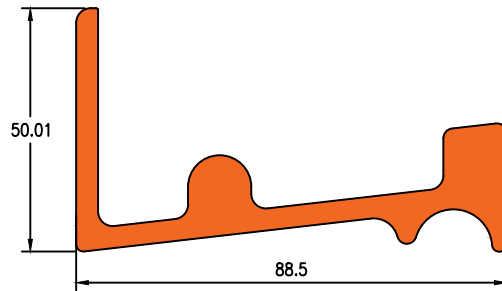

Die No.19017

7.255KG/M

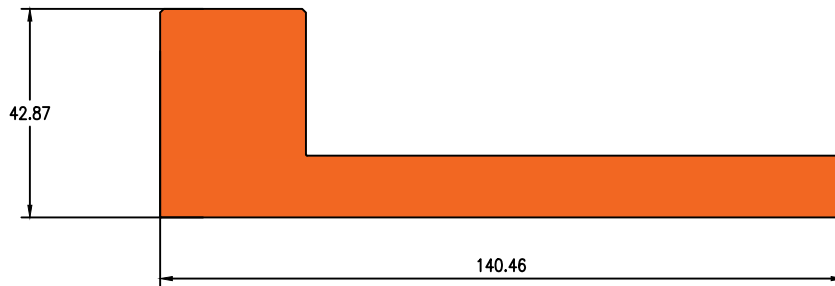

INDUSTRIAL



Darshan Extrusions Pvt. Ltd.

Die No. 19342

4.863KG/M

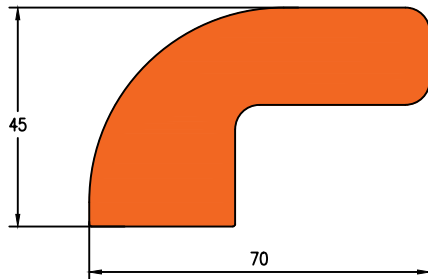

Die No.19095

2.283KG/M

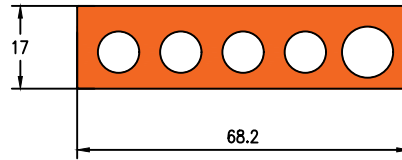

Die No.19096

4.020KG/M

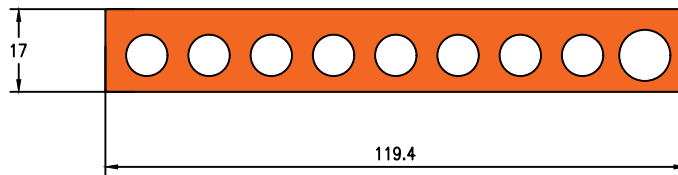

Die No. 19653

1.158KG/M

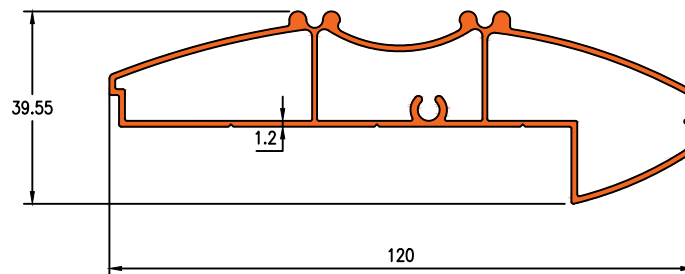

Die No.19035

3.003KG/M

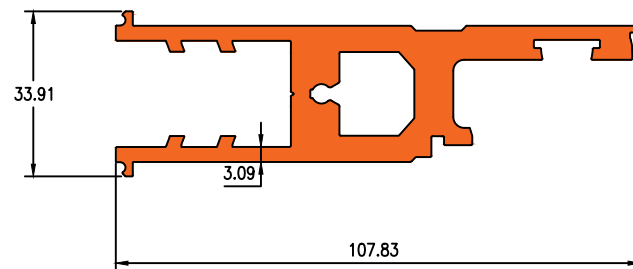

INDUSTRIAL



Darshan Extrusions Pvt. Ltd.

Die No.19090

3.175KG/M

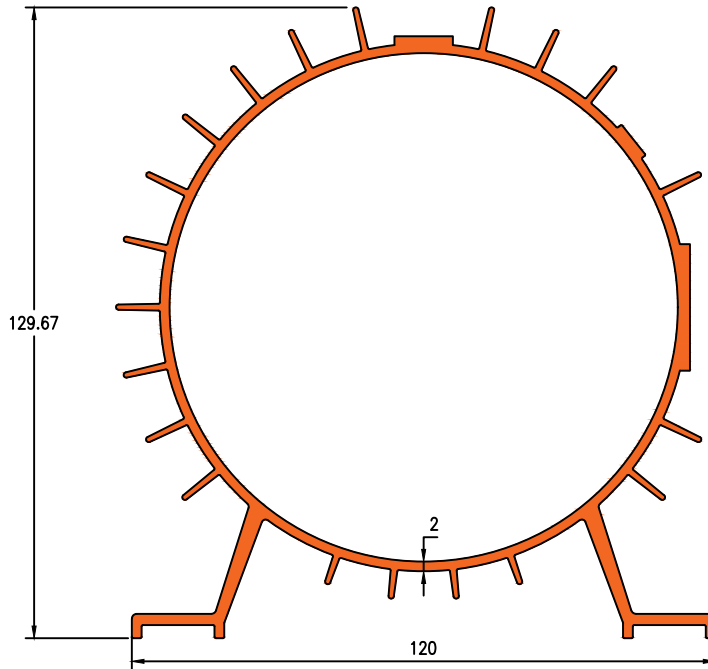

Die No. 16248

0.274KG/M

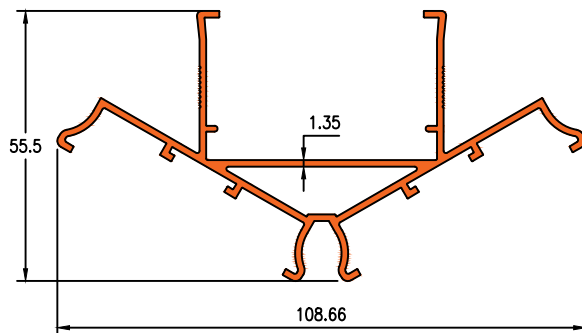

Die No. 19460

3.820KG/M

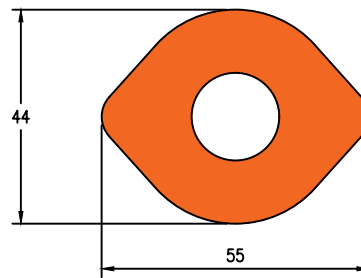

MOTOR BODY



Die No. 7096

1.601KG/M

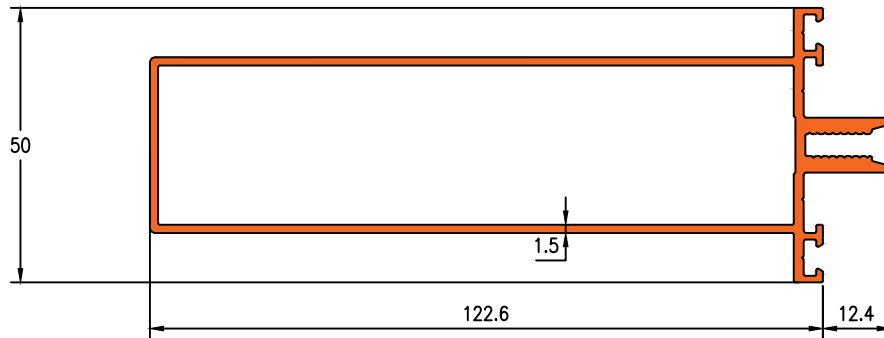

Die No. 7097

2.658KG/M

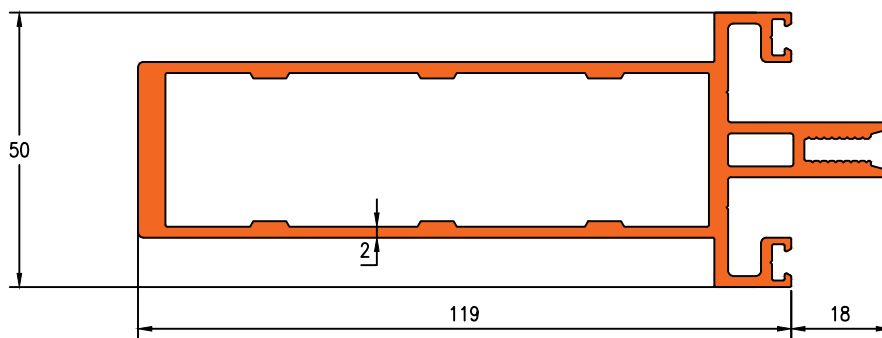

Die No. 16570

1.562KG/M

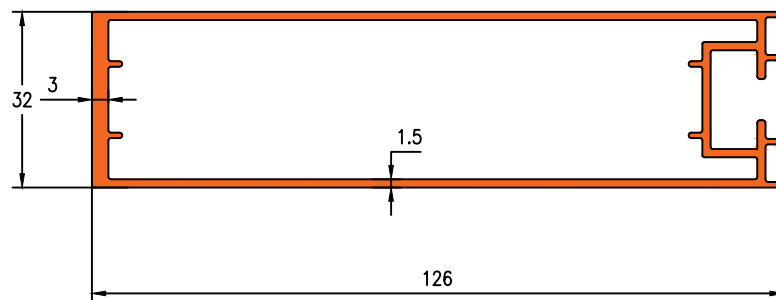



Die No. 19565

2.538KG/M

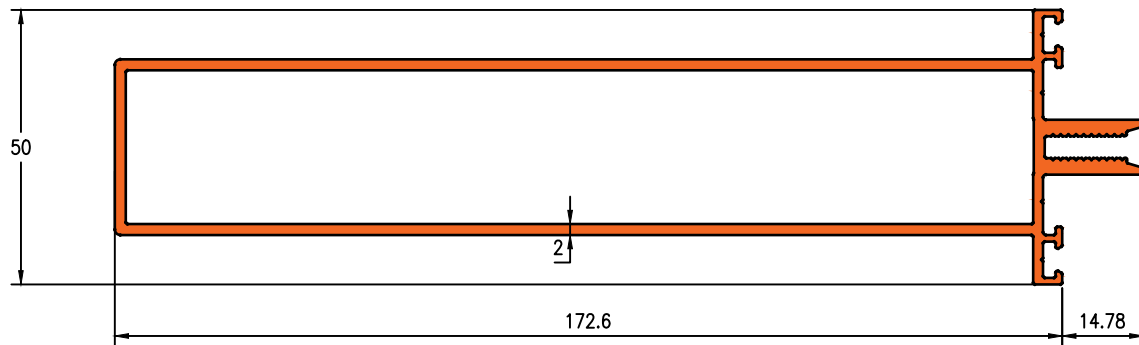

Die No. 19566

3.339KG/M

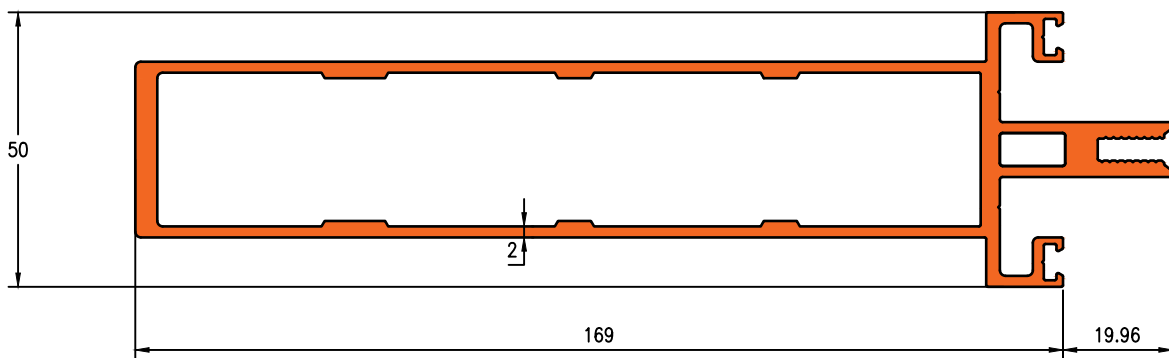

Die No. 19567

0.321KG/M

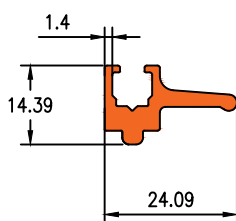



Die No. 21057

0.887KG/M

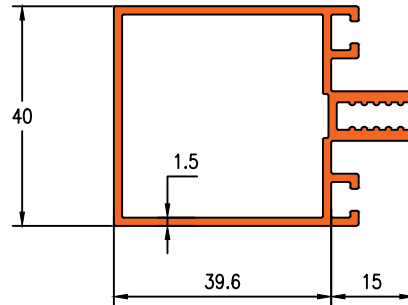

Die No. 21055

1.321KG/M

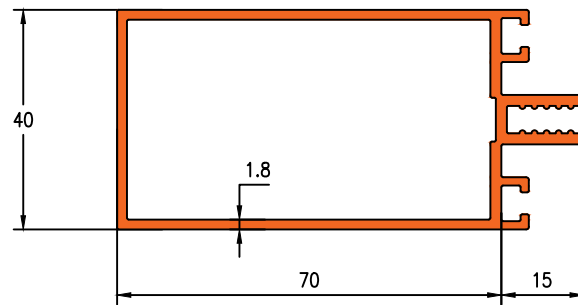

Die No. 21056

1.682KG/M

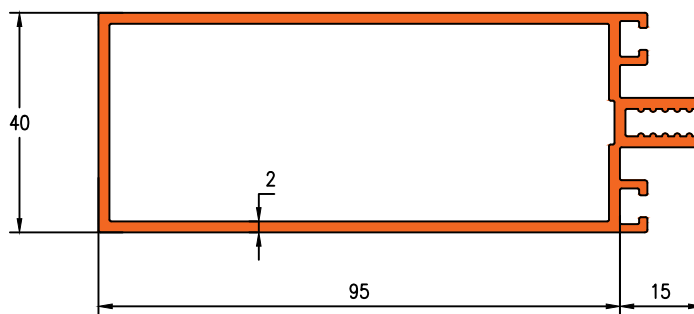



Die No. 19360

0.659KG/M

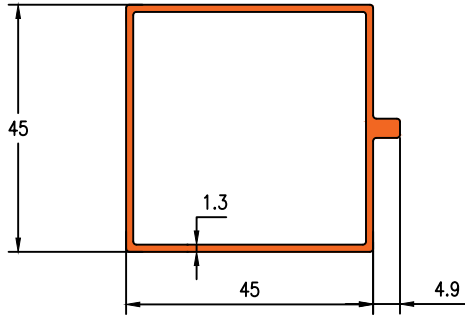

Die No. 19573

2.318KG/M

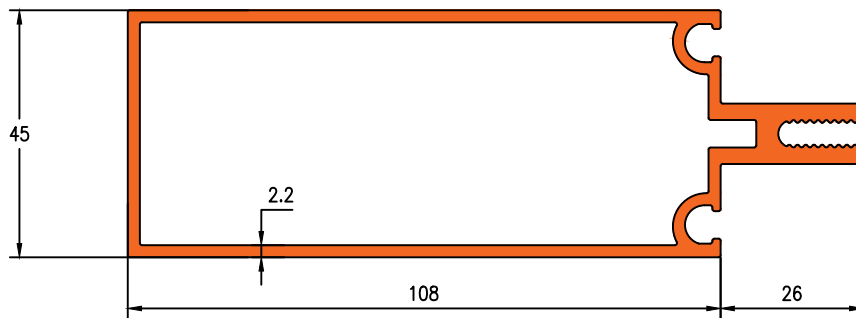



Die No. 27065

0.802KG/M

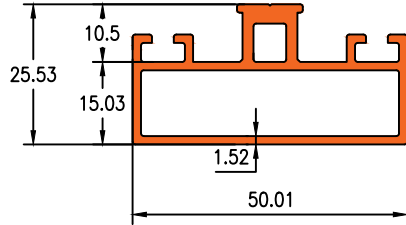

Die No. 19646

1.279KG/M

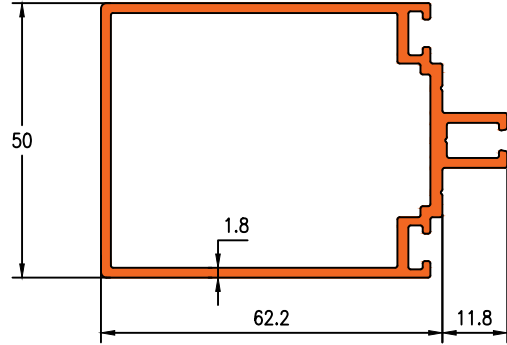

Die No. 19645

1.789KG/M

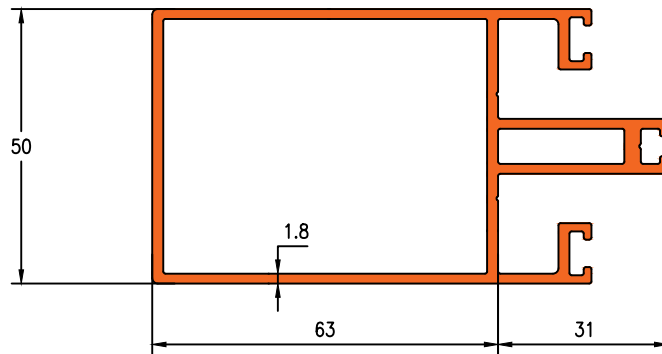

Die No. 7106

1.775Kg/m

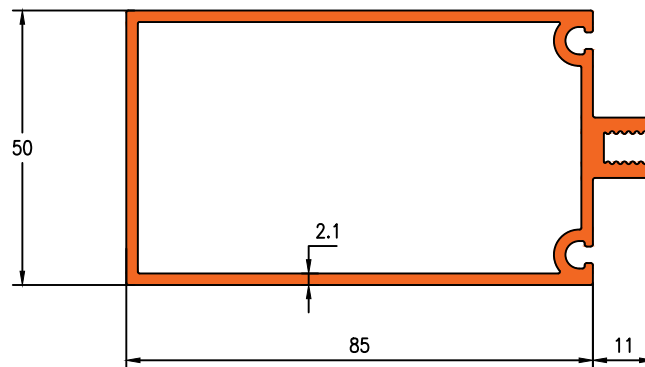



Die No. 9230

2.870KG/M

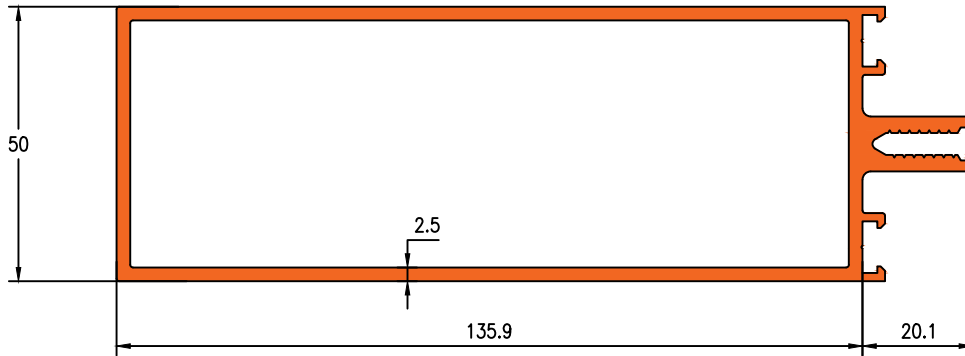

Die No. P60626

2.950KG/M

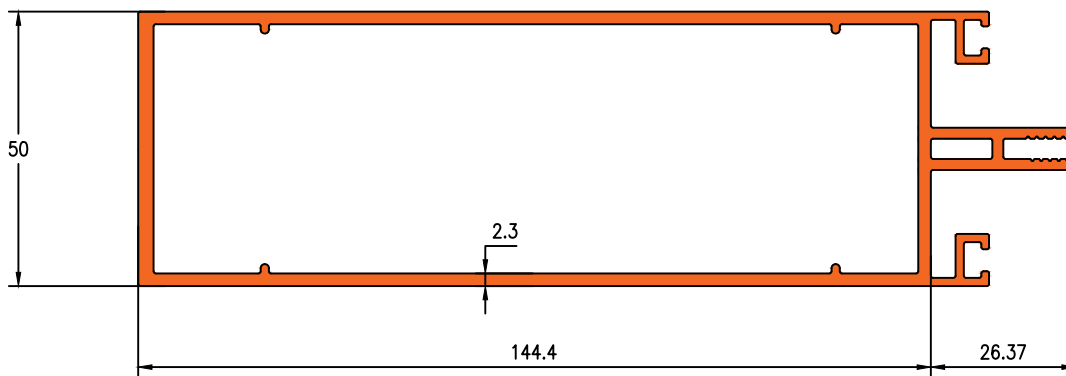

Die No. 16578

4.690KG/M

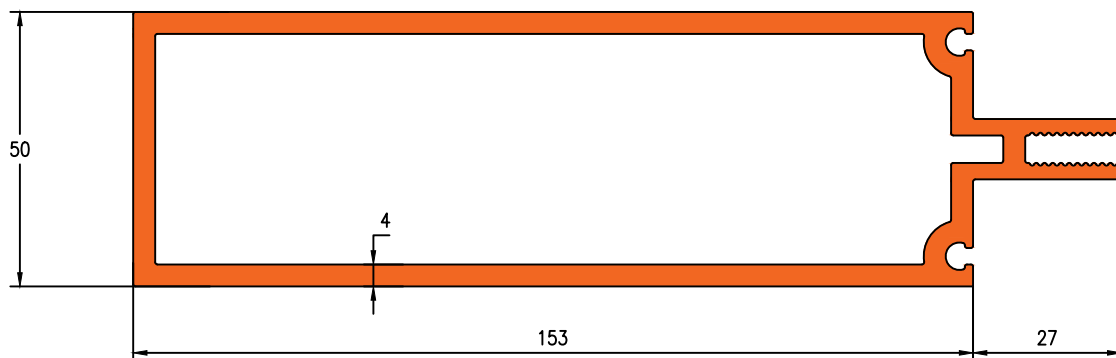



Die No. 27030

2.083KG/M

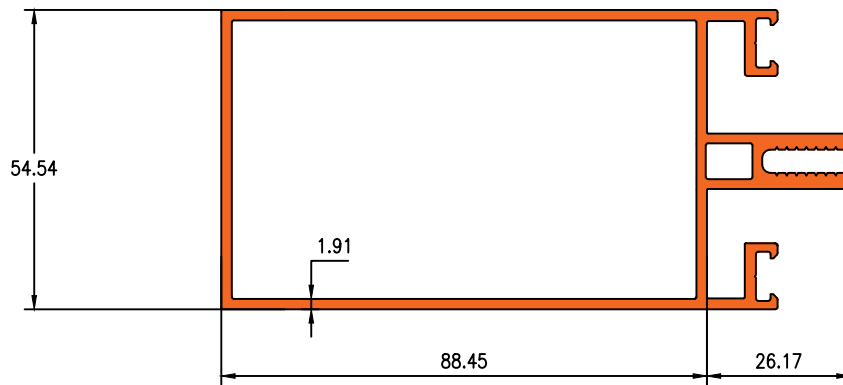

Die No. 19413

1.617KG/M

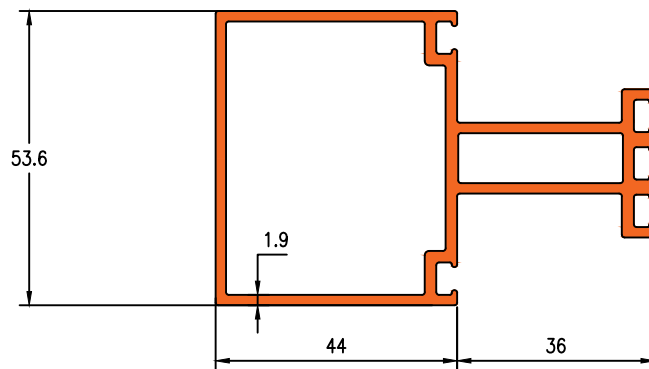



Die No.20008

1.514KG/M

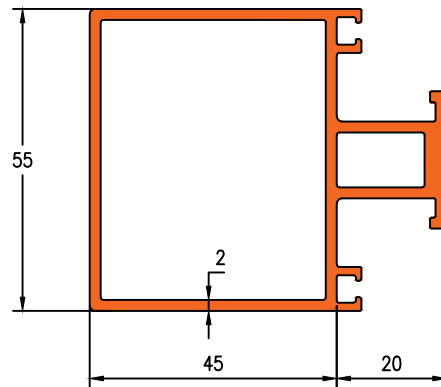

Die No. 27029

1.321KG/M

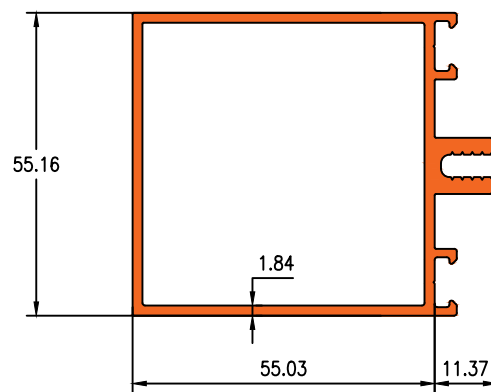

Die No. 20002

1.683KG/M

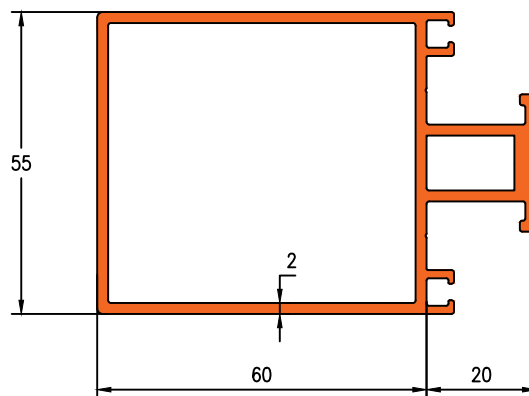

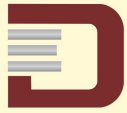

Die No. 28136

1.620KG/M

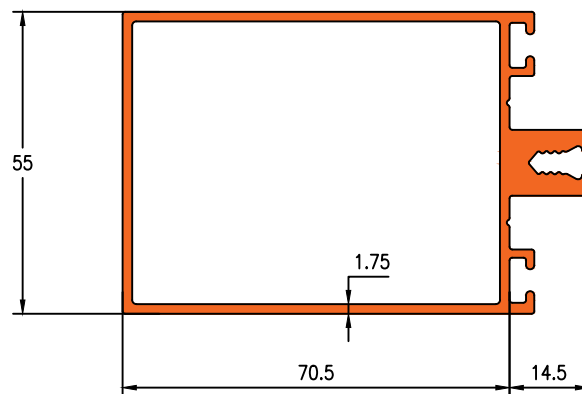

Die No.20007

1.898KG/M

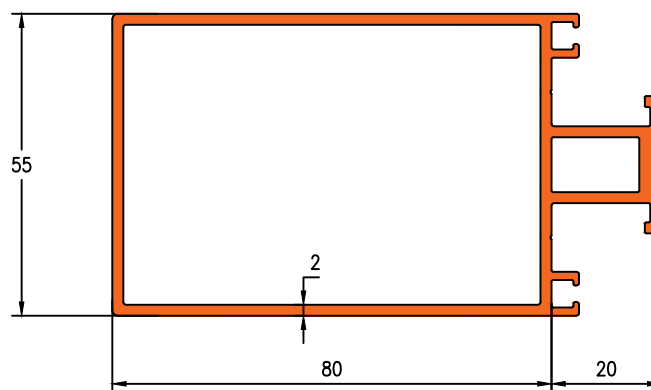

Die No.16238

2.413KG/M

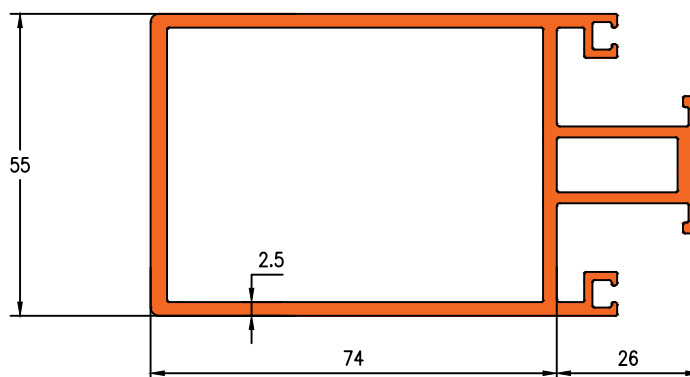



Die No.19414

2.432KG/M

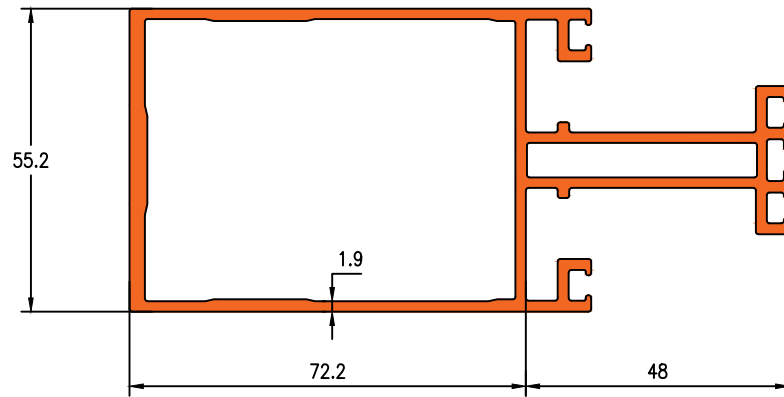

Die No. 28135

2.007KG/M

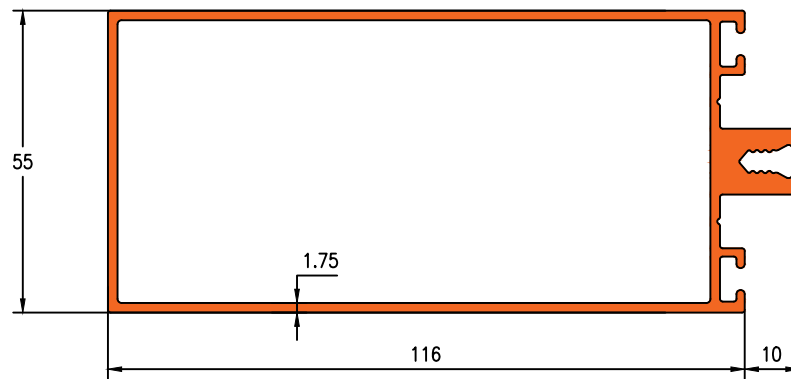

Die No. 28134

2.530KG/M

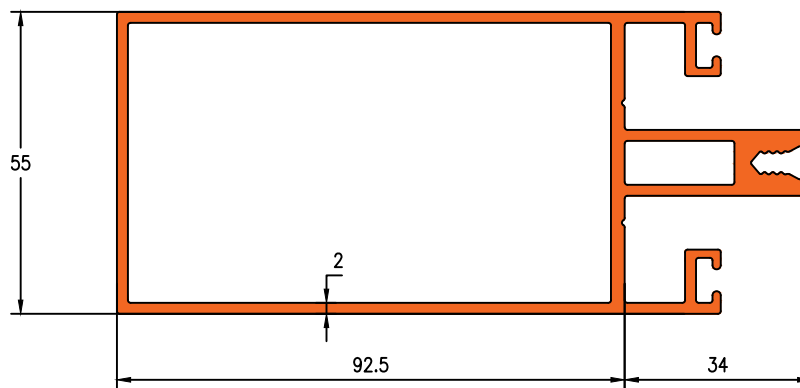



Die No. 20001

2.470KG/M

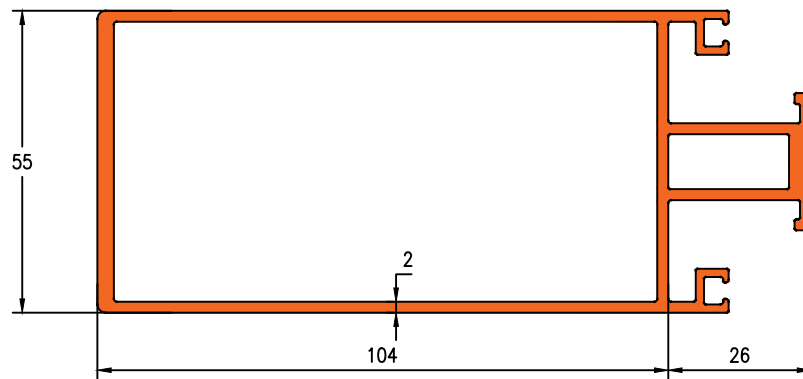

Die No.20006

2.740KG/M

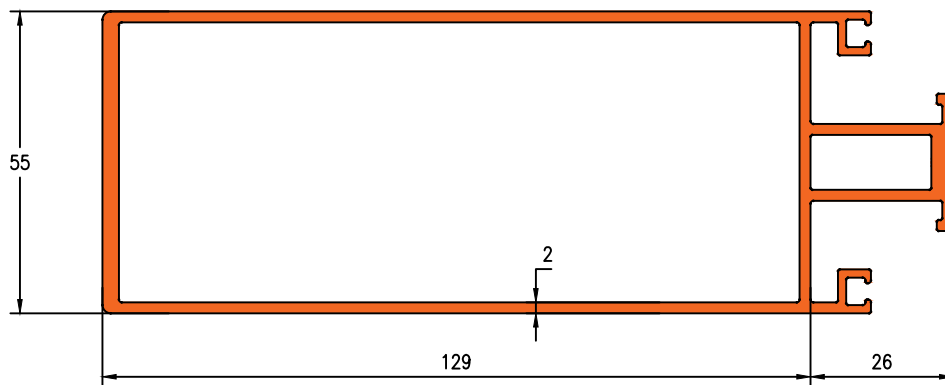

Die No.P61362

2.743KG/M

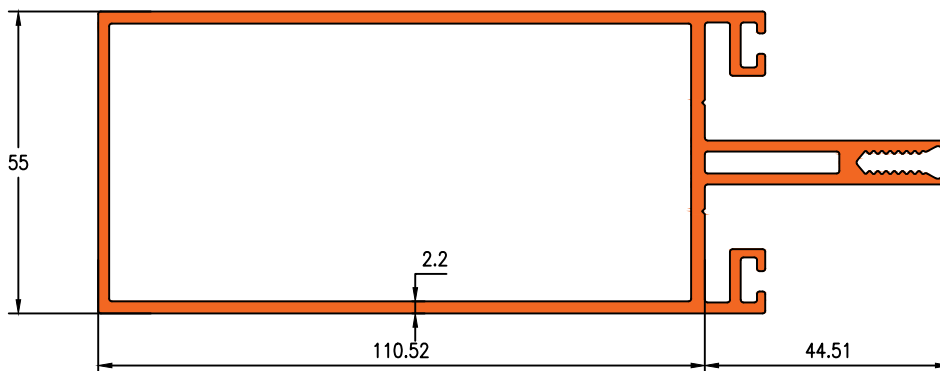



Die No.19424

1.326KG/M

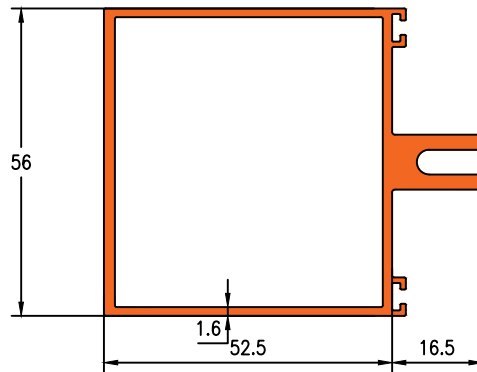

Die No. 19423

2.671KG/M

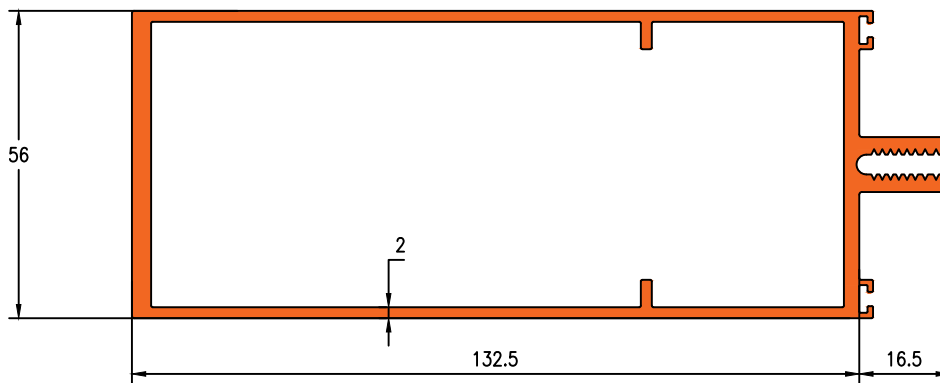

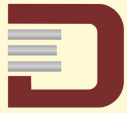

Die No. 27008

1.520KG/M

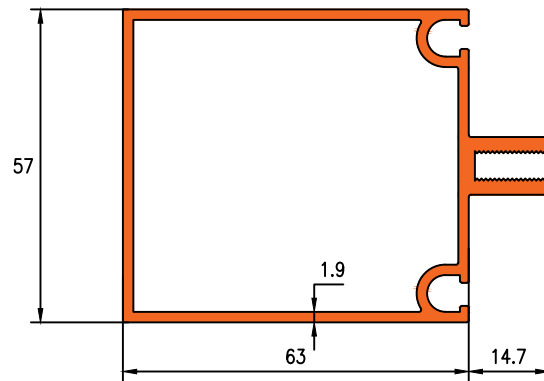

Die No. 27009

2.158KG/M

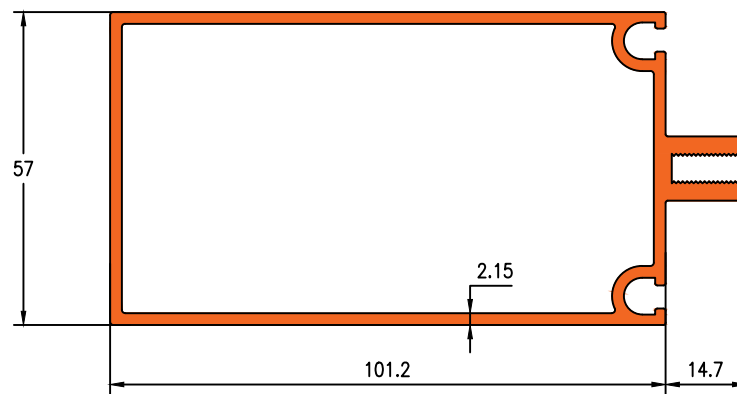

Die No. 16214

1.370KG/M

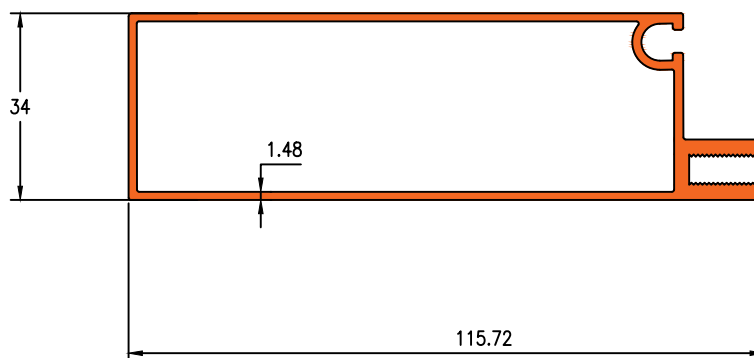



Die No. 27010

3.070KG/M

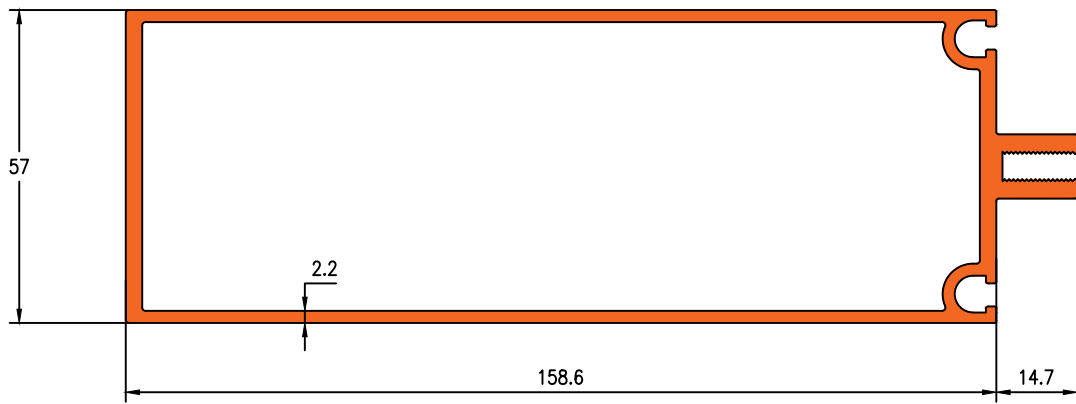



Die No. 1392

2.020KG/M

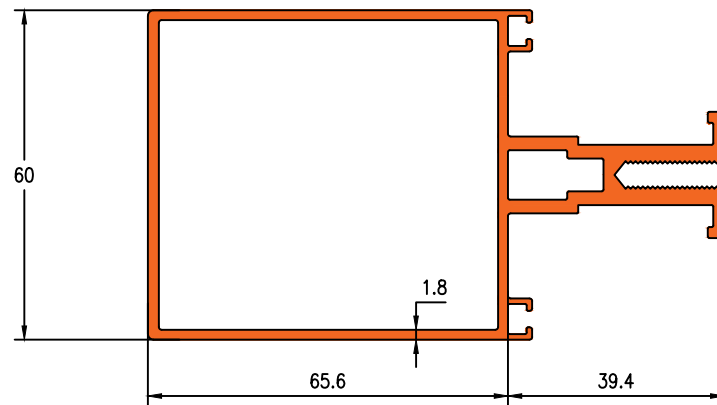

Die No. 2820

2.486KG/M

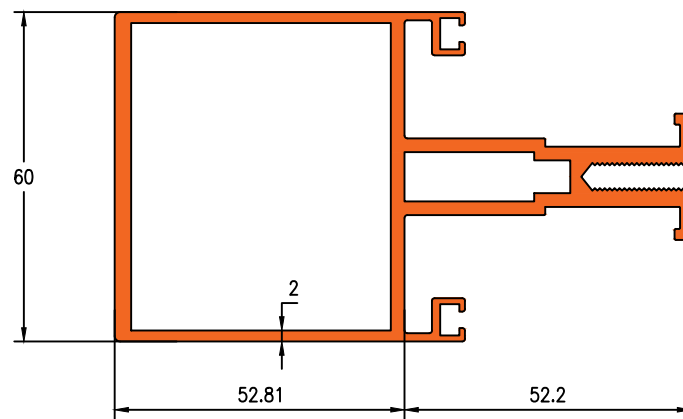

Die No. P70633

1.832KG/M

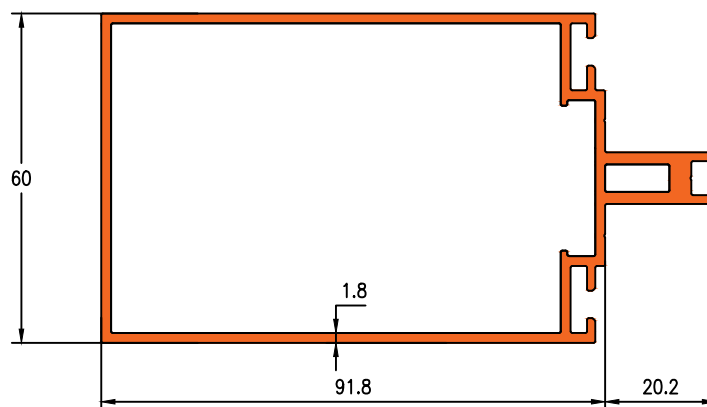



Die No. 1400

3.025KG/M

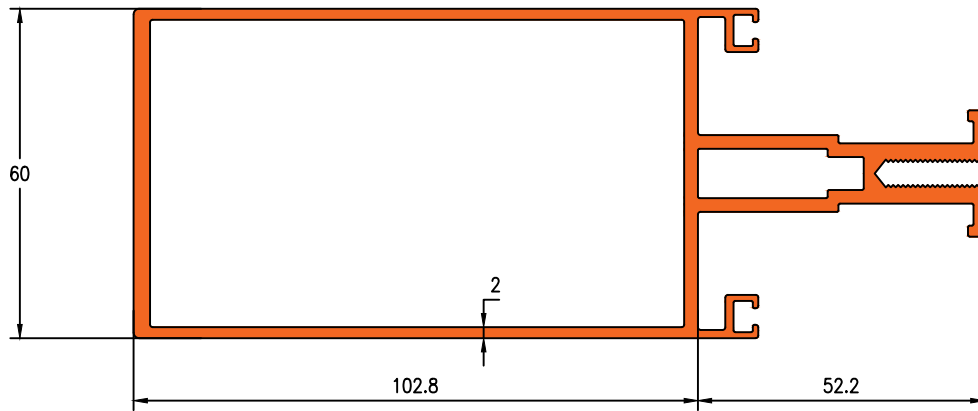

Die No. 19998

3.008KG/M

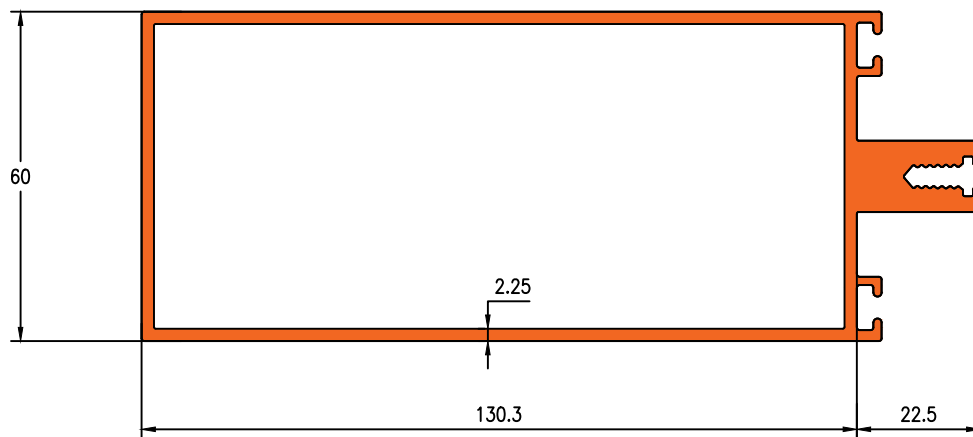

Die No. 19557

2.774KG/M

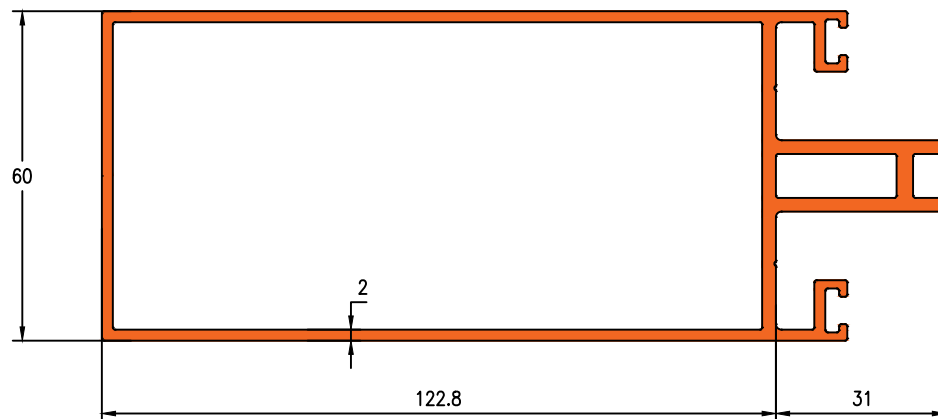



Die No. 19558

2.442 Kg/m

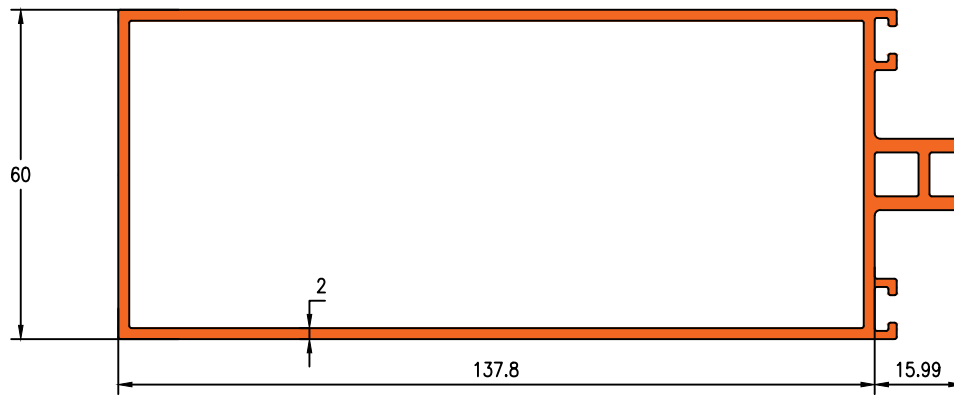

Die No. 19410

3.178 Kg/m

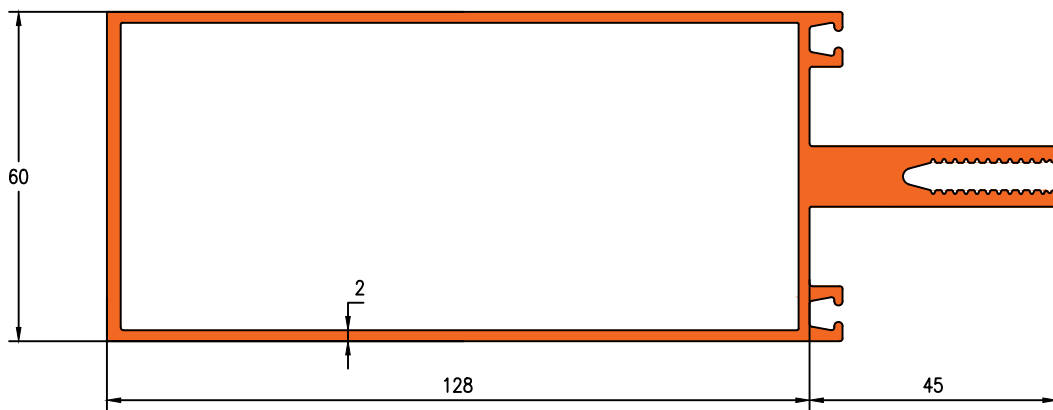

Die No. 19409

3.189 Kg/m

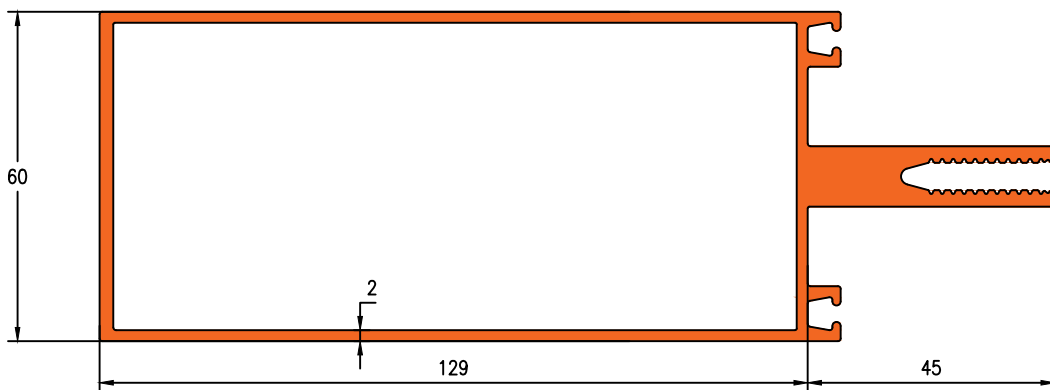



Die No. P70631

3.331 Kg/m

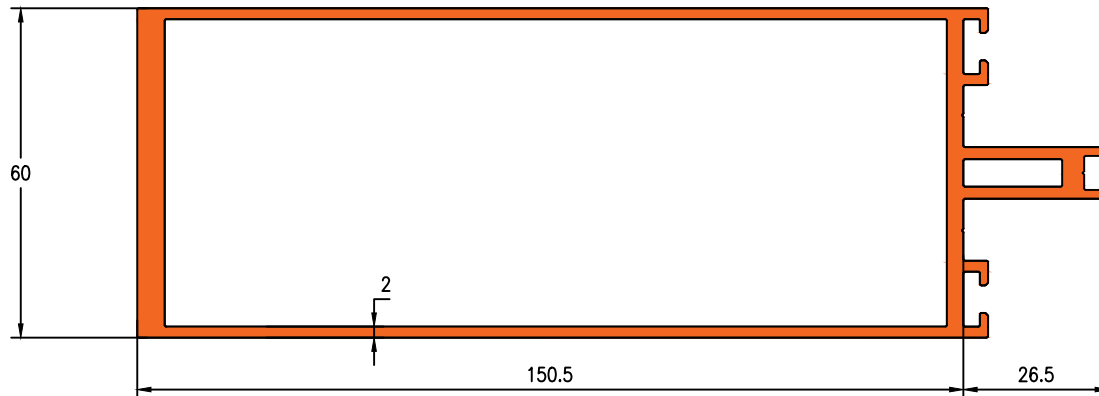

Die No. P71240

2.762 Kg/m

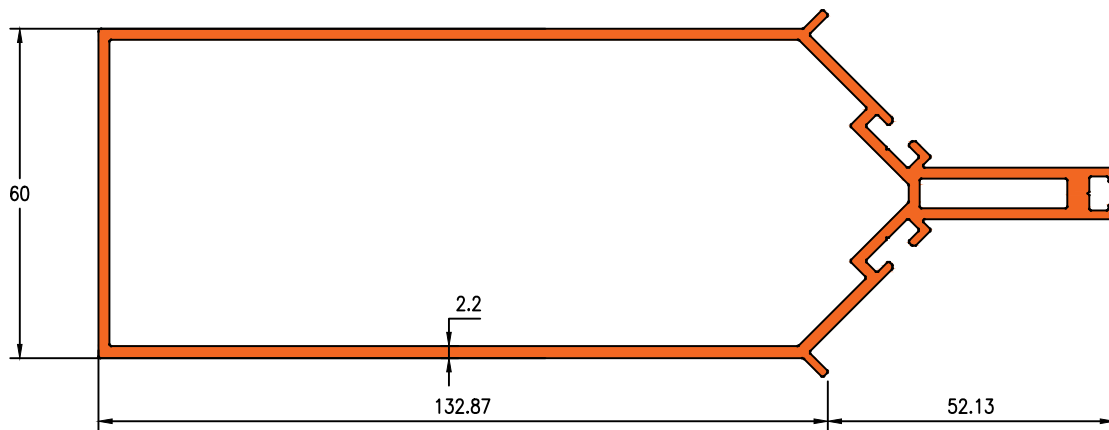

Die No. 19555

3.364 Kg/m

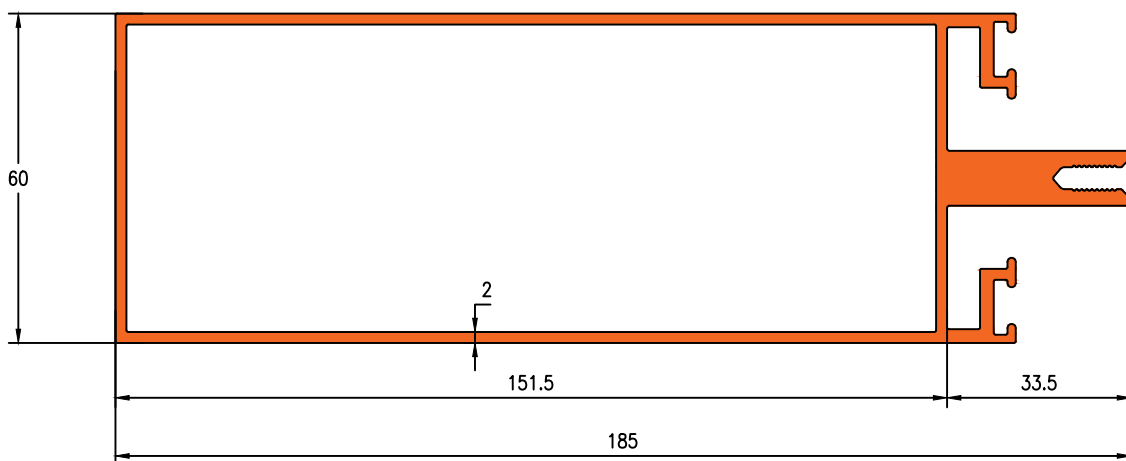



Die No. 20010

3.539Kg/m

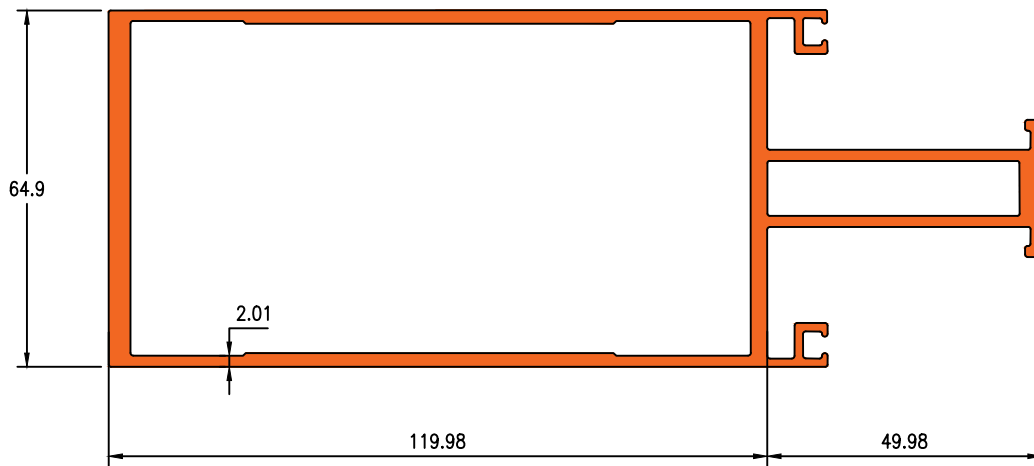

Die No. 20013

2.740Kg/m

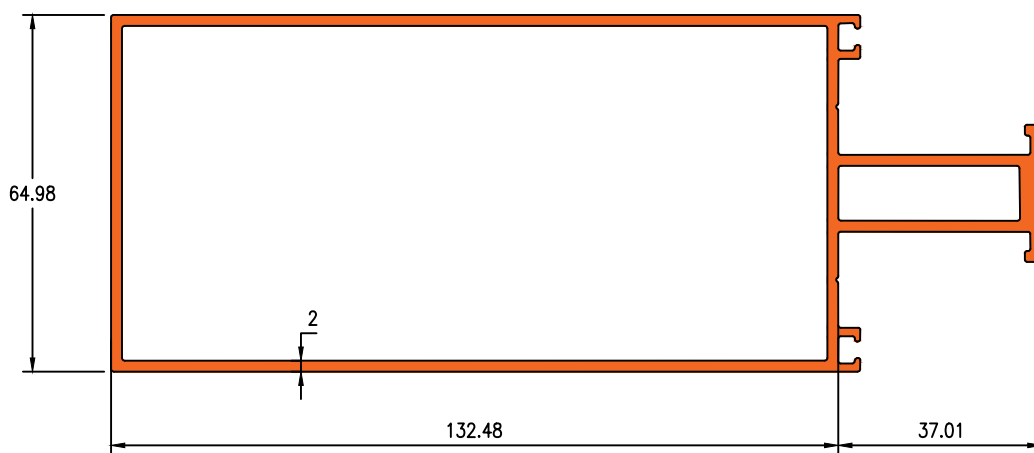

Die No. 20011

1.970Kg/m

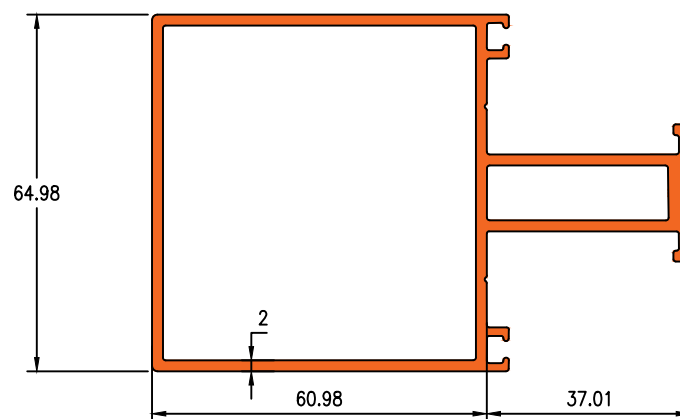



Die No. 28214

1.661Kg/m

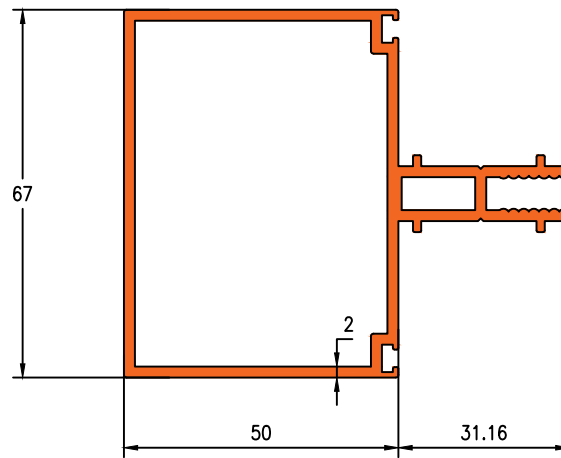

Die No. 27016

1.210Kg/m

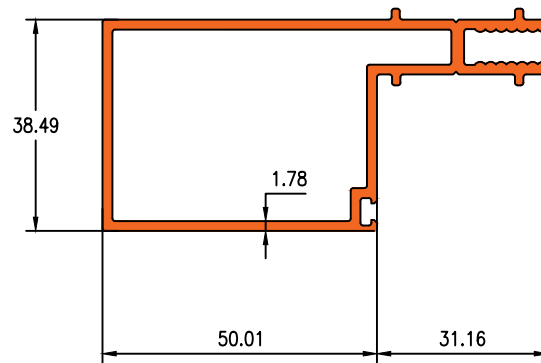

Die No.19470

1.821Kg/m

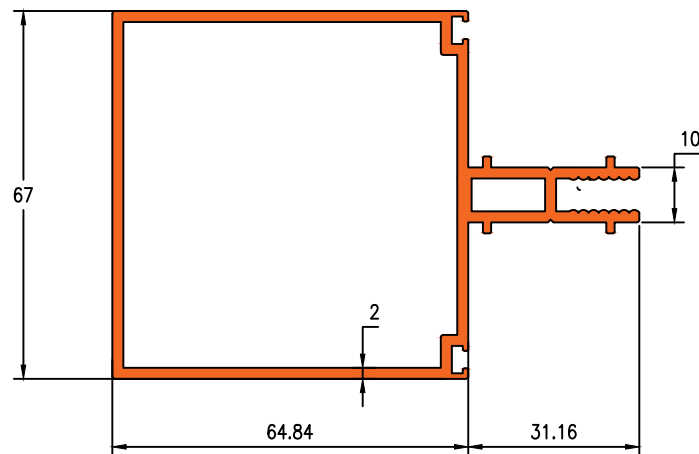



Die No. 16530

1.496Kg/m

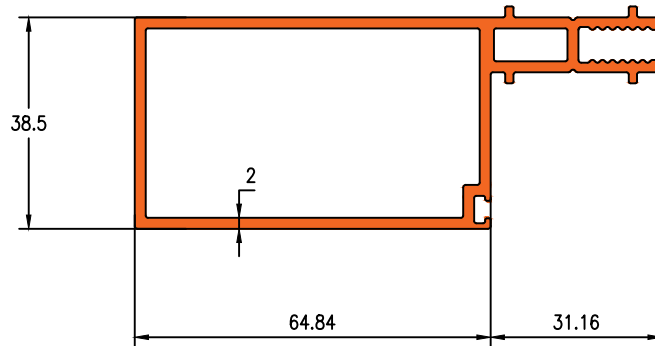

Die No. 27014

2.393Kg/m

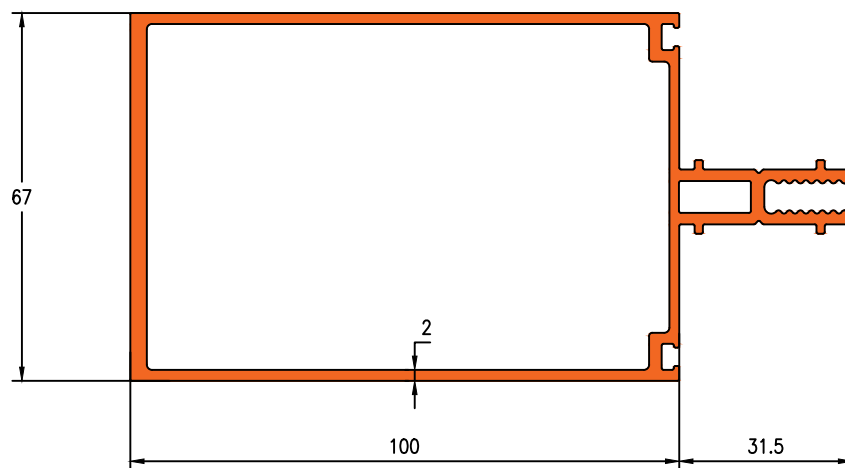

Die No. 27015

1.730Kg/m

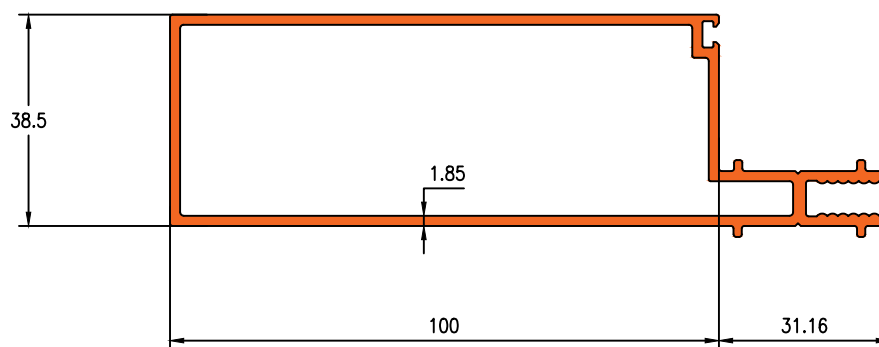



Die No.P61267

2.535Kg/m

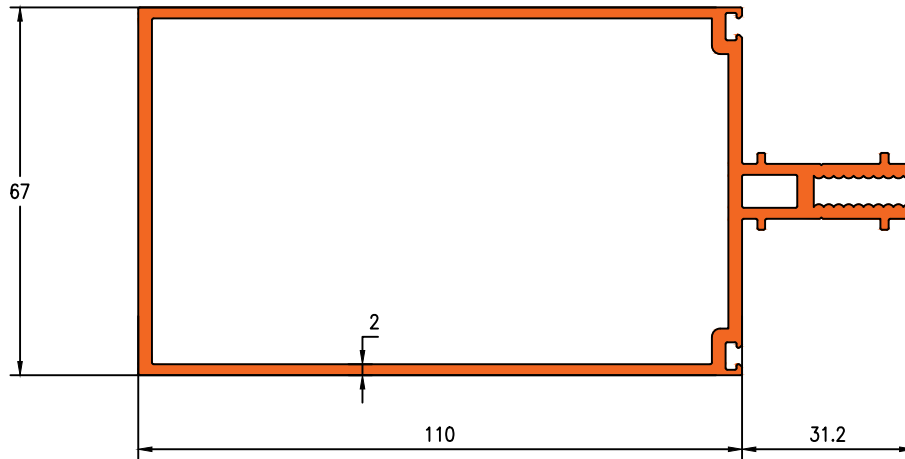

Die No.P61301

2.514Kg/m

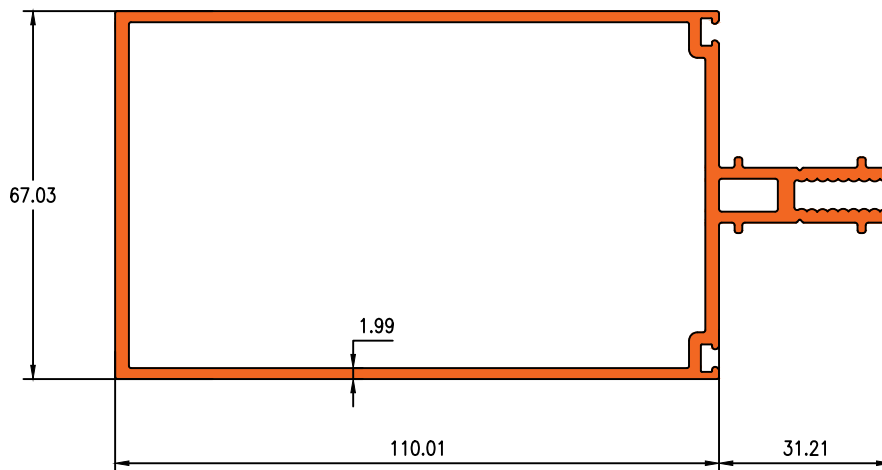

Die No.4094

2.968Kg/m

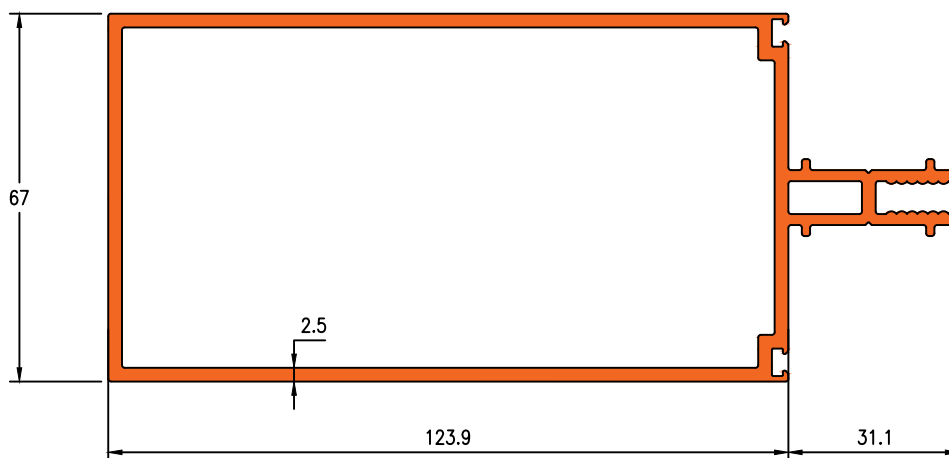



Die No. P61303

2.913Kg/m

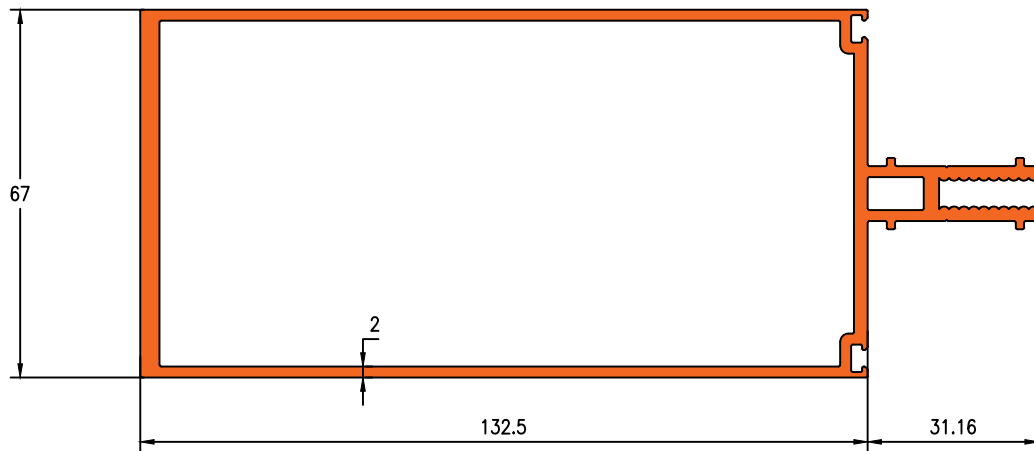

Die No. P60286

2.979Kg/m

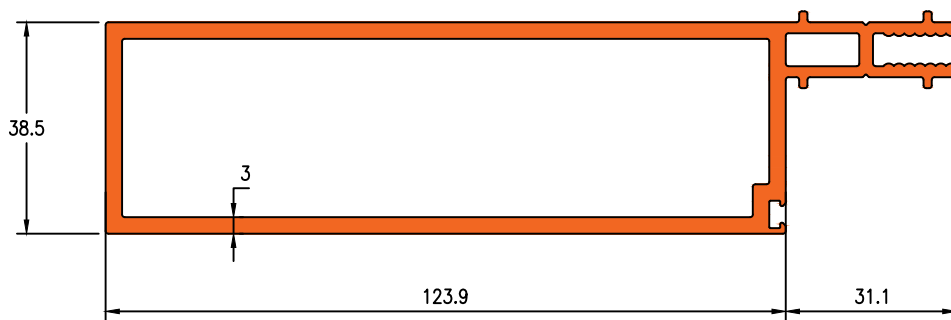

Die No. 19554

2.842Kg/m

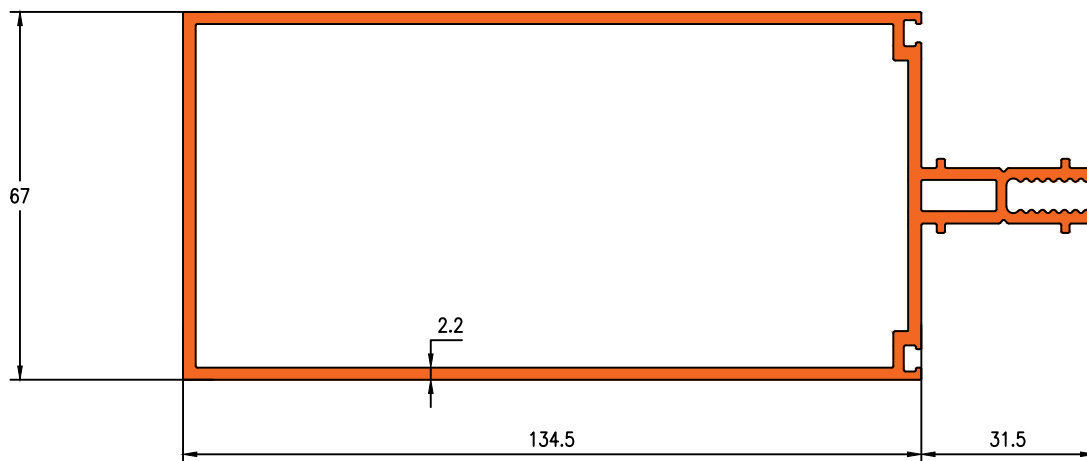

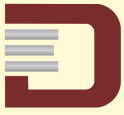

Die No. 19563

5.862Kg/m

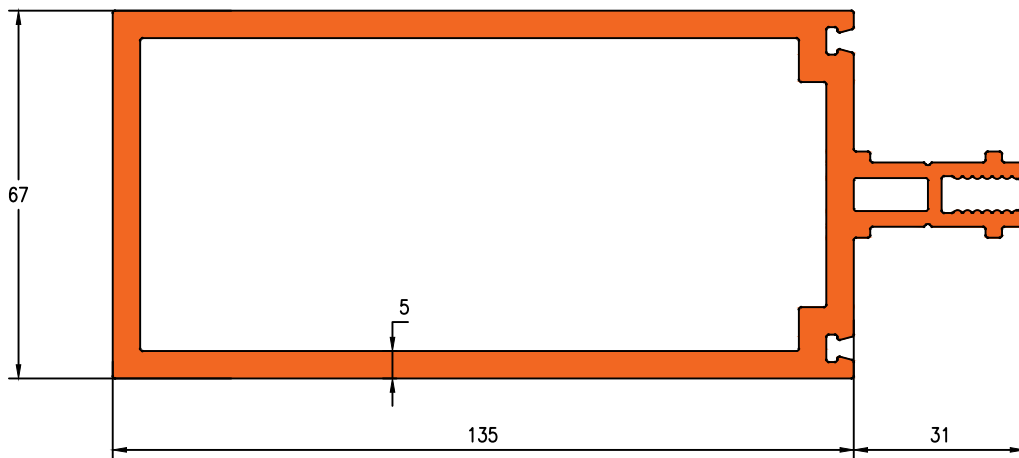

Die No. 28149

1.237KG/M

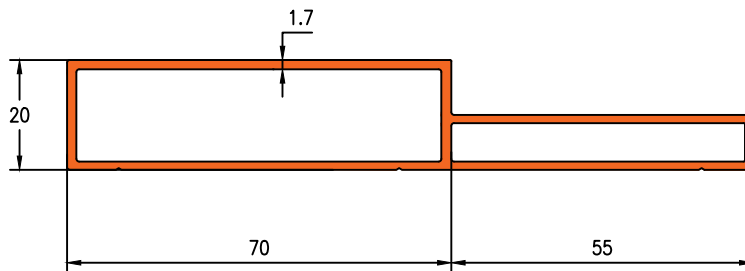

Die No. 28156

1.148KG/M

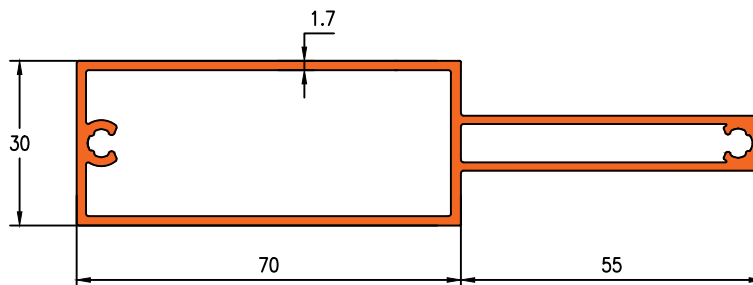



Die No. 1208

1.292 Kg/m

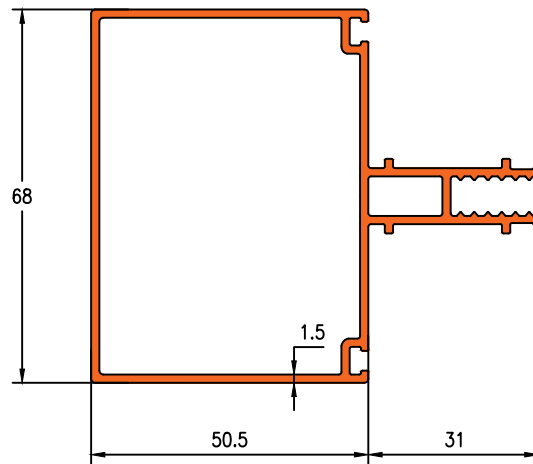

Die No. 27013

3.546 Kg/m

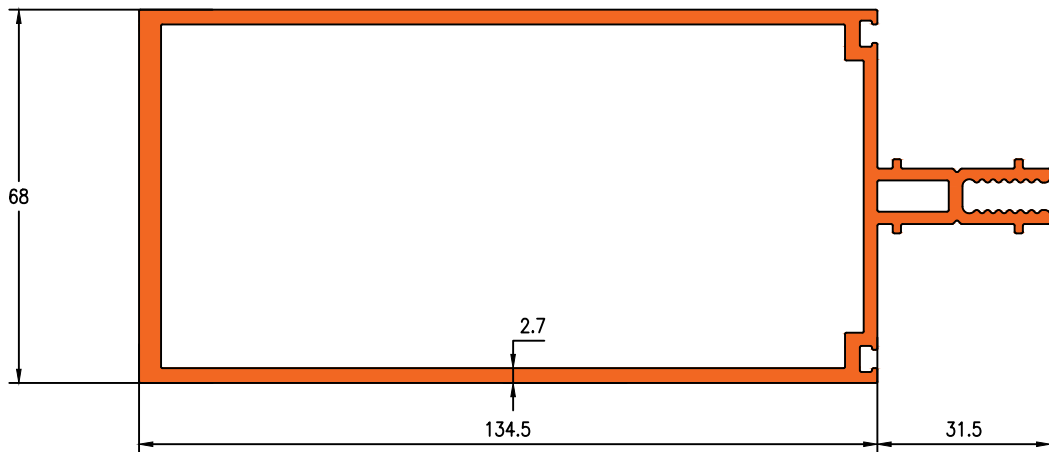



Die No. 7071

1.184Kg/m

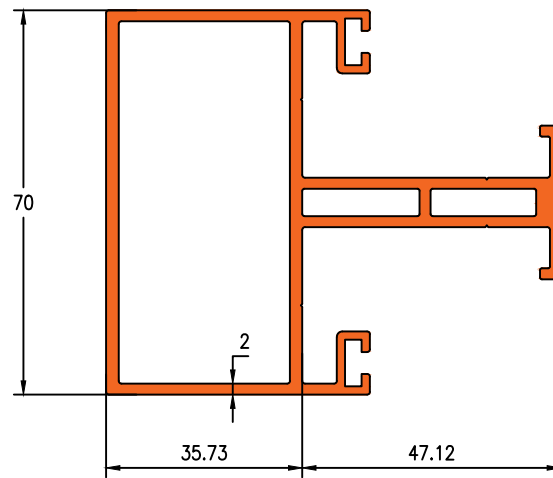

Die No. 7074

1.667Kg/m

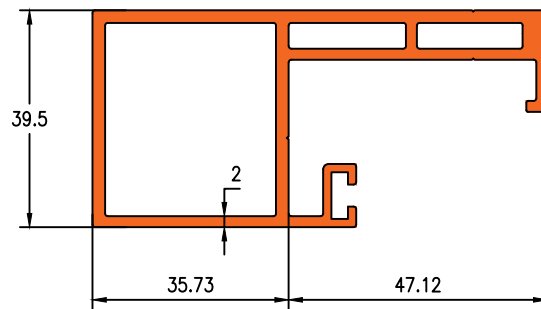

Die No. 7072

2.062Kg/m

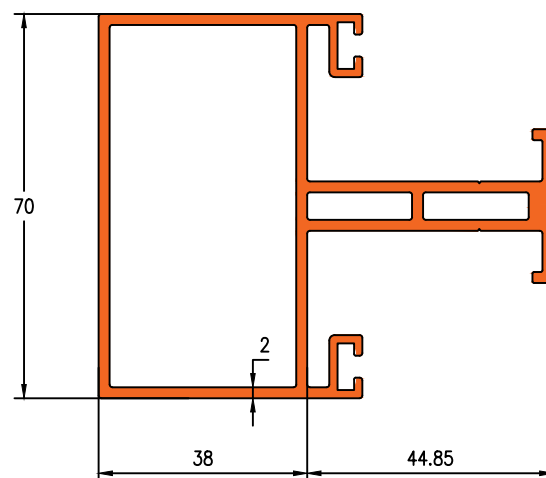



Die No.7073

1.609Kg/m

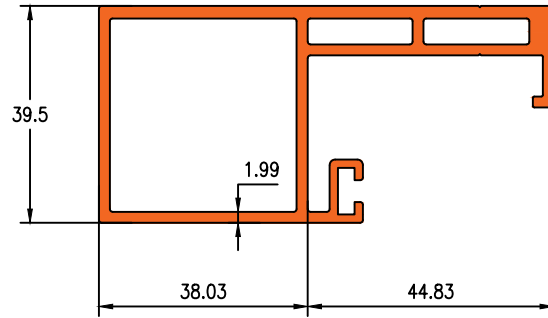

Die No.16668

1.601Kg/m

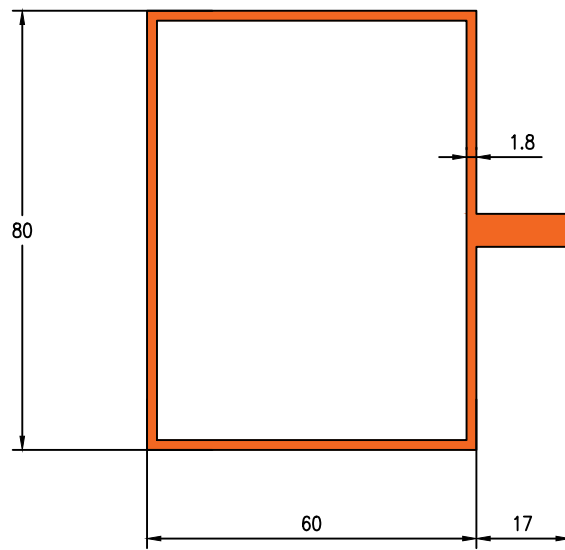

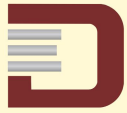

Die No. 16571

0.320Kg/m

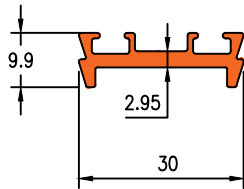

Die No. 16572

0.221Kg/m

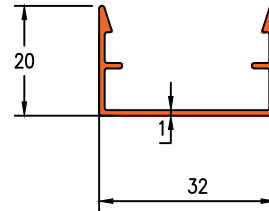

Die No. 21244

0.256Kg/m

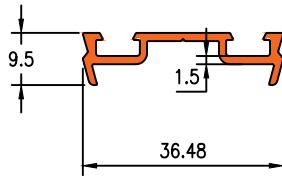

Die No. 21243

0.283Kg/m

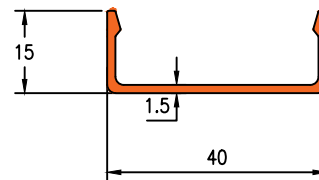

Die No. 2851

0.877Kg/m

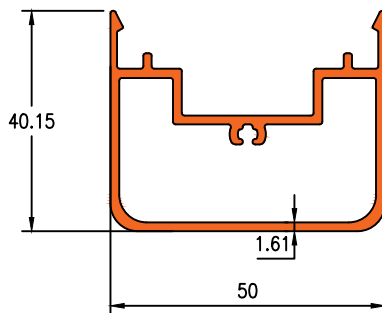

Die No. 2850

0.468Kg/m

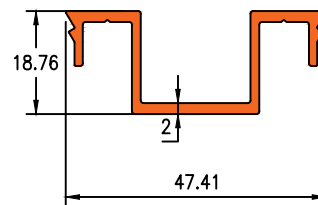

Die No. 1353

0.381Kg/m

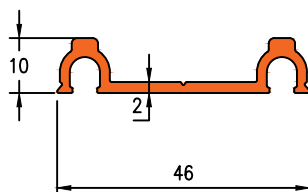

Die No. 1354

0.302Kg/m

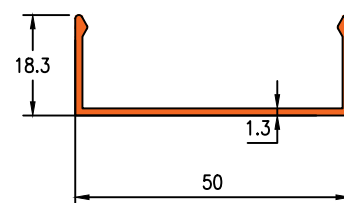

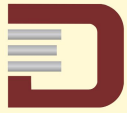

Die No. 7078

0.307Kg/m

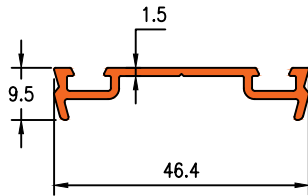

Die No. 7075

0.323Kg/m

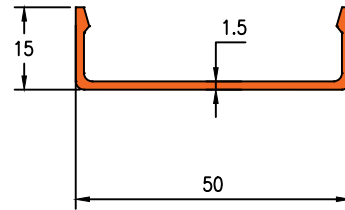

Die No. 28139

0.545Kg/m

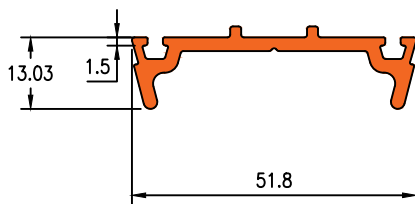

Die No. 28138

0.383Kg/m

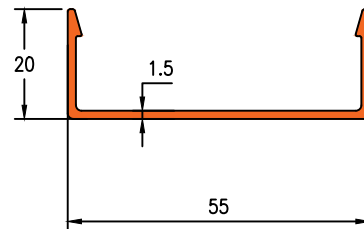

Die No. 27011

0.395Kg/m

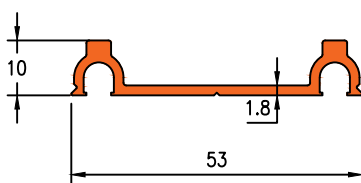

Die No. 27012

0.335Kg/m

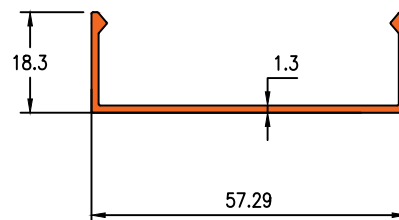

Die No. 20100

0.558Kg/m

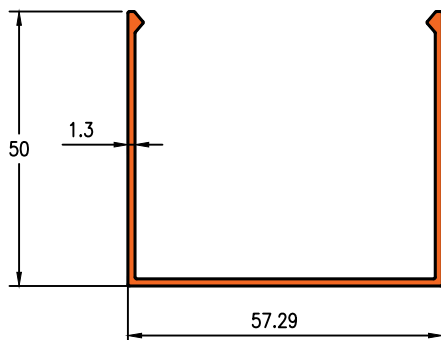

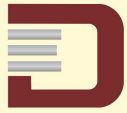

Die No. 16661

0.435Kg/m

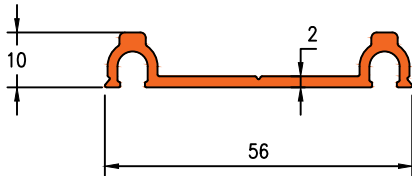

Die No. 16662

0.337Kg/m

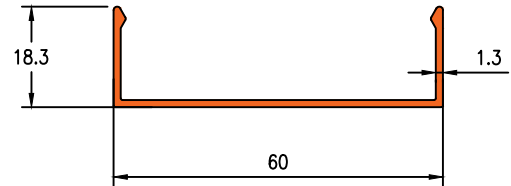

Die No. 23021

0.604Kg/m

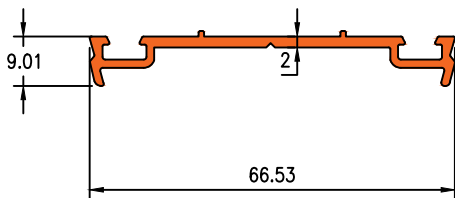

Die No. 23022

0.429Kg/m

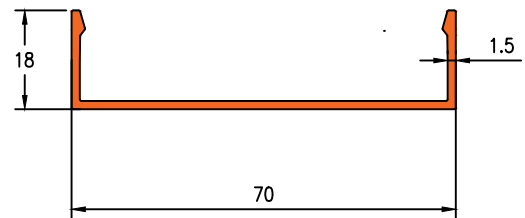

Die No. 19975

1.515Kg/m

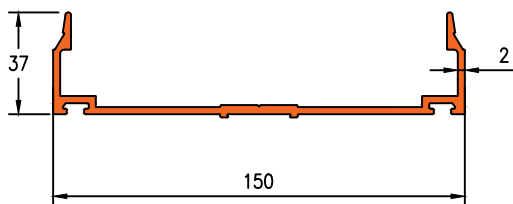

Die No. 19976

1.334Kg/m

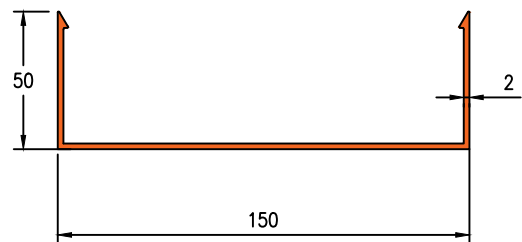

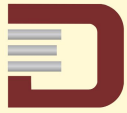

Die No. 1381

0.600Kg/m

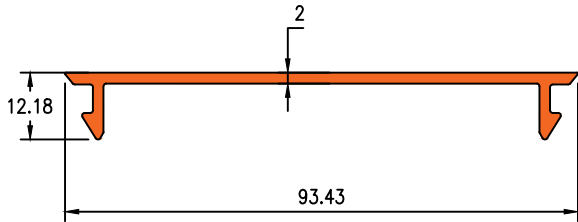

Die No. 1380

1.174Kg/m

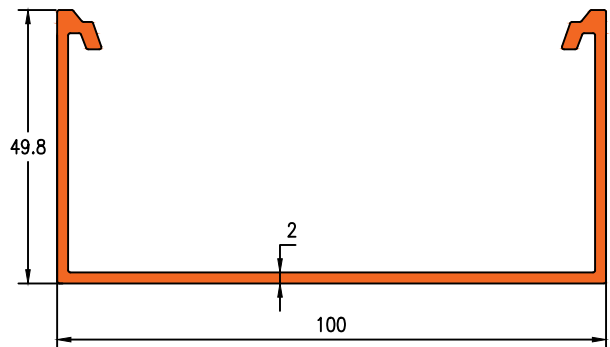

Die No. 7139

0.736 Kg/m

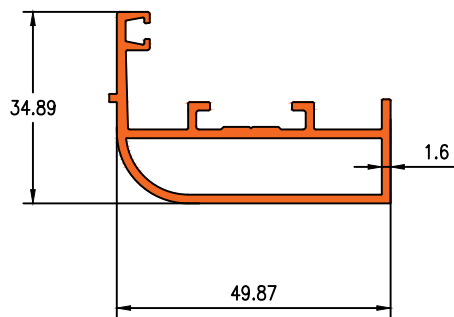

Die No. 28140

1.045Kg/m

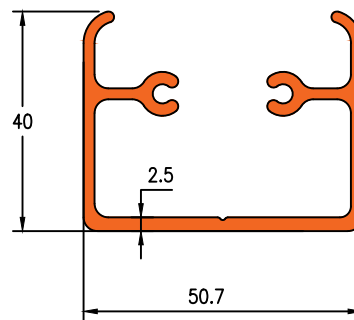

Die No. 19411

1.101 Kg/m

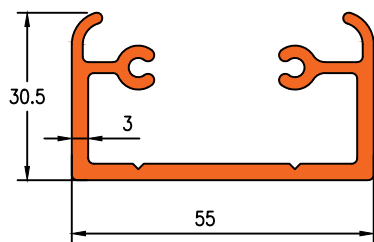

Die No. 21026

1.310Kg/m

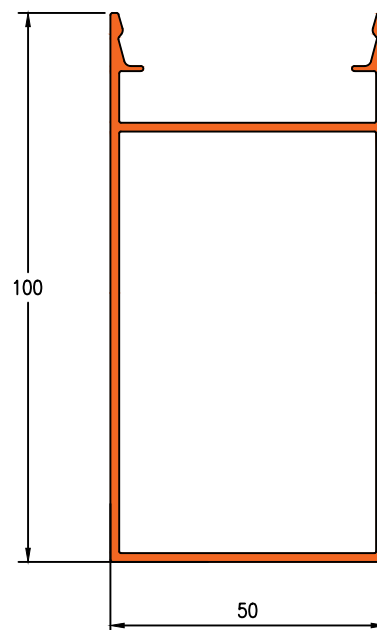

Die No. 21025

0.689 Kg/m

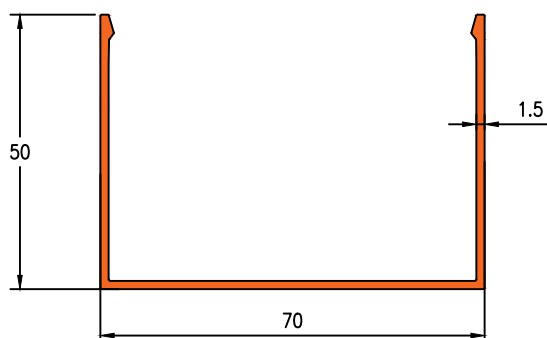

Clip :-Die No. 23021

Clip :-Die No. 7078



Die No. 7046

0.549 Kg/m

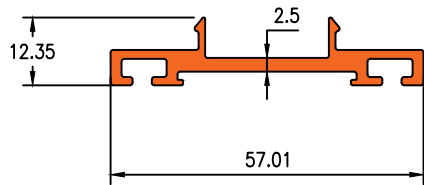

Die No. 7047

0.189 Kg/m

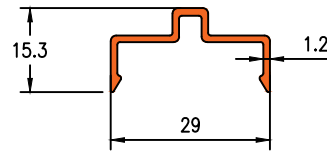



Die No.19396

0.427Kg/m

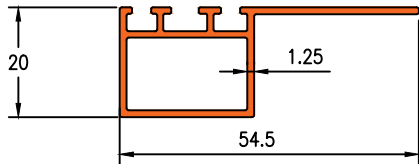

TOGGLE : 16159

Die No.19397

0.500Kg/m

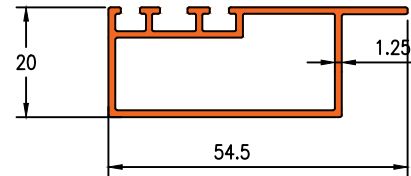

Die No.19412

0.597Kg/m

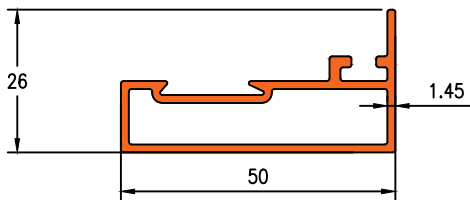

Die No.19425

0.465Kg/m

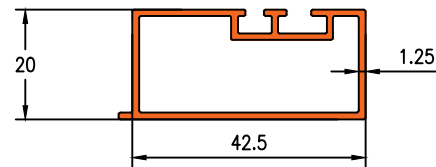

Die No.19609

0.814Kg/m

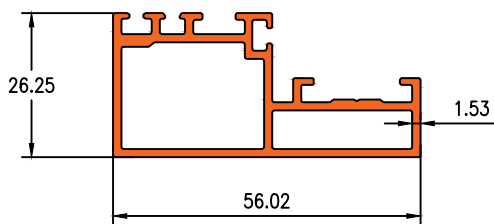

Die No.10202

0.662Kg/m

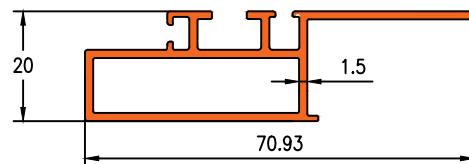

TOGGLE : 7077

Die No.28213

0.518Kg/m

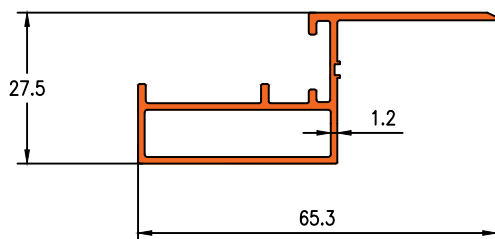

Die No.20052

0.583Kg/m

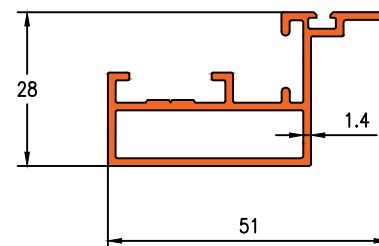



Die No.19465

0.735Kg/m

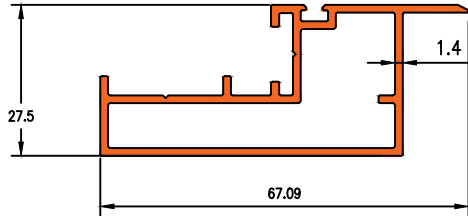

TOGGLE : 1232

Die No.19491

1.295Kg/m

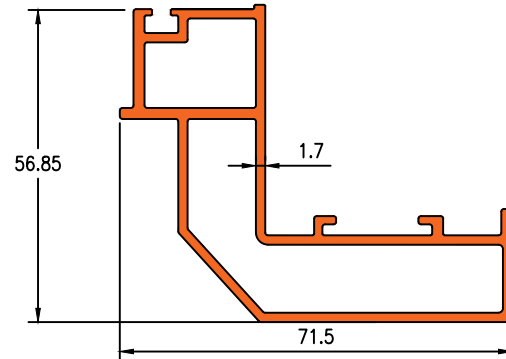

Die No.23008

0.539Kg/m

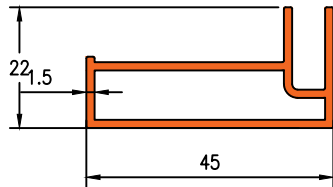

Die No. 1394

0.679Kg/m

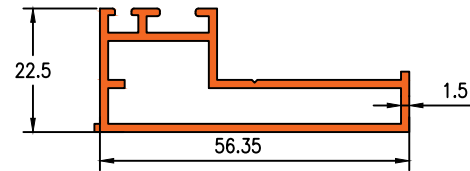

TOGGLE : 7077

Die No. 1395

0.819Kg/m

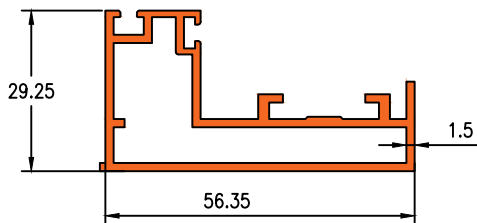

Die No. 1207

0.548Kg/m

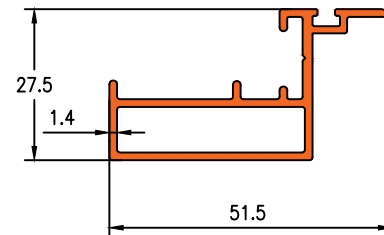

TOGGLE : 1232

Die No. 7076

0.846Kg/m

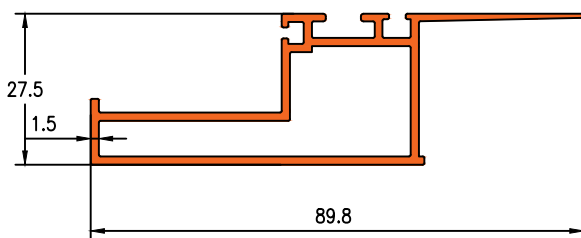

TOGGLE : 1396

Die No. 1231

0.444Kg/m

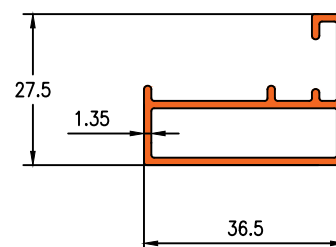

TOGGLE : 1232



Die No. 1393

0.842Kg/m

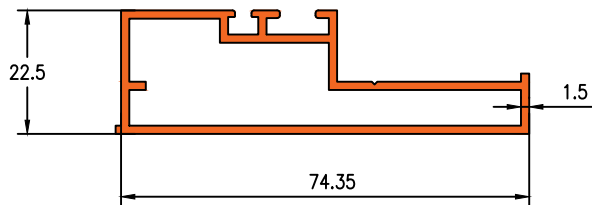

TOGGLE : 7077

Die No. 16162

0.637Kg/m

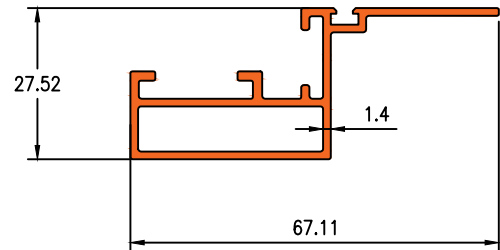

Die No. 16158

0.334Kg/m

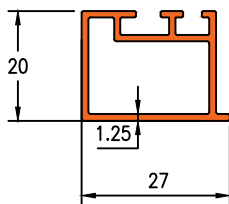

TOGGLE : 16159

Die No. 27066

0.567Kg/m

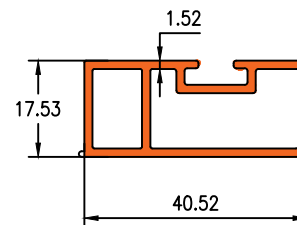

TOGGLE : 1396

Die No. 19748

0.667 Kg/m

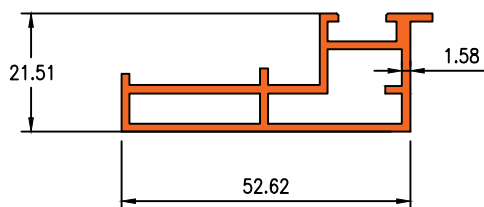

Die No. 20003

0.504Kg/m

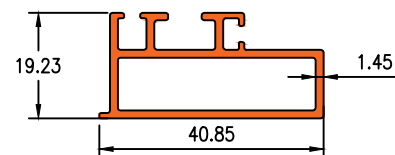

TOGGLE : 7077

Die No. 20009

0.717Kg/m

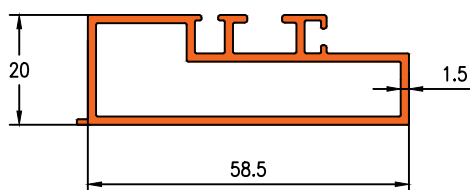

TOGGLE : 7077

Die No. 20012

0.911Kg/m

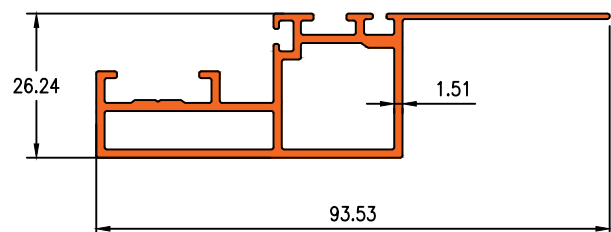

TOGGLE : 19751



Die No. 19354

0.305 Kg/m

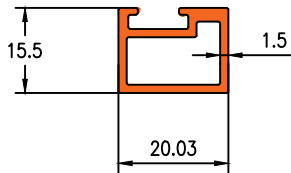

Die No. 21054

0.361 Kg/m

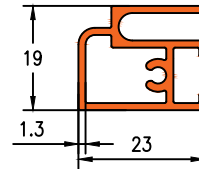

Die No. 21172

0.725 Kg/m

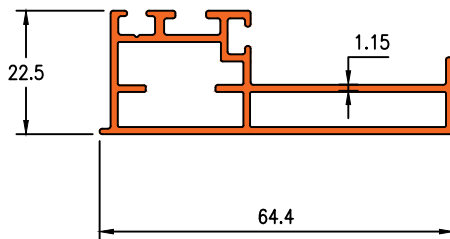

Die No. 19752

0.656 Kg/m

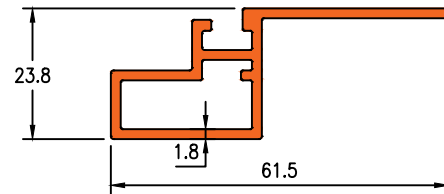

TOGGLE : 19751



Die No. 19356

0.230Kg/m

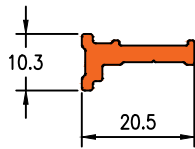

Die No. 7098

0.260Kg/m

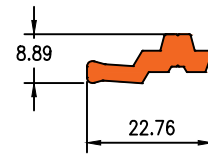

Die No. 1396

0.253Kg/m

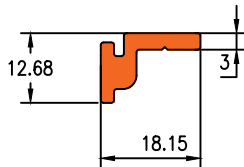

Die No. 1397

0.231Kg/m

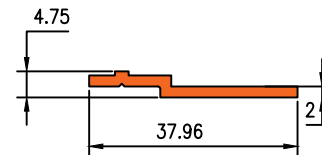

Die No. 16159

0.145Kg/m

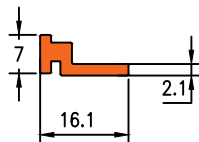

Die No. 7077

0.293Kg/m

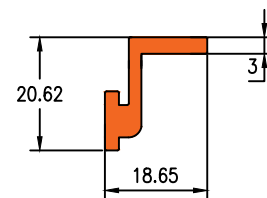

Die No. 1232

0.205Kg/m

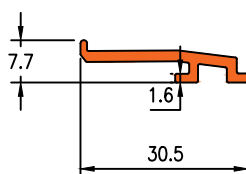

Die No. 19751

0.305Kg/m

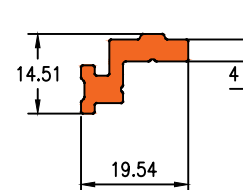



Darshan Extrusions Pvt. Ltd.

Die No. 19326

2.036Kg/m

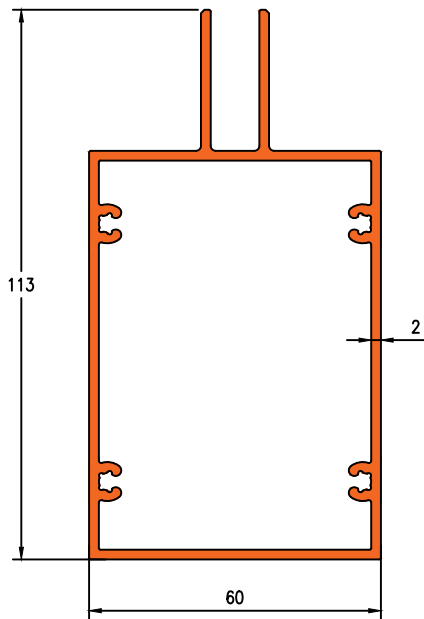

Die No. 19327

0.249Kg/m

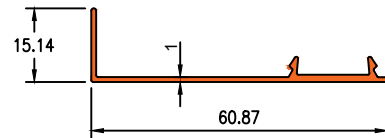

Die No. 19328

1.779Kg/m

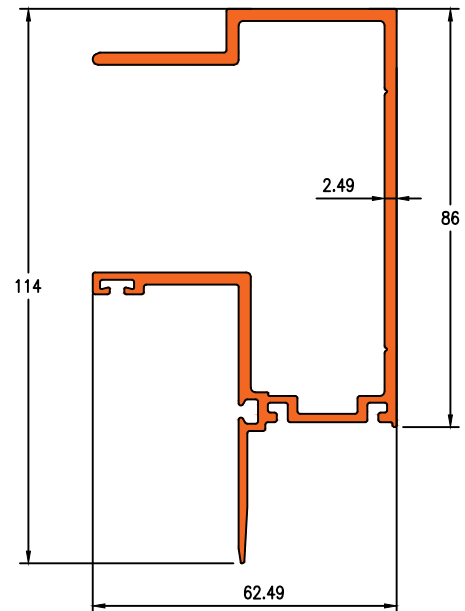

Die No. 19329

1.556Kg/m

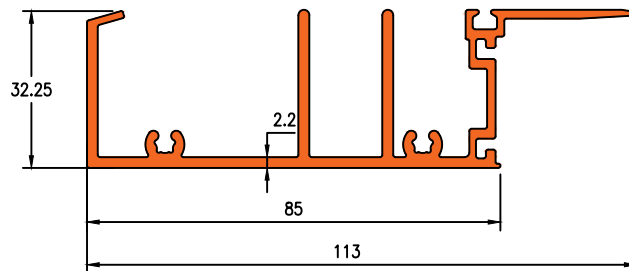

85 MM UNITIZED GLAZING



Die No. 19330

2.382Kg/m

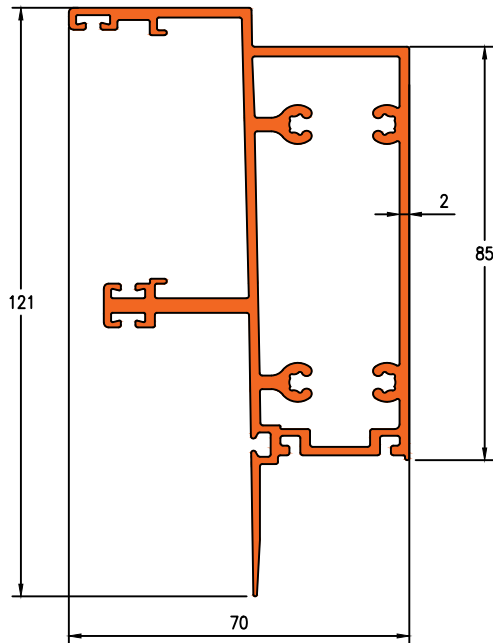

Die No. 19331

1.348Kg/m

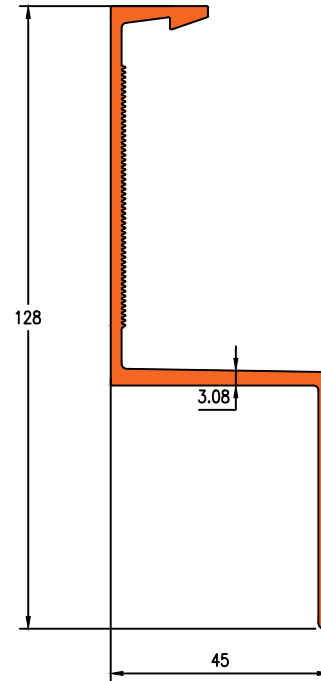



Darshan Extrusions Pvt. Ltd.

Die No. 1404

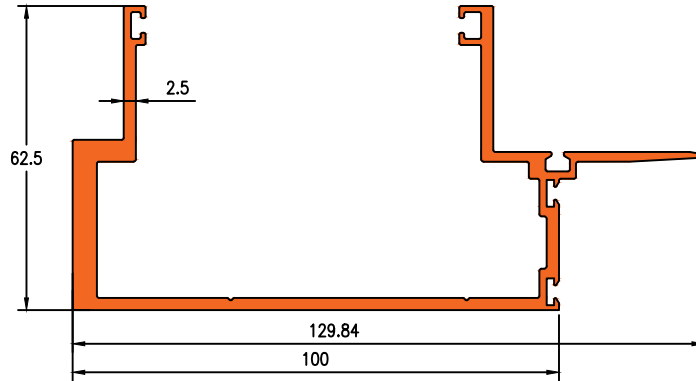

2.072 Kg/m

Die No. 1406

1.070 Kg/m

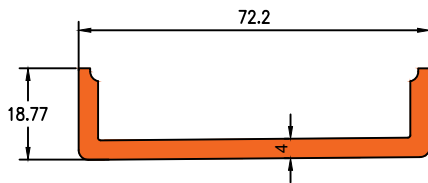

Die No. 1408

2.906 Kg/m

100 MM UNITIZED GLAZING



Darshan Extrusions Pvt. Ltd.

Die No. 1444

0.649Kg/m

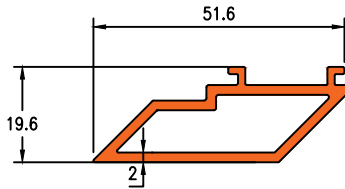

Die No. 1413

1.735Kg/m

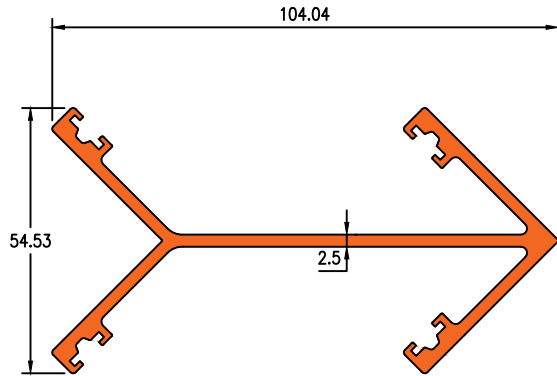

Die No. 1402

0.198Kg/m

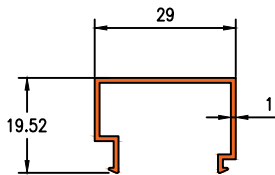

Die No. 1445

0.190Kg/m

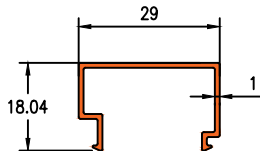



Darshan Extrusions Pvt. Ltd.

Die No.27001

1.739Kg/m

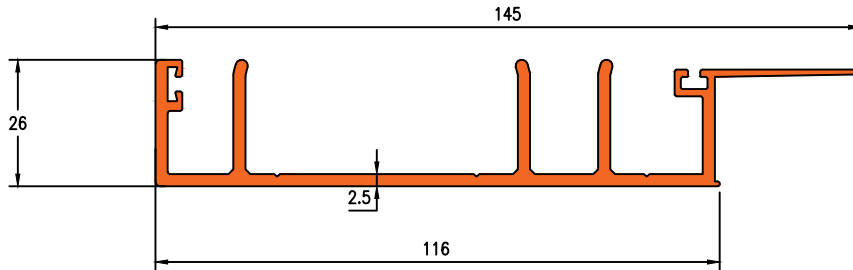

Die No.27004

1.442Kg/m

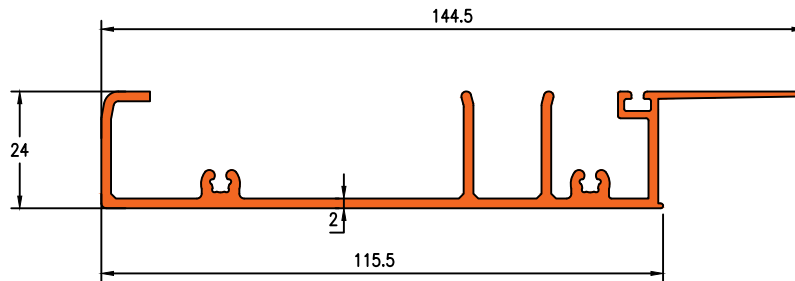

Die No.27005

2.504Kg/m

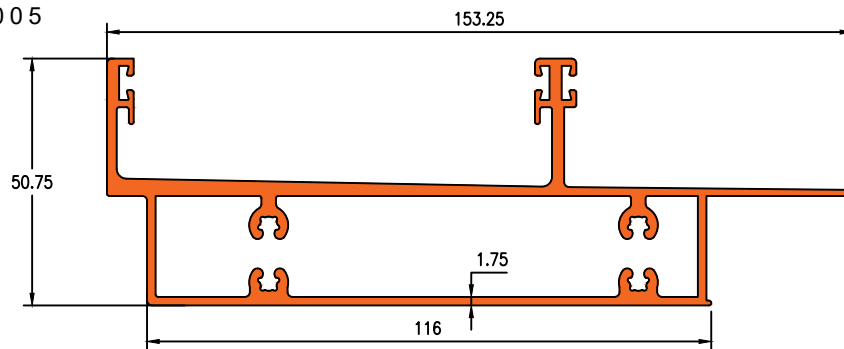

Die No.27006

0.976Kg/m

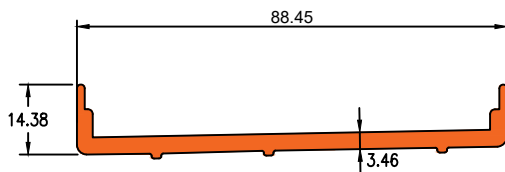

116 MM UNITIZED SYSTEM



Darshan Extrusions Pvt. Ltd.

Die No.27000

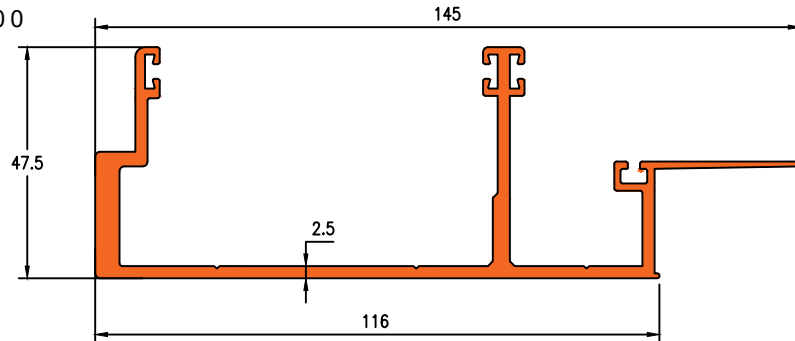

2.013Kg/m

Die No.27002

2.143Kg/m

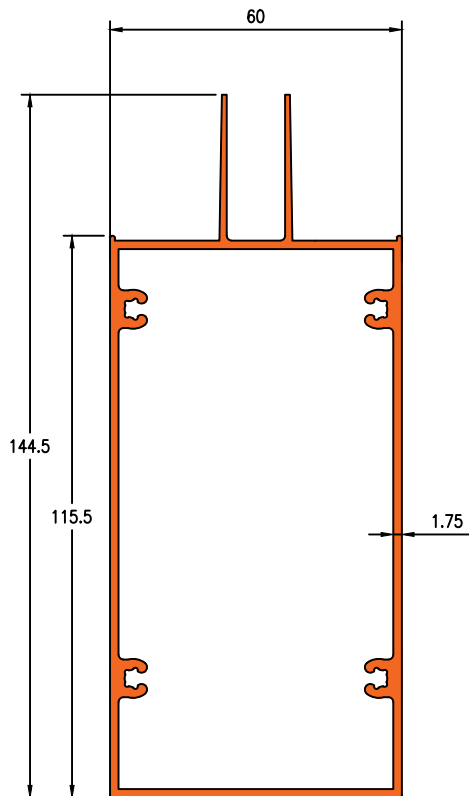

Die No.27003

1.628Kg/m

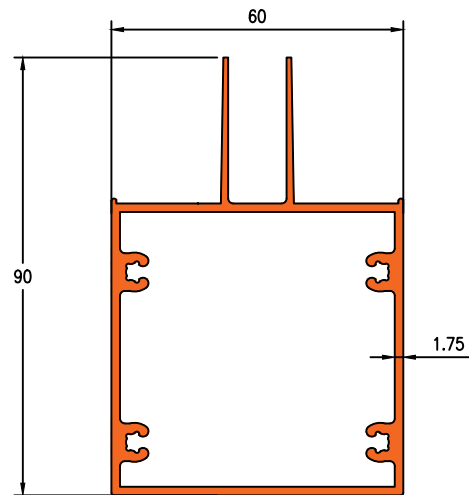

116 MM UNFINISHED SYSTEM



Die No. 27050

2.478Kg/m

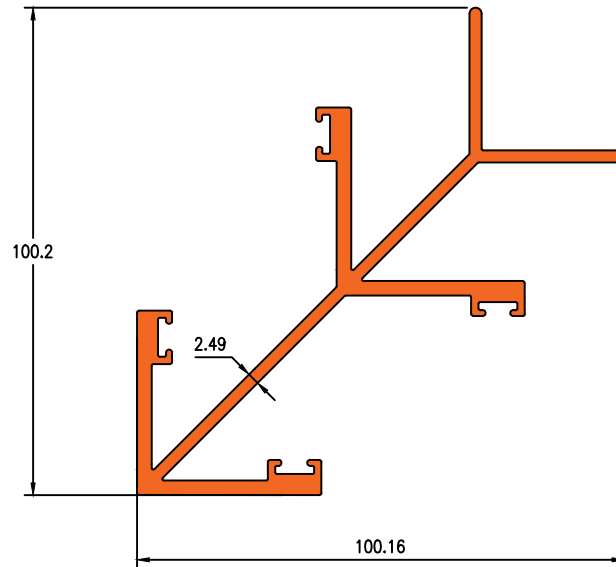

Die No. 27051

2.244Kg/m

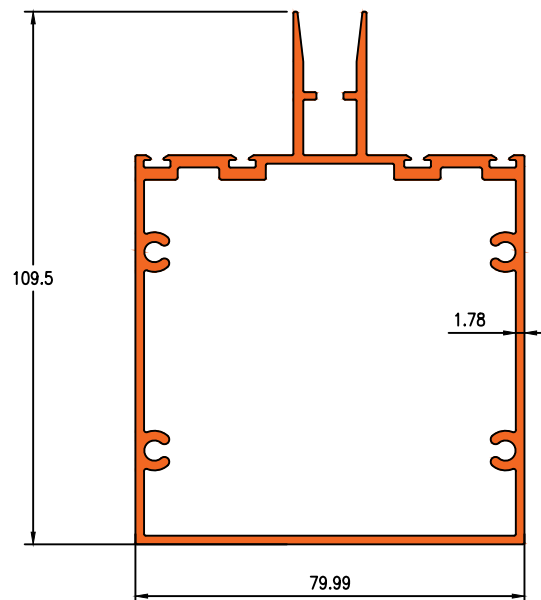



Darshan Extrusions Pvt. Ltd.

Die No. 27052

1.418Kg/m

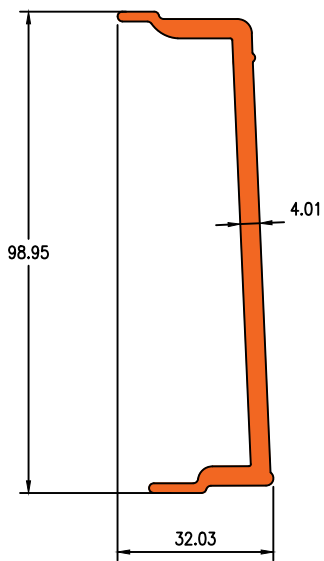

Die No. 27053

1.829Kg/m

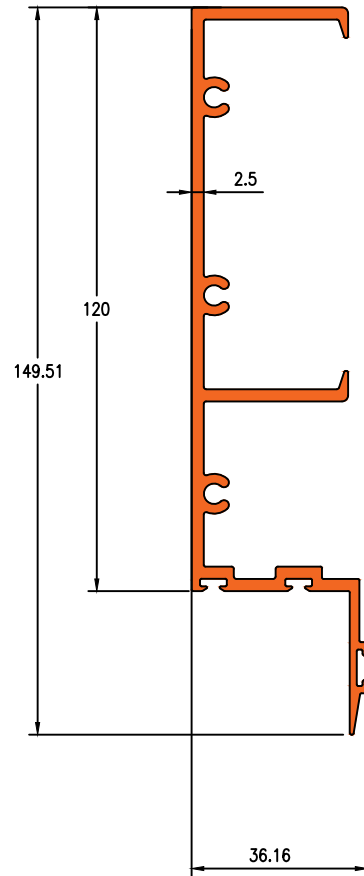

Die No. 27054

1.946Kg/m

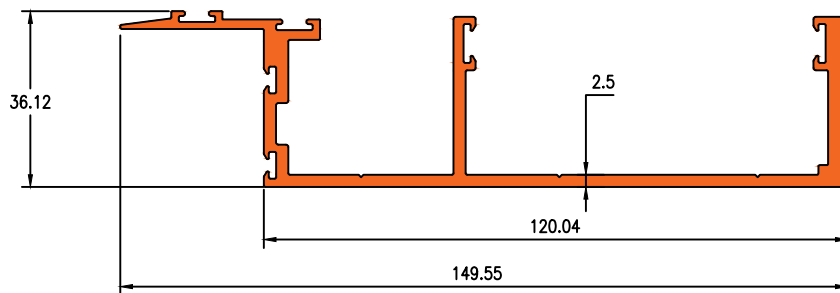

120 MM UNITIZED GLAZING



Darshan Extrusions Pvt. Ltd.

Die No. 27055

2.467Kg/m

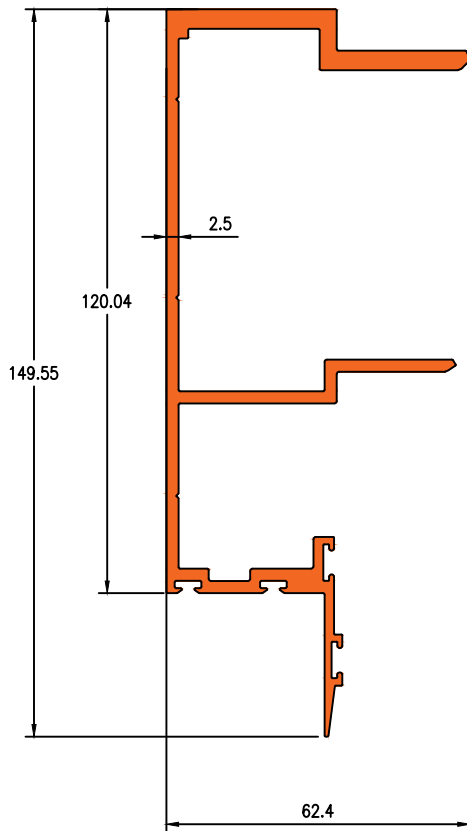

Die No. 27057

0.295Kg/m

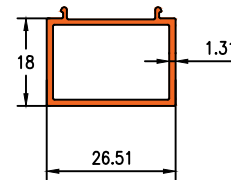

Die No. 27058

0.296Kg/m

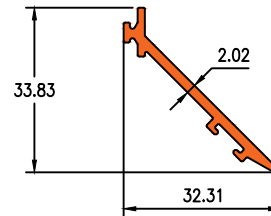

Die No. 27059

0.402Kg/m

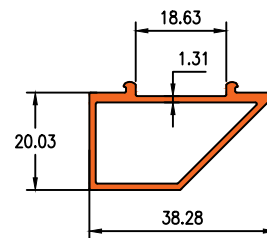

Die No. 27056

0.309Kg/m

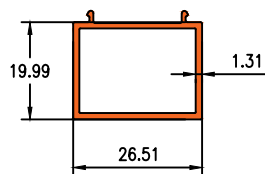

Die No. 27060

0.392Kg/m

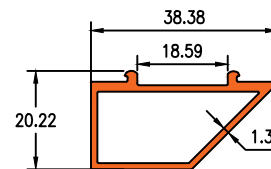

120 MM UNITIZED GLAZING



Darshan Extrusions Pvt. Ltd.

Die No. 27061

3.126Kg/m

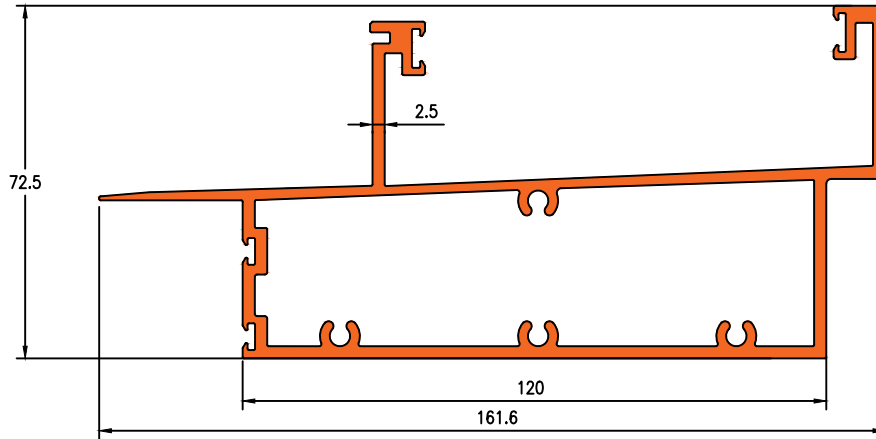

Die No. 19909

3.680Kg/m

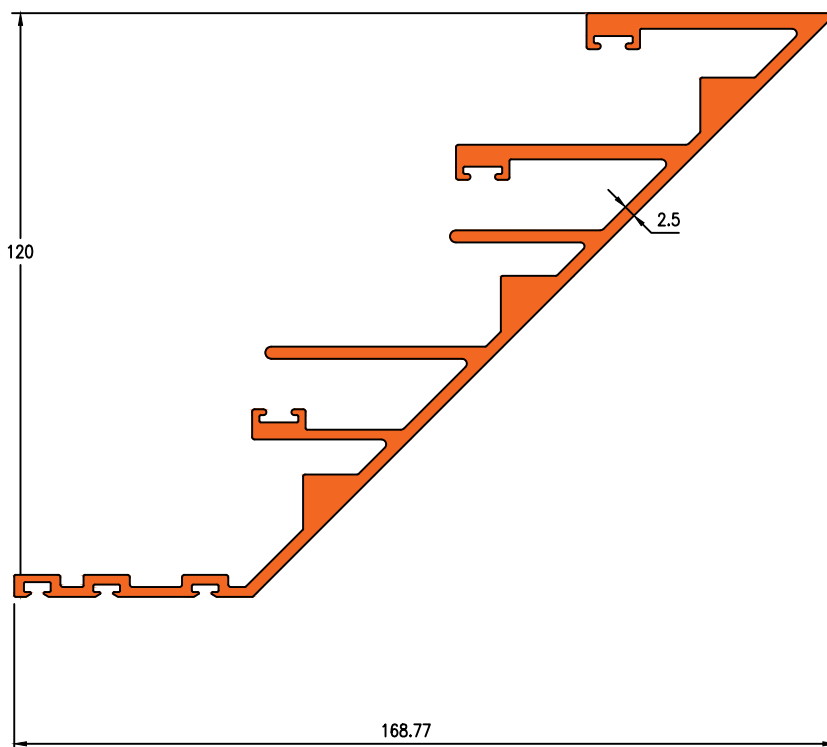

120 MM UNITIZED GLAZING



Die No. 16564

2.870Kg/m

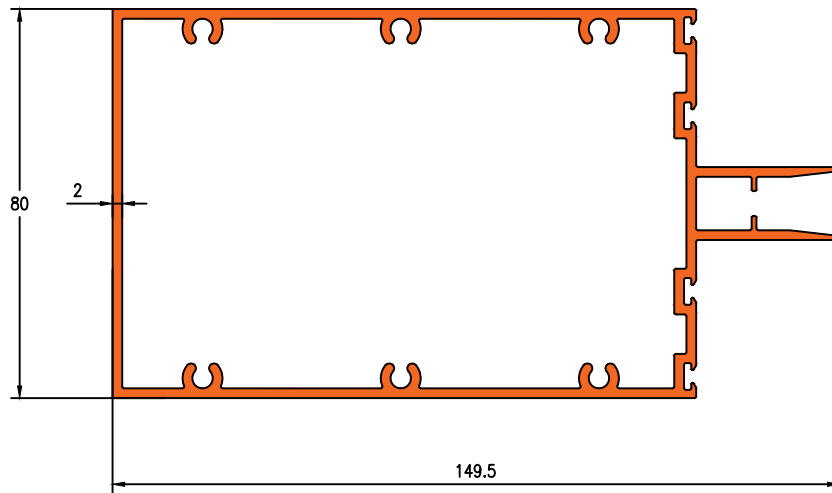





Darshan Extrusions Pvt. Ltd.

Die No.27032

2.717Kg/m

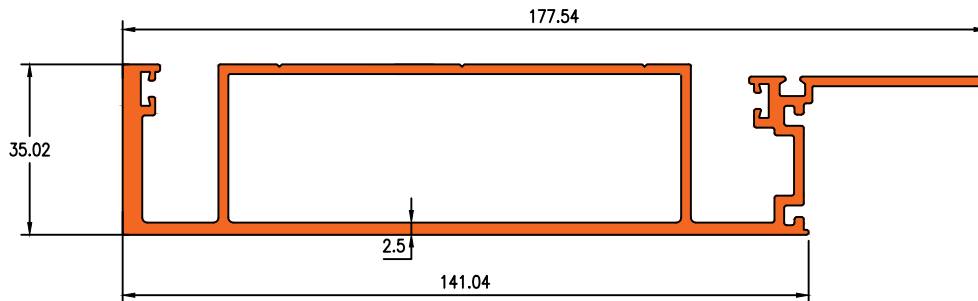

Die No.27034

2.702Kg/m

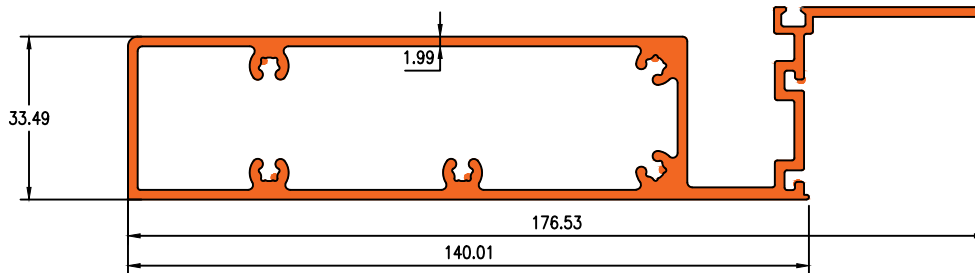

Die No.27033

1.935Kg/m

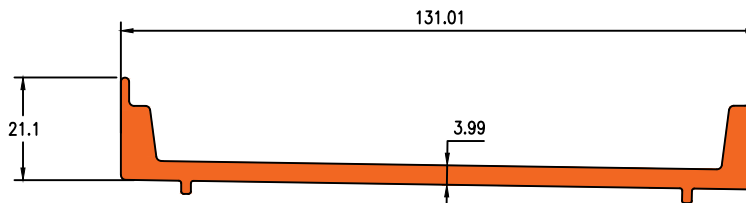

Die No.27035

0.450Kg/m

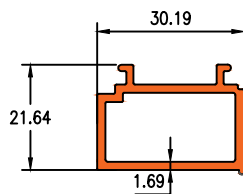

140 MM UNITIZED SYSTEM



Die No.27031

2.533Kg/m

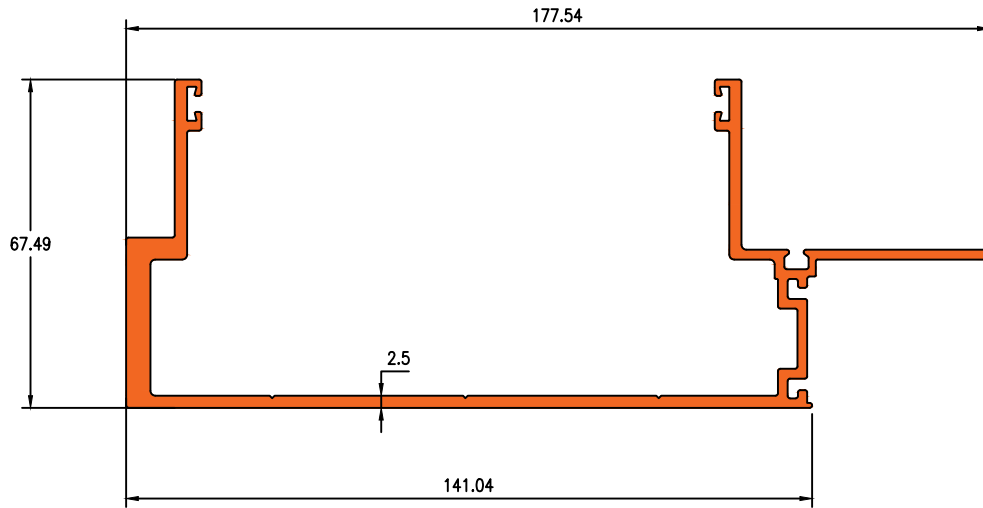



Die No.23096

2.692Kg/m

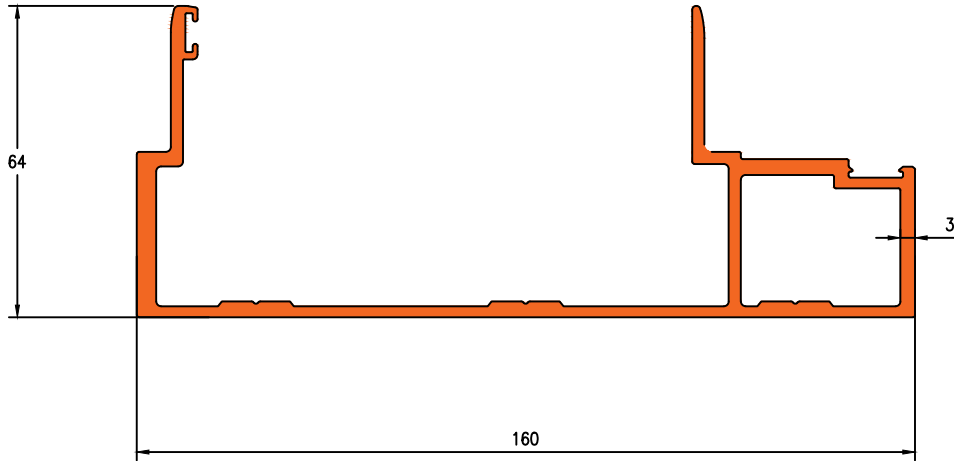

Die No.23097

2.415Kg/m

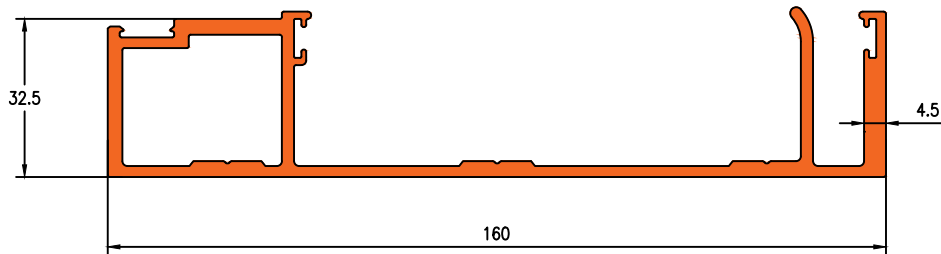

Die No.23099

2.722Kg/m

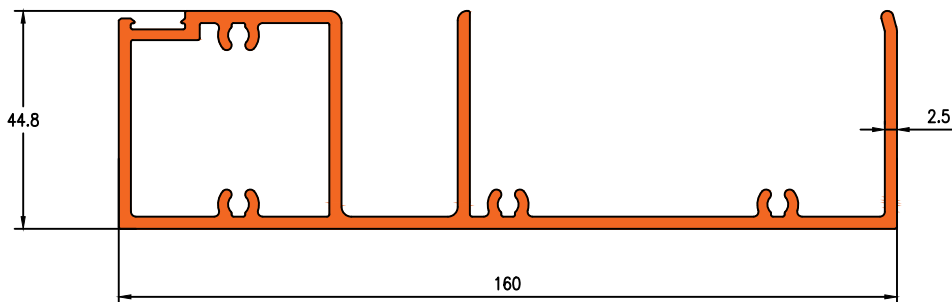



Die No.23100

3.704Kg/m

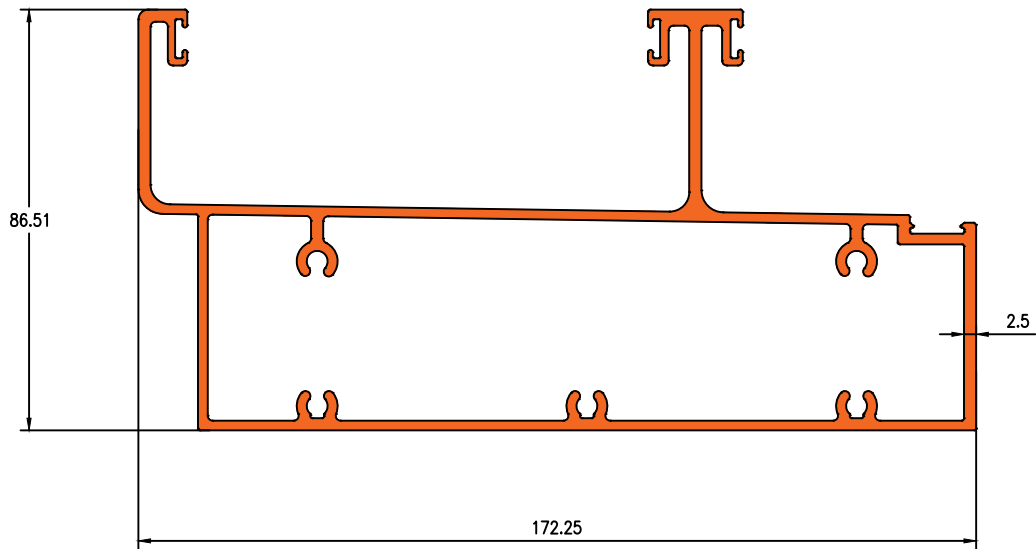

Die No.23098

2.255Kg/m

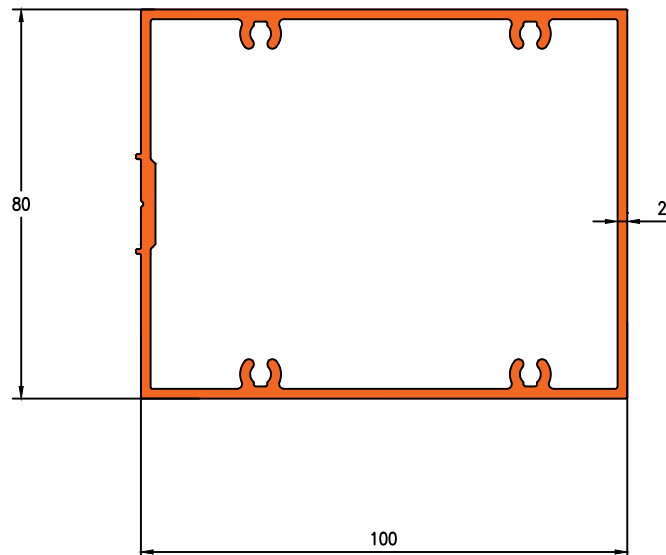



Darshan Extrusions Pvt. Ltd.

Die No. 1701

0.519 Kg/m
0.683 kg/m
0.846 kg/m

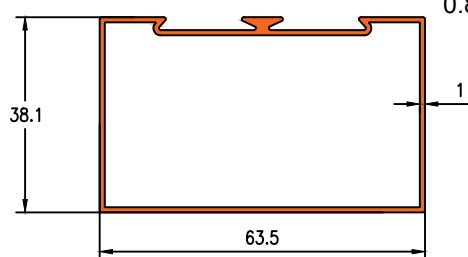

Die No. 1721

0.519 Kg/m
0.683 kg/m
0.846 kg/m

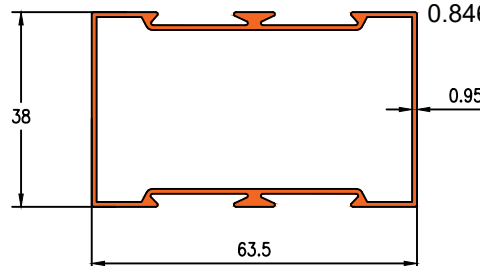

Die No. 1480

0.732 Kg/m

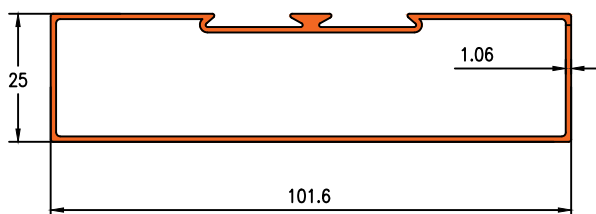

Die No. 1481

0.833 Kg/m

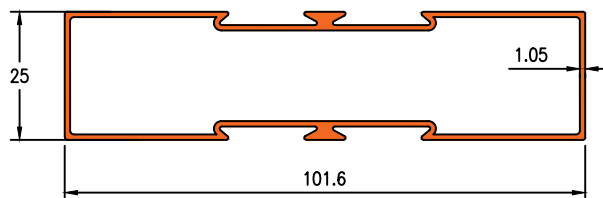

Die No. 21142

0.726 Kg/m

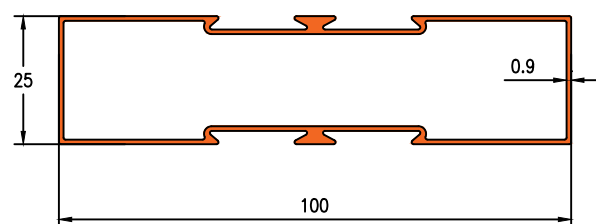

Die No. 1771

1.502 Kg/m
2.377 kg/m

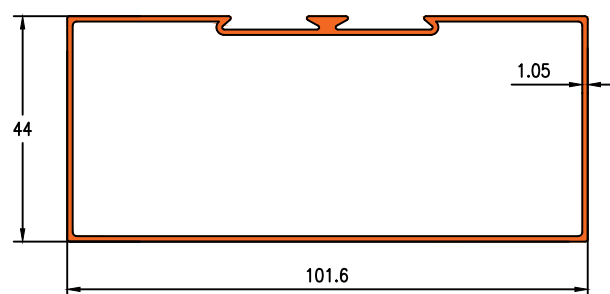

Die No. 1791

1.502 Kg/m
2.431 kg/m

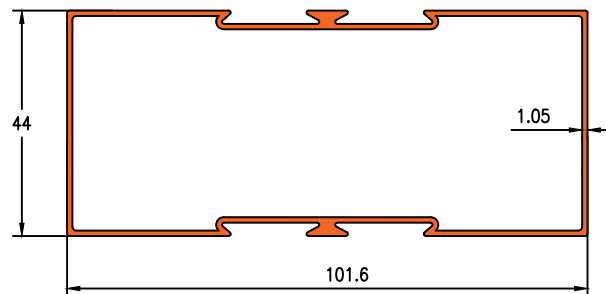



Darshan Extrusions Pvt. Ltd.

Die No. 3503

0.732 Kg/m

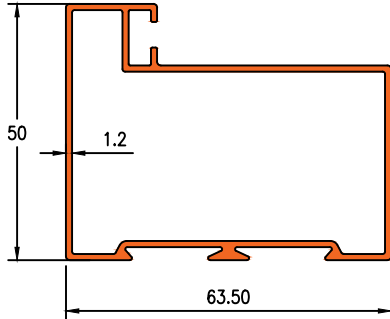

Die No. 1901

0.074 Kg/m

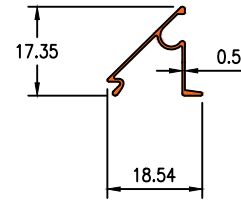

Die No. 1741

0.573 Kg/m
0.846 kg/m

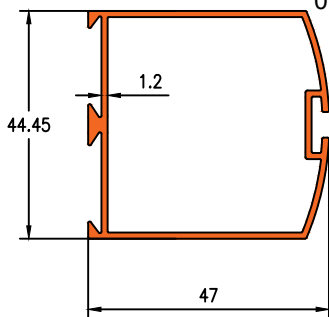

Die No. 2601

0.573 Kg/m

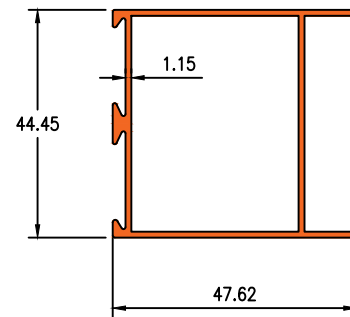

Die No. 1761

0.628 Kg/m

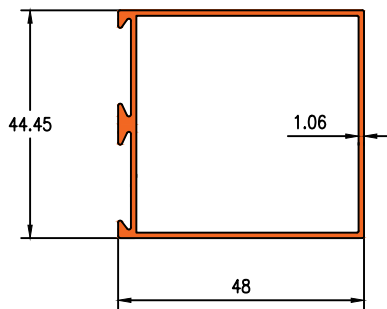

Die No. 2751

0.819 Kg/m

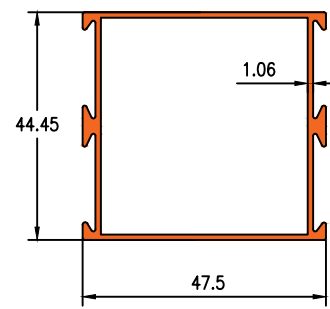

Die No. 1773

2.076 Kg/m

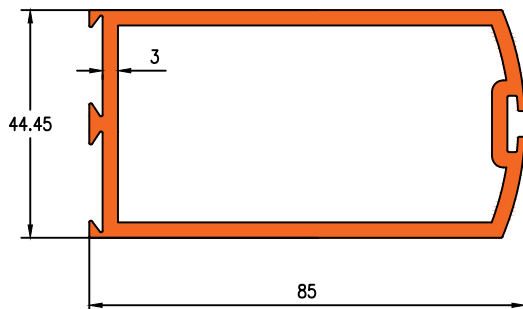

Die No. 1770

1.120 Kg/m

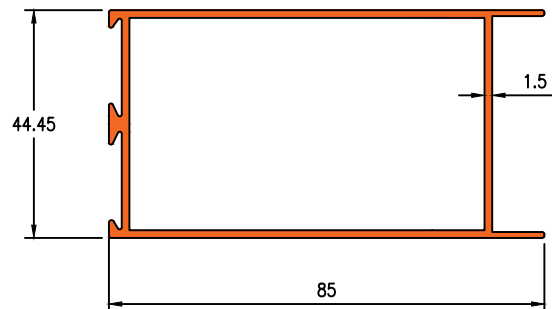



Darshan Extrusions Pvt. Ltd.

Die No. 1775

1.010 Kg/m

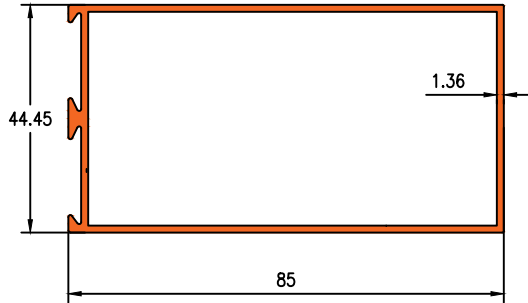

Die No. 1778

1.065 Kg/m

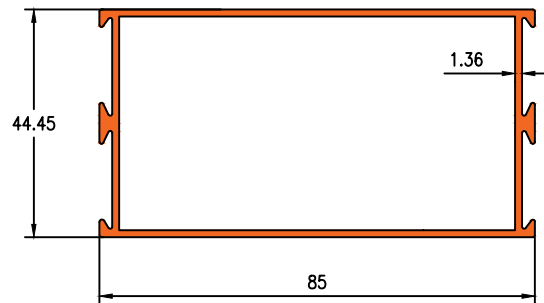

Die No. 1181

1.393 Kg/m

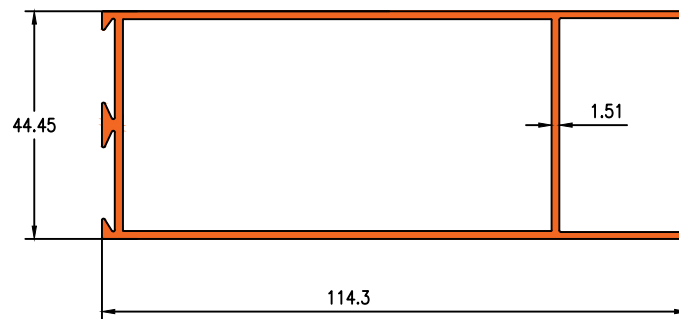



Darshan Extrusions Pvt. Ltd.

Die No. 16082

0.503Kg/m

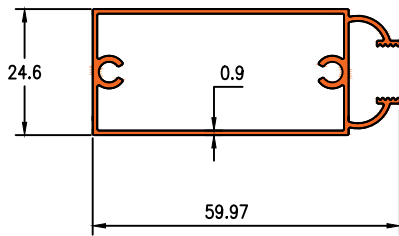

Die No.19361

0.475Kg/m

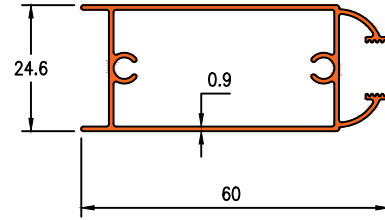

Die No. 16083

0.530Kg/m

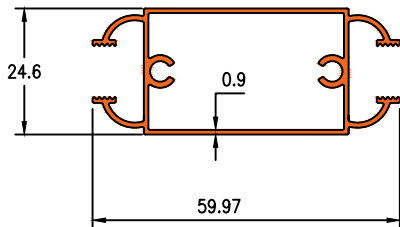

Die No. 16084

0.579Kg/m

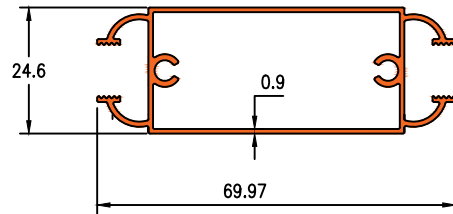

Die No. 16085

0.600Kg/m

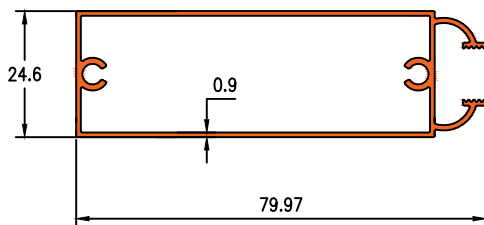



Darshan Extrusions Pvt. Ltd.

Die No. 16087

0.430 Kg/m

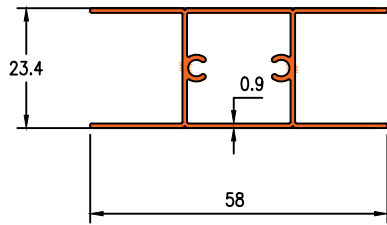

Die No. 16088

0.335 Kg/m

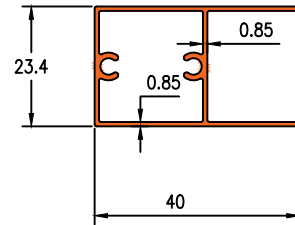

Die No. 21012

0.403 Kg/m

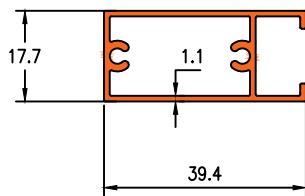

Die No. 5228

1.606 Kg/m

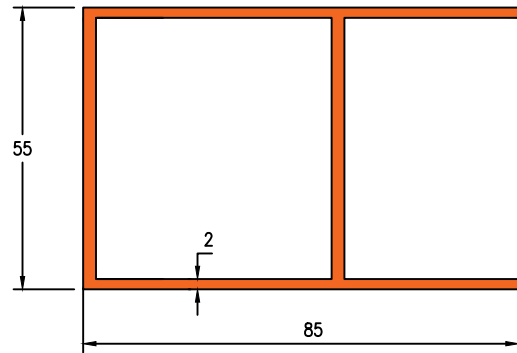

Die No. 21013

0.990 Kg/m

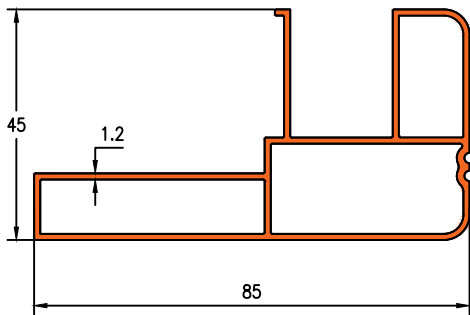

Die No. 7048

0.635 Kg/m

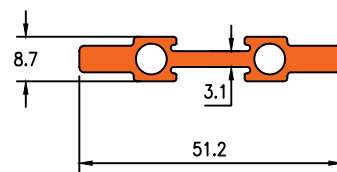

Die No. 7049

0.222 Kg/m

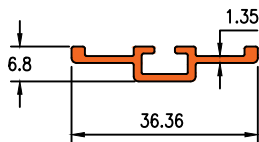

Die No. 7050

0.306 Kg/m

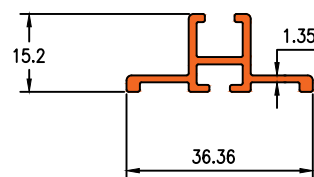



Darshan Extrusions Pvt. Ltd.

Die No. 7017

0.367 Kg/m

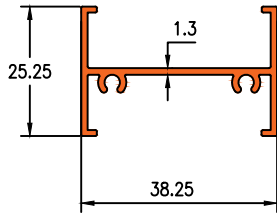

Die No. 7018

0.367 Kg/m

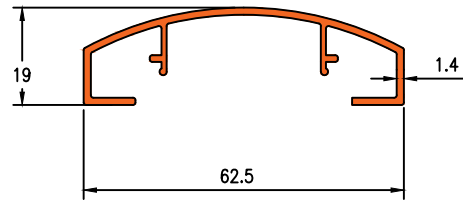

Die No. 7019

0.595 Kg/m

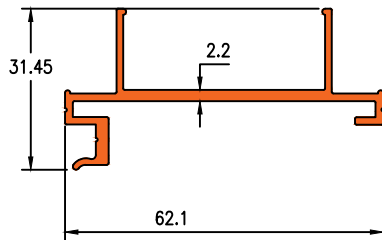

Die No. 7020

0.506 Kg/m

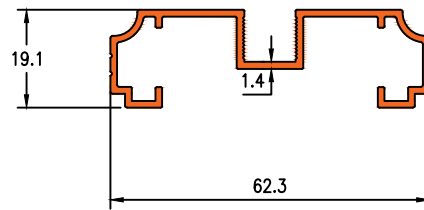

Die No. 7021

0.594 Kg/m

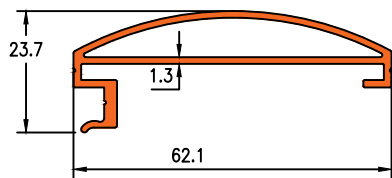

Die No. 7022

1.453 Kg/m

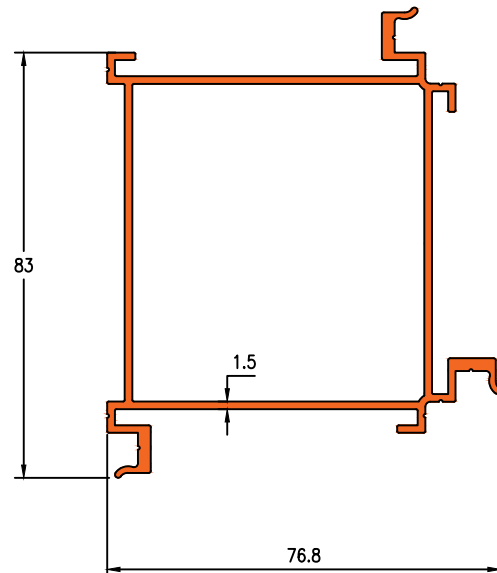

Die No. 7023

1.116 Kg/m

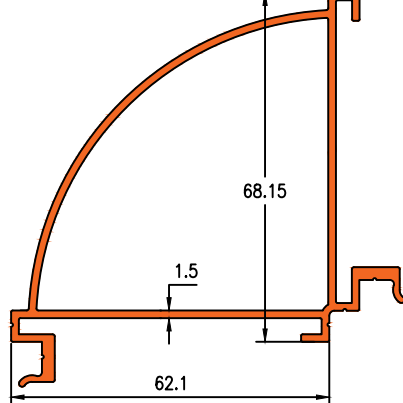



Darshan Extrusions Pvt. Ltd.

Die No. 19613

1.595 Kg/m

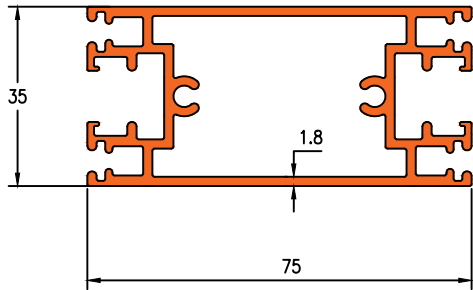

Die No. 19954

0.600 Kg/m

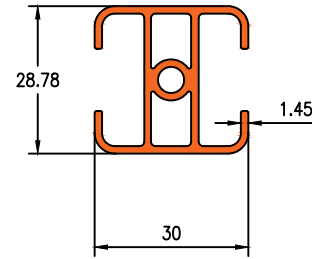

Die No. 19628

1.111 Kg/m

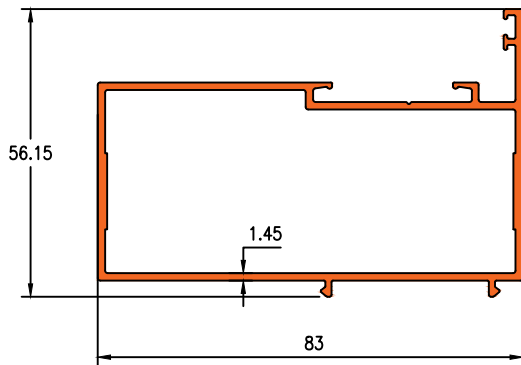

CLIP: 4006 & 4007

Die No. 19629

0.985 Kg/m

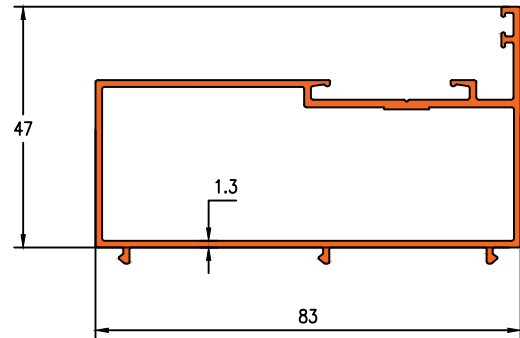

CLIP: 4006 & 4007

Die No. 19631

1.366 Kg/m

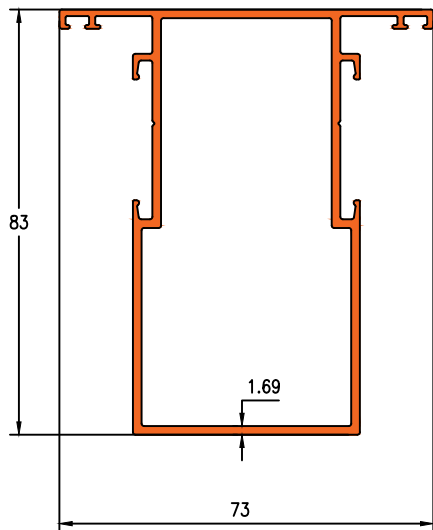

CLIP: 4006 & 4007

Die No. 19630

1.020 Kg/m

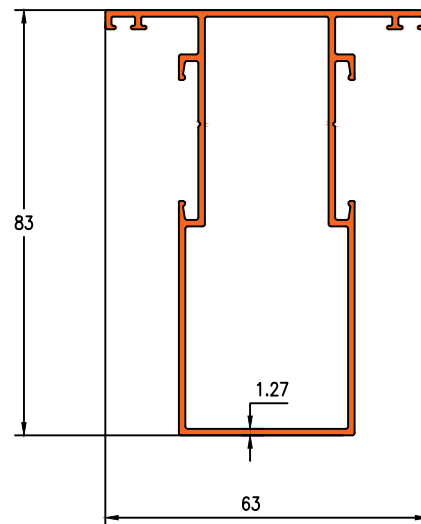

CLIP: 4006 & 4007



Darshan Extrusions Pvt. Ltd.

Die No. 1268

0.412 Kg/m

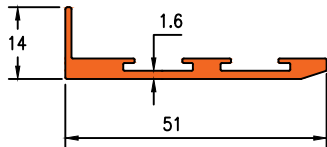

Die No. 19739

0.347 Kg/m

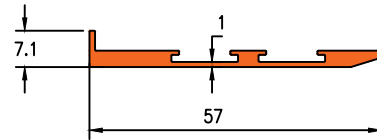

Die No. 19740

0.292 Kg/m

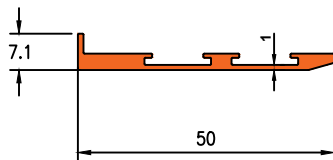

Die No. 23019

0.534 Kg/m

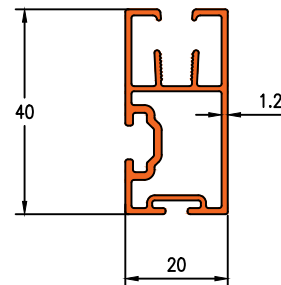

Die No. 16086

0.710 Kg/m

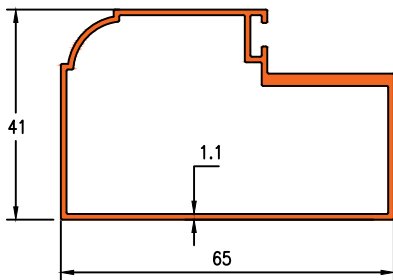

Die No. 16185

0.623 Kg/m

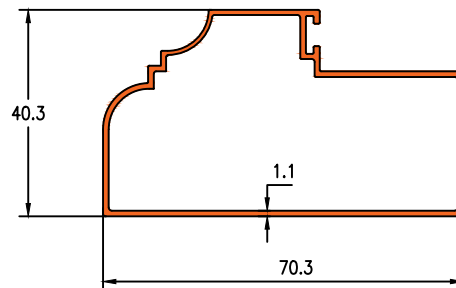

Die No. 10139

0.691 Kg/m

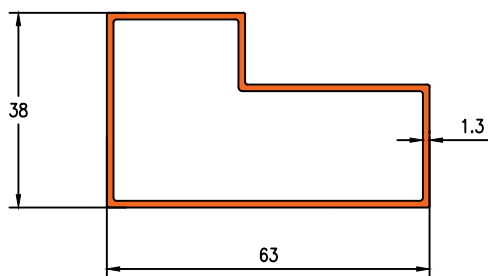

Die No. 10140

0.769 Kg/m

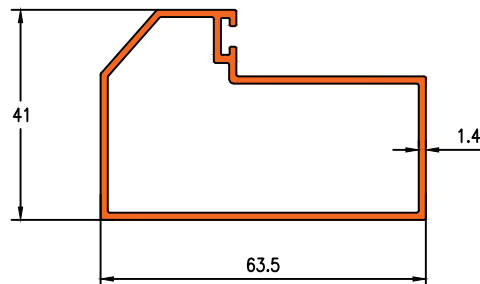



Die No. 19815

2.208 Kg/m

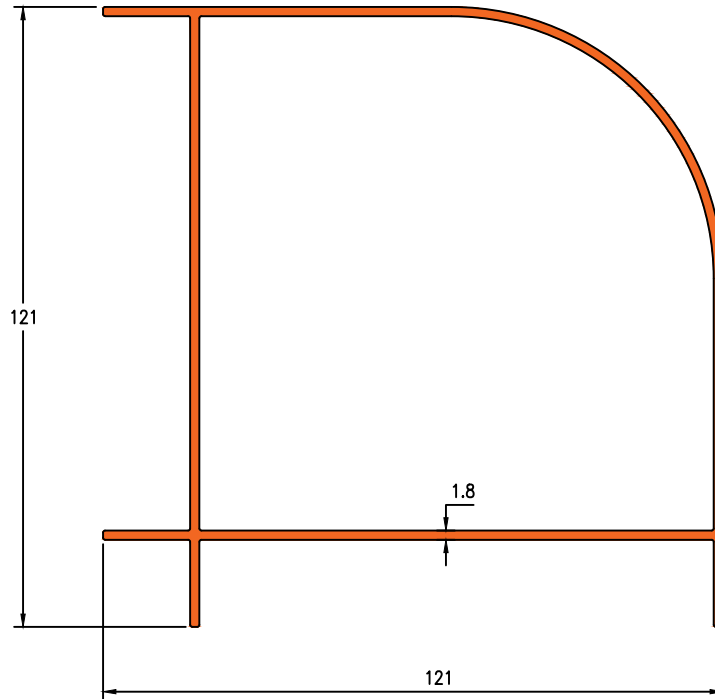

Die No. 19814

1.320 Kg/m

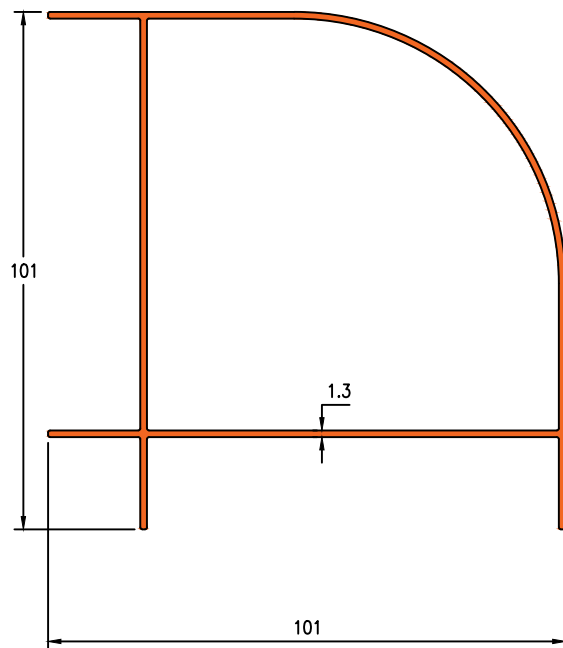

Die No. 19813

0.899 Kg/m

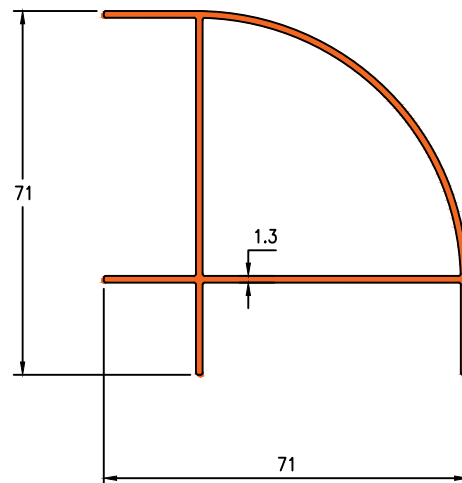



Die No. 16045

0.498 Kg/m

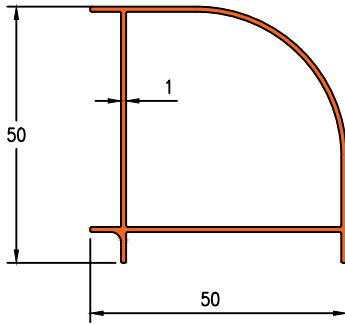

Die No. 16252

4.461 Kg/m

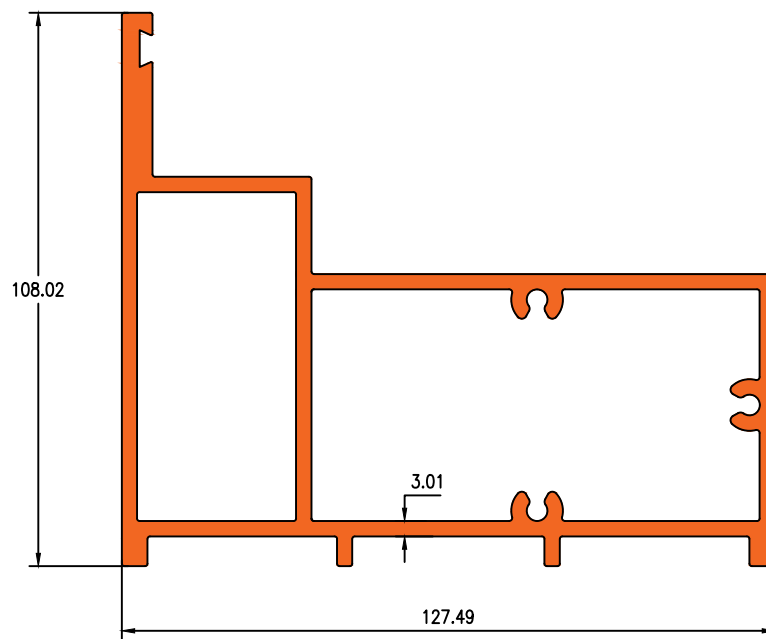

Die No. 16068

1.486 Kg/m

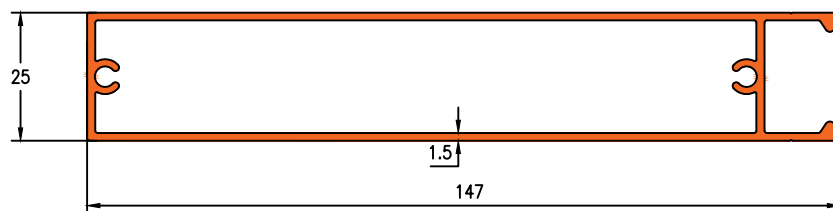



Darshan Extrusions Pvt. Ltd.

Die No.22031

0.491KG/M

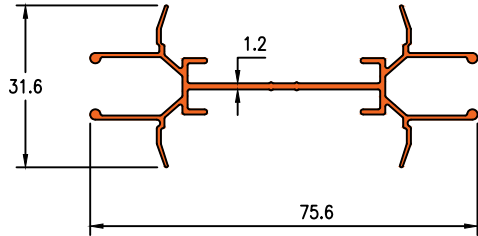

Die No. 22032

0.282KG/M

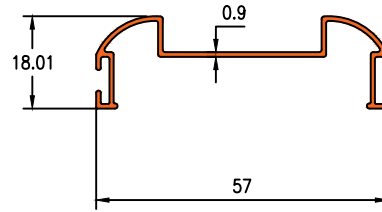

Die No. 22033

0.223 KG/M

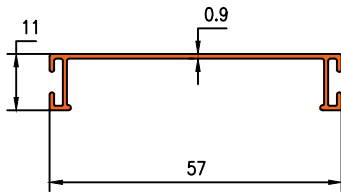

Die No. 22034

0.150 KG/M

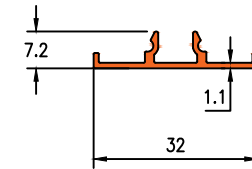

Die No. 22035

0.153 KG/M

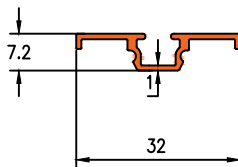

Die No. 22036

1.182 KG/M

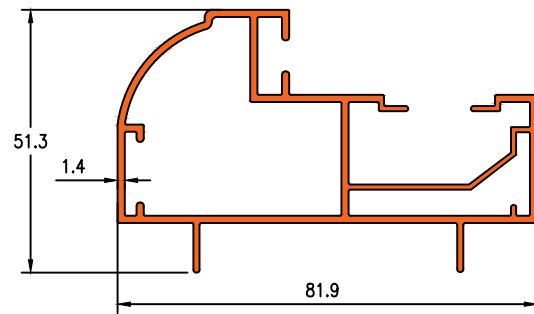



Die No.22037

1.663 KG/M

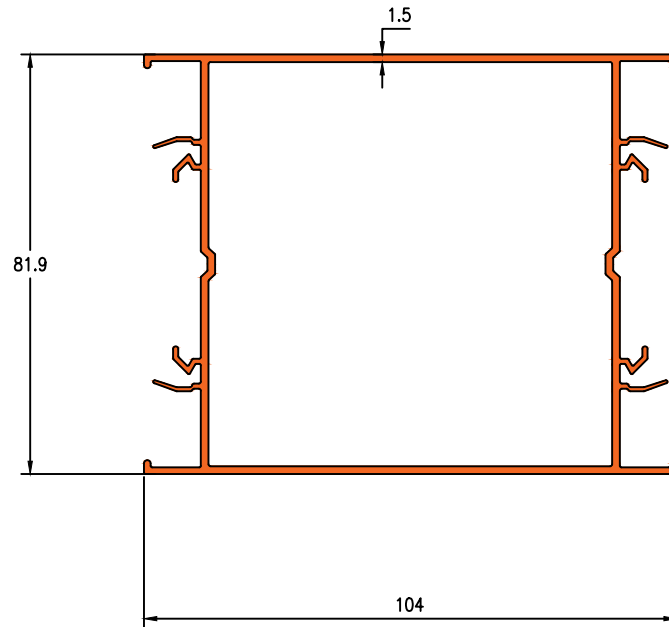

Die No. 22038

1.568 KG/M

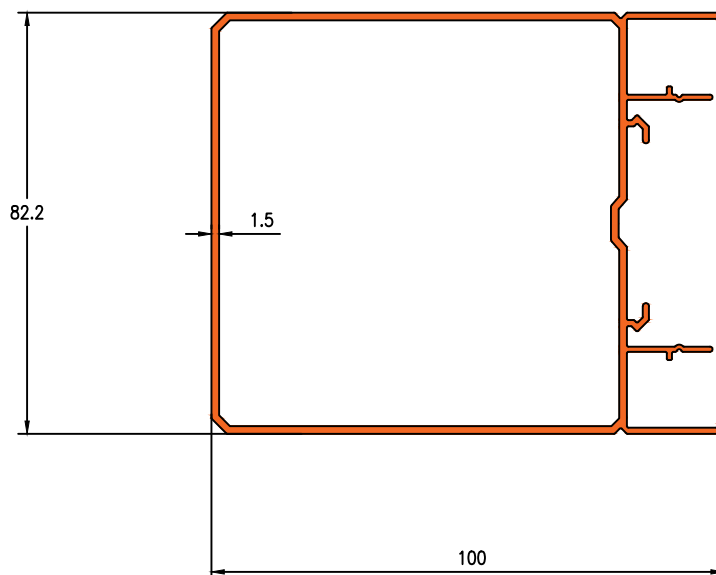



Darshan Extrusions Pvt. Ltd.

Die No.22039

1.301 KG/M

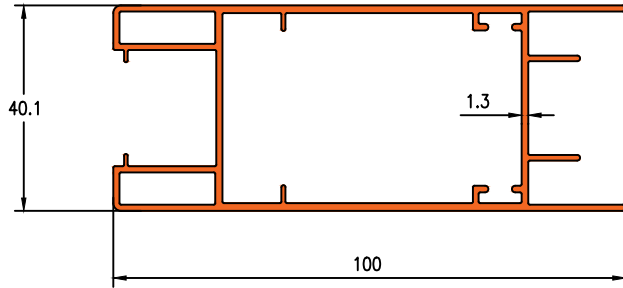

Die No. 22040

0.970KG/M

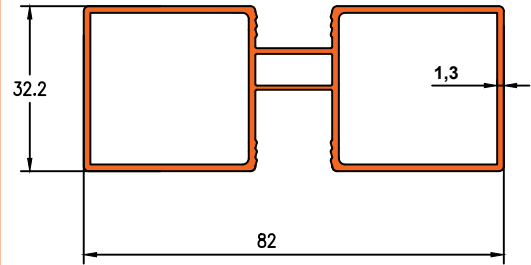

Die No. 22041

0.859 KG/M

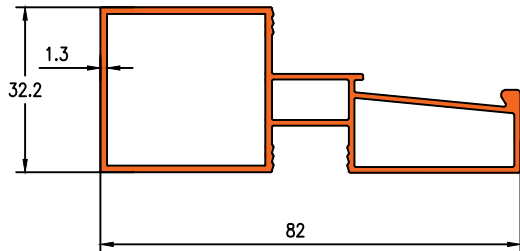

Die No. 22042

0.227KG/M

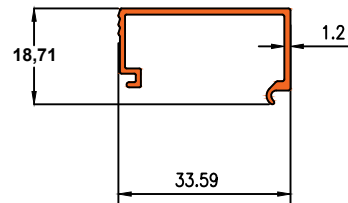

Die No. 22043

1.264 KG/M

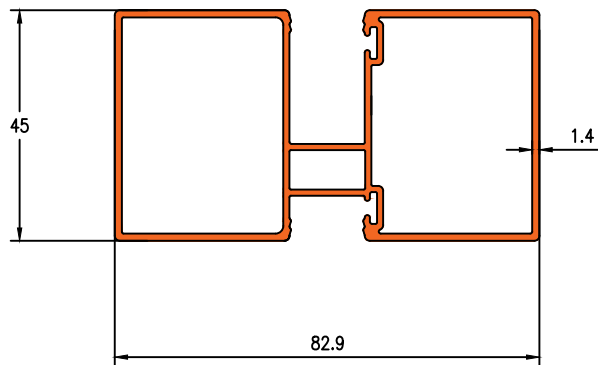



Darshan Extrusions Pvt. Ltd.

Die No.7045

1.543Kg/m

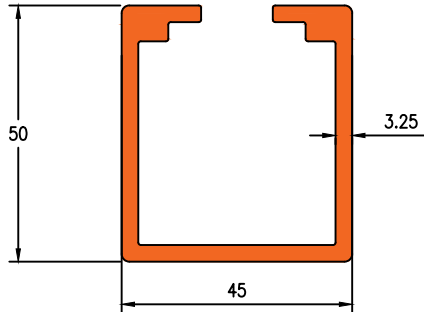

Die No.19830

0.599Kg/m

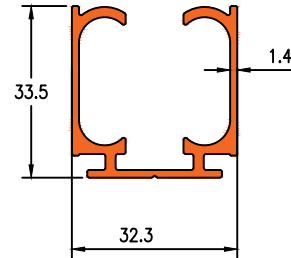

Die No.7044

1.174Kg/m

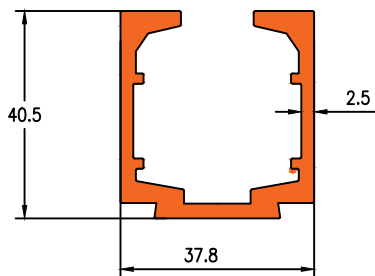

Die No.7062

0.961Kg/m

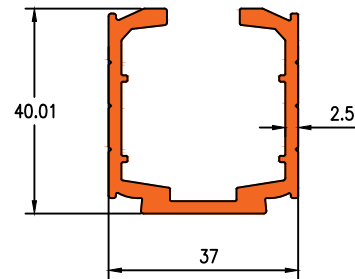

Die No.7042

1.778Kg/m

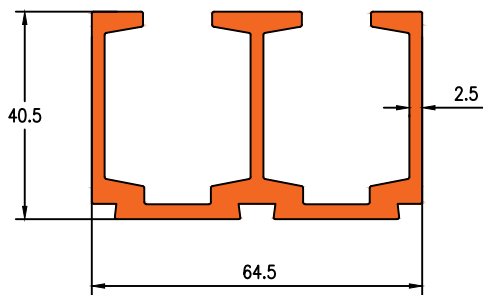

Die No.7043

1.468Kg/m

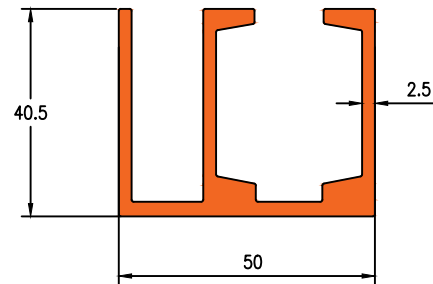

Die No.7063

1.357Kg/m

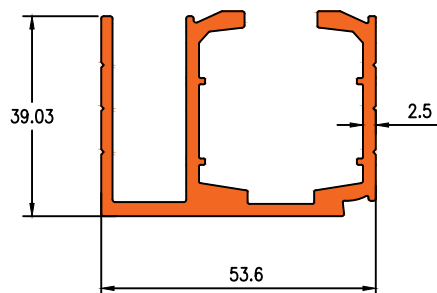

Die No.7064

1.736Kg/m

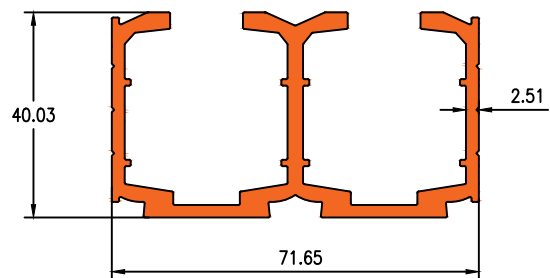



Darshan Extrusions Pvt. Ltd.

Die No.19838

0.767Kg/m

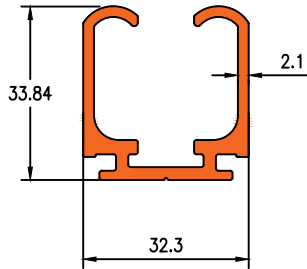

Die No.19948

1.362Kg/m

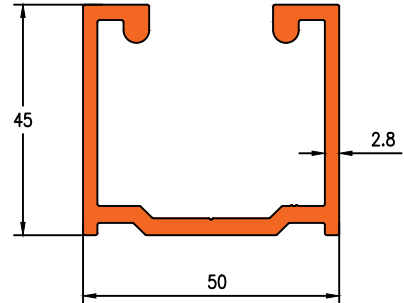

Die No.1296

0.552Kg/m

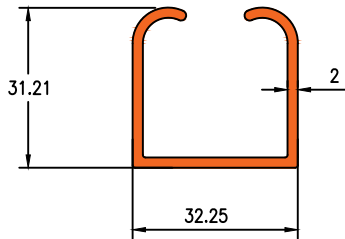

Die No.19837

1.818Kg/m

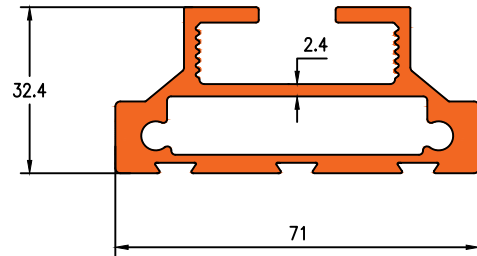

Die No.19658

0.621Kg/m

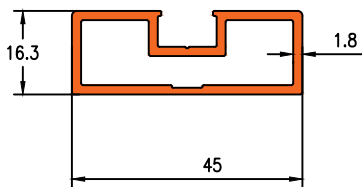

Die No.19657

0.790Kg/m

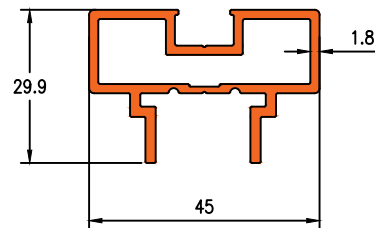

Die No.20053

0.631Kg/m

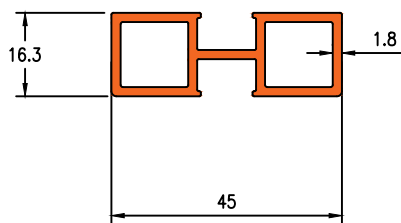

Die No.23159

0.751 Kg/m

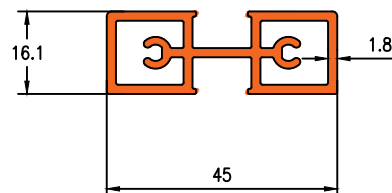



Darshan Extrusions Pvt. Ltd.

Die No.23130

0.564 Kg/m

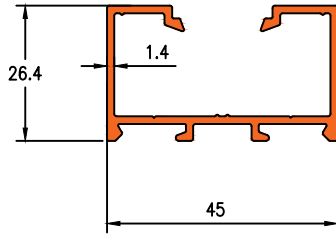

CLIP - 23133

Die No.23131

0.455 Kg/m

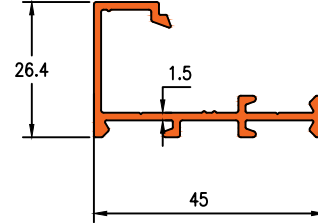

CLIP - 23132

Die No.23132

0.169 Kg/m

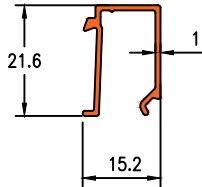

Die No.23133

0.203 Kg/m

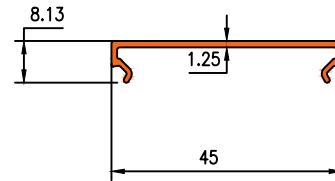

Die No.23115

0.568 KG/M

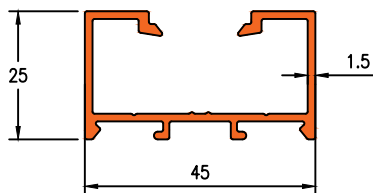

CLIP - 23101

Die No.23116

0.457 KG/M

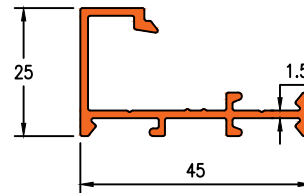

CLIP - 23117

Die No.23117

0.164 KG/M

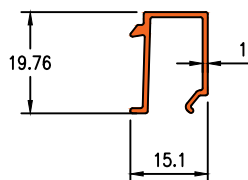

Die No.23101

0.265 KG/M

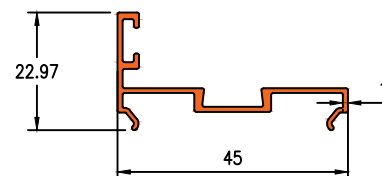



Darshan Extrusions Pvt. Ltd.

Die No.23102

0.169 Kg/m

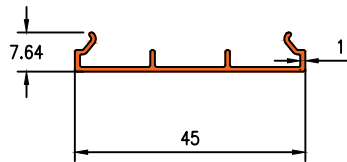

Die No.22052

0.457 KG/M

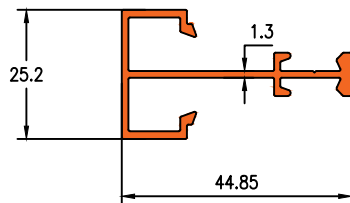

CLIP - 22053

Die No.22053

0.122 KG/M

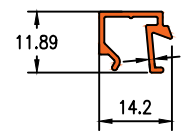



Darshan Extrusions Pvt. Ltd.

Die No.23134

1.050 KG/M

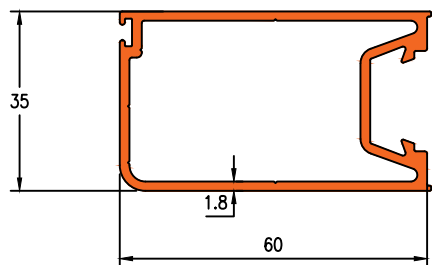

Die No.22051

1.053 KG/M

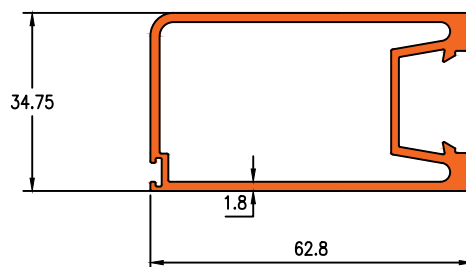

Die No.16590

1.059 KG/M

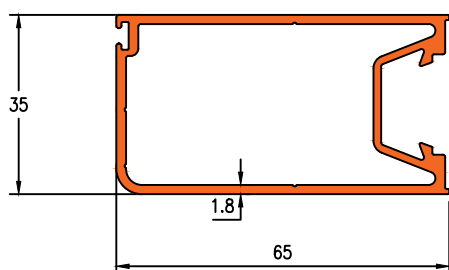

Die No.22050

1.233 KG/M

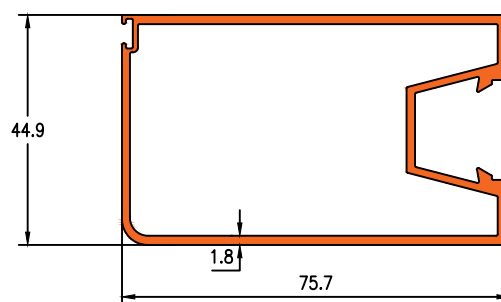

Die No.22083

0.773 KG/M

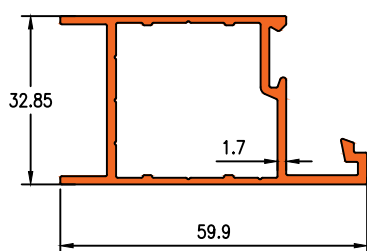

Die No.22084

0.177 KG/M

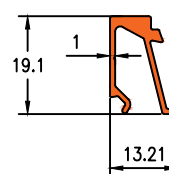

Die No.23149

0.871 KG/M

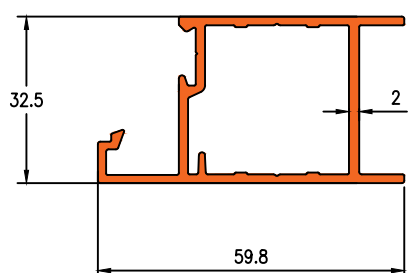

Die No.23150

0.177 KG/M

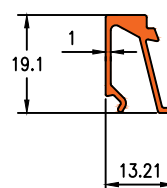



Darshan Extrusions Pvt. Ltd.

Die No.22059

1.073 KG/M

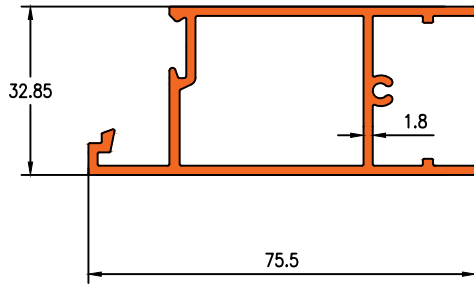

Die No.22060

0.177 KG/M

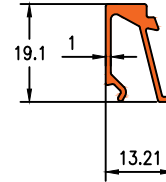

Die No.23135

1.214KG/M

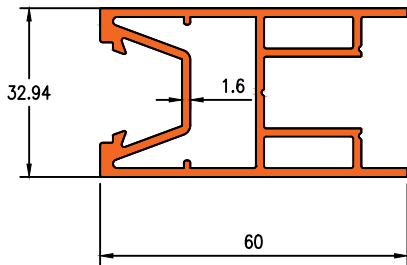

Die No.16510

1.535KG/M

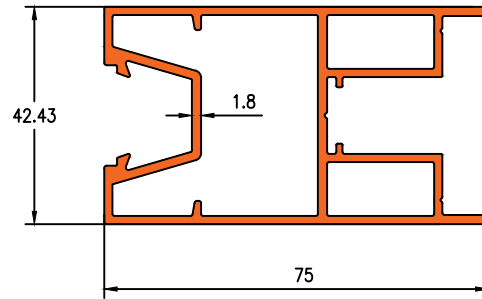

Die No.22045

1.465 KG/M

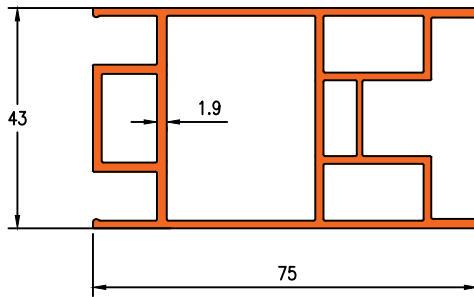

Die No.16494

1.841KG/M

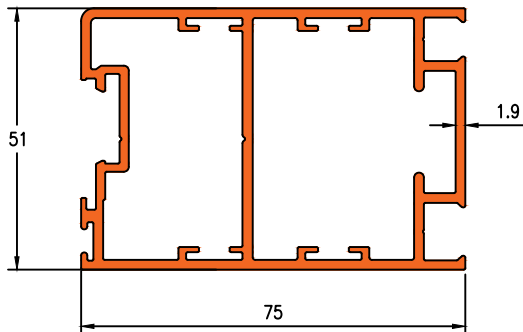

Die No.16495

1.923KG/M

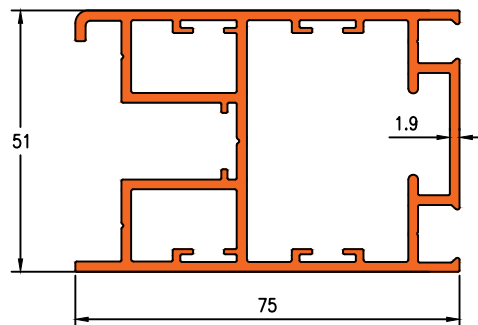



Darshan Extrusions Pvt. Ltd.

Die No.23136

1.006 KG/M

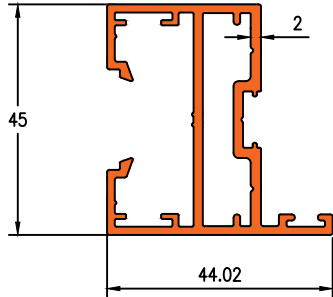

Die No.22078

0.988 KG/M

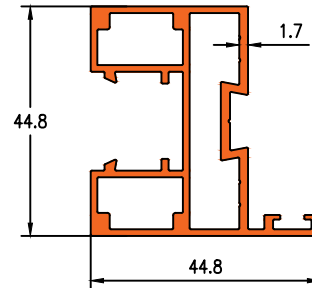

Die No.23148

1.006 KG/M

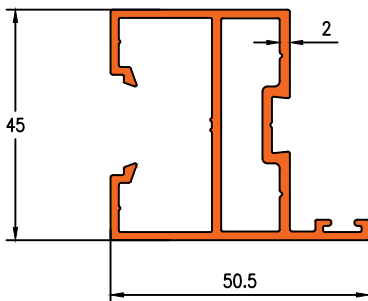

Die No.22071

0.063 KG/M

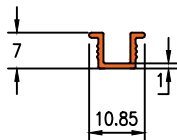

Die No.22080

0.078 KG/M

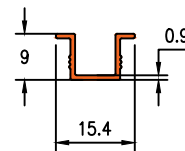

Die No.23138

0.171 KG/M

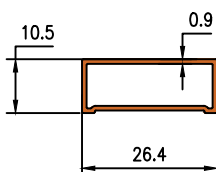

Die No.22079

0.179 KG/M

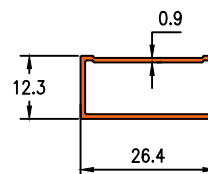



Darshan Extrusions Pvt. Ltd.

Die No.23137

0.199KG/M

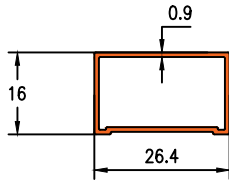

Die No.13000

0.140Kg/m

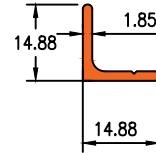

Die No.22062

0.163 KG/M

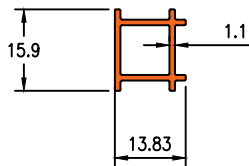

Die No.22061

0.192 KG/M

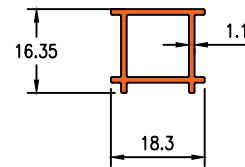

Die No.22068

0.160 KG/M

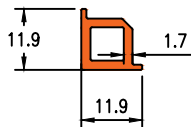

Die No.22067

0.207 KG/M

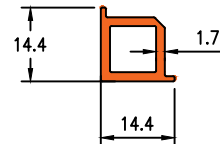

Die No.22069

0.086 KG/M

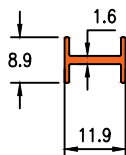

Die No.22070

0.097 KG/M

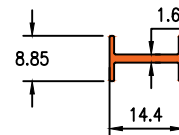



Darshan Extrusions Pvt. Ltd.

Die No.22075

0.143 KG/M

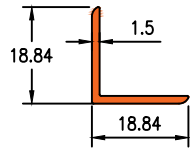

Die No.22074

0.190 KG/M

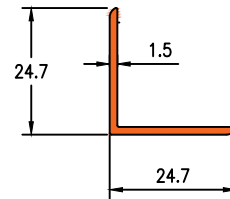

Die No.22065

1.465 KG/M

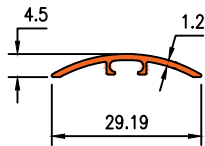

Die No.22066

0.216 KG/M

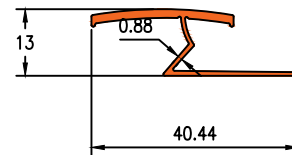

Die No.22064

0.386 KG/M

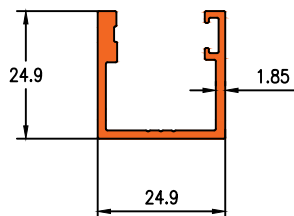

Die No.22057

0.275 KG/M

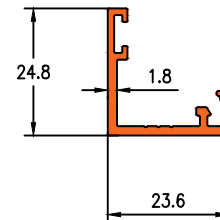

CLIP - 22058

Die No.22058

0.158 KG/M

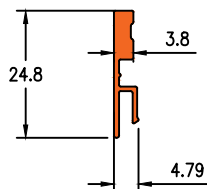



Darshan Extrusions Pvt. Ltd.

Die No.22056

0.476 KG/M

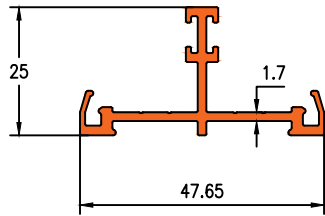

CLIP - 22055

Die No.22054

0.720 KG/M

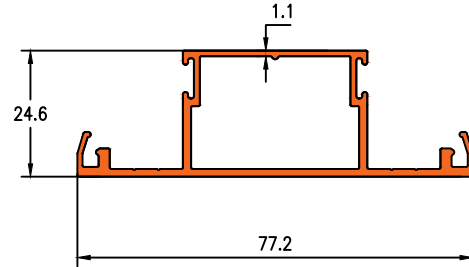

CLIP - 22055

Die No.22055

0.135 KG/M

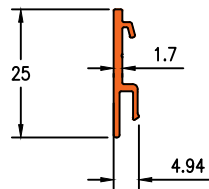

Die No.22081

0.644 KG/M

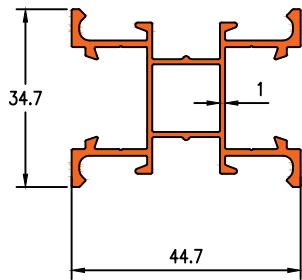

Die No.22082

0.076 KG/M

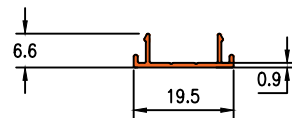



Darshan Extrusions Pvt. Ltd.

Die No.16467

0.966 Kg/m

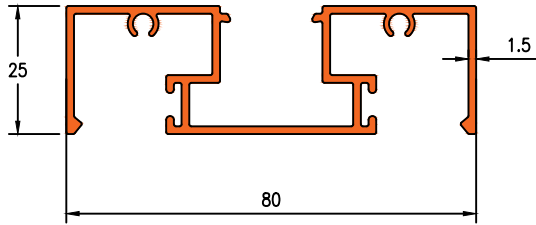

Die No.16468

0.713 Kg/m

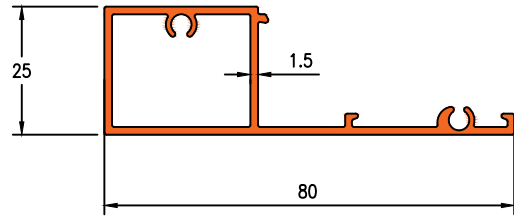

Die No.16469

0.373 Kg/m

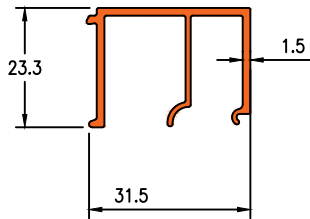

Die No.16470

0.364 Kg/m

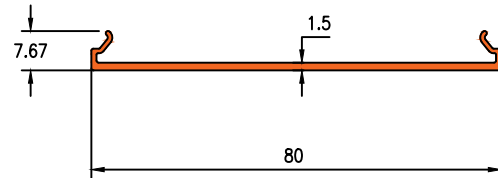

Die No.16471

0.456 Kg/m

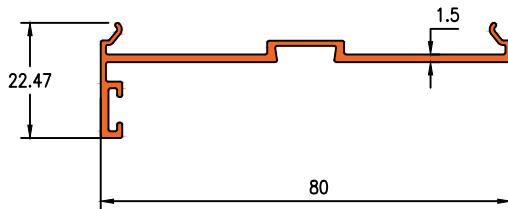

Die No.22085

0.738 Kg/m

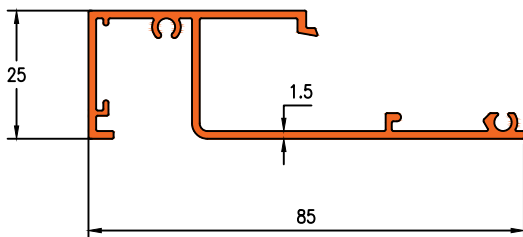

Die No.22086

0.352Kg/m

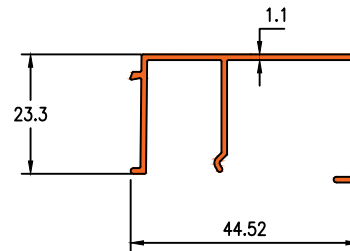



Darshan Extrusions Pvt. Ltd.

Die No.21167

1.078KG/M

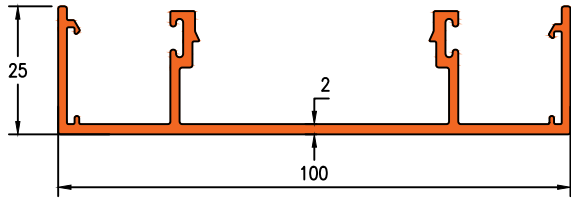

Die No.21166

0.186KG/M

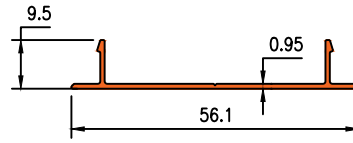

Die No.22049

1.465 KG/M

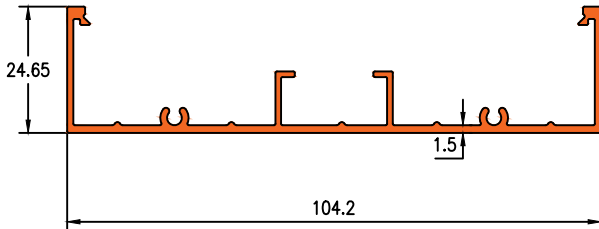

Die No.22048

0.558 KG/M

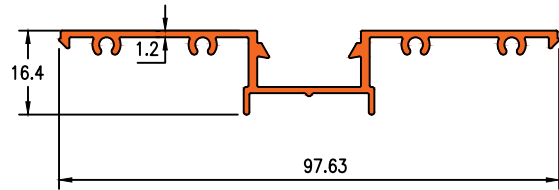

Die No.22046

1.162 KG/M

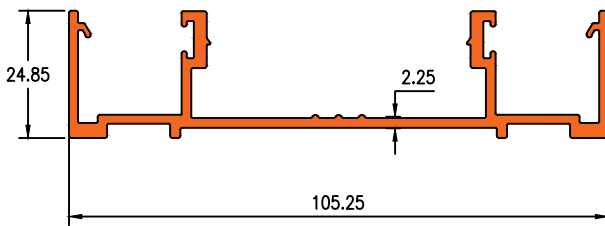

Die No. 23140

1.678 KG/M

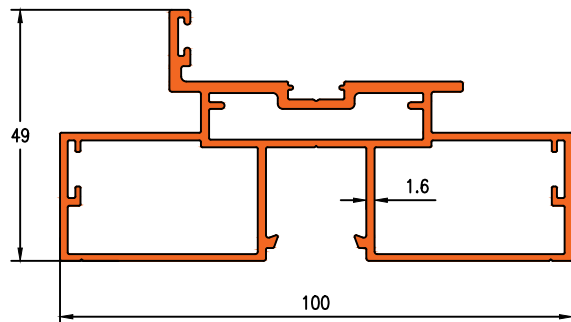

Die No.22047

1.333 KG/M

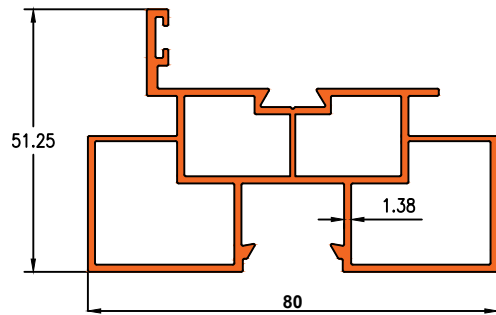



Darshan Extrusions Pvt. Ltd.

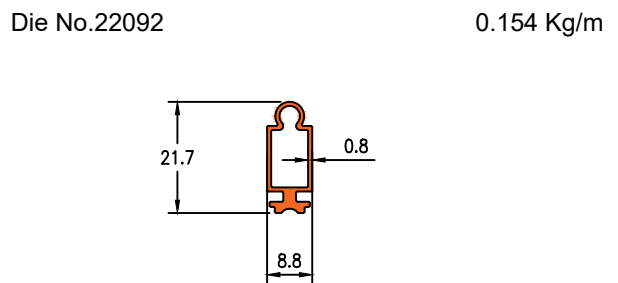
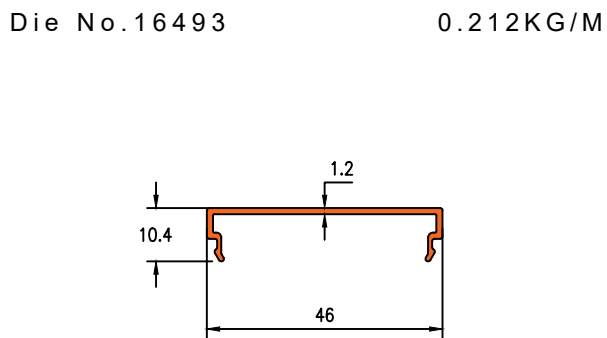
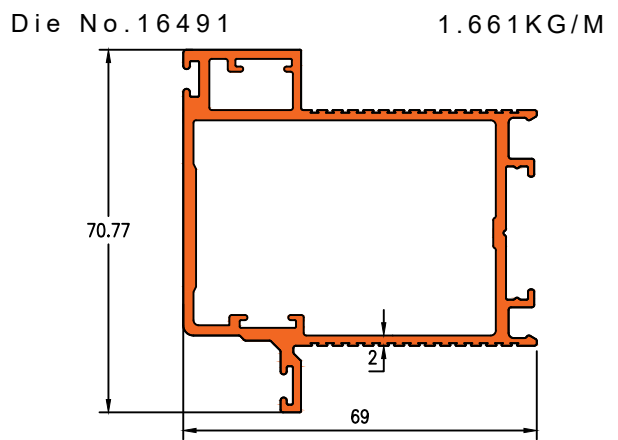
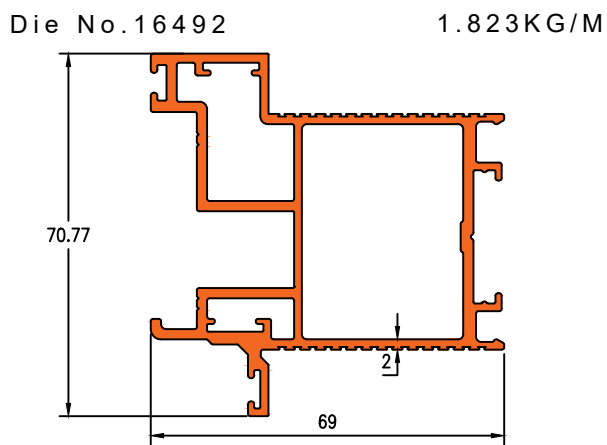
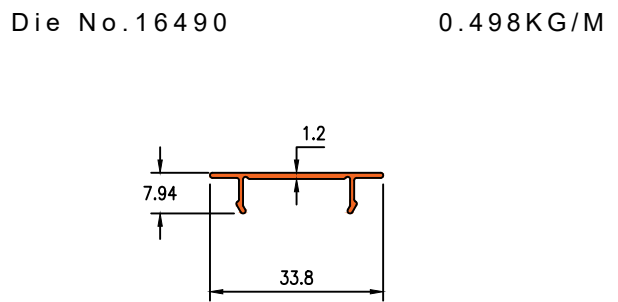
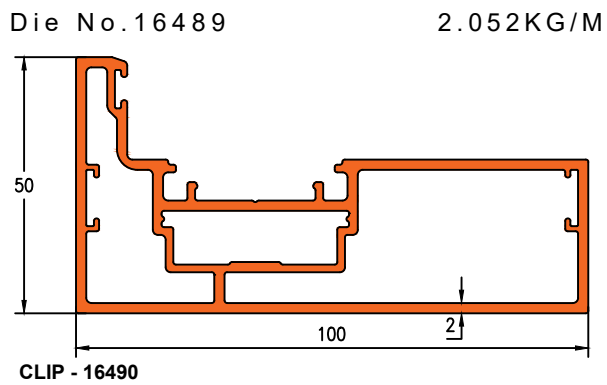
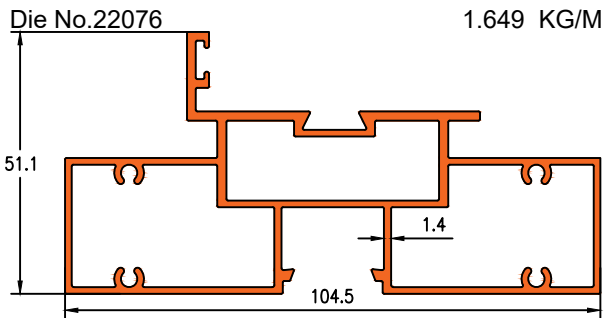



Darshan Extrusions Pvt. Ltd.

Die No.22087

0.943 Kg/m

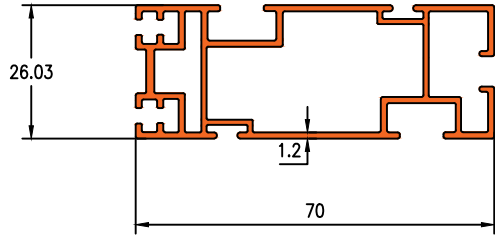

Die No.22088

1.135Kg/m

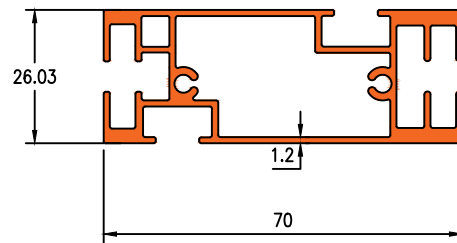

Die No.22089

0.258 Kg/m

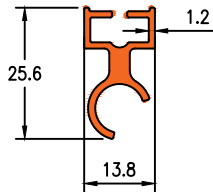

Die No.22090

0.204Kg/m

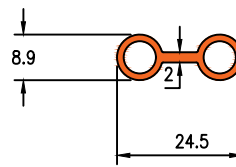

Die No.22091

0.889Kg/m

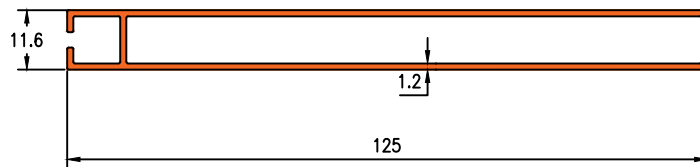

Die No.28048

0.621Kg/m

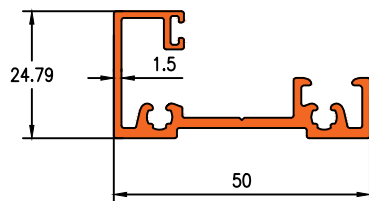

Die No.28049

0.177Kg/m

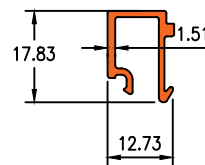



Darshan Extrusions Pvt. Ltd.

Die No.19159

0.203 Kg/m

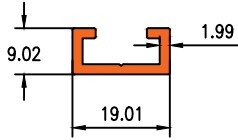

Die No.19160

1.286Kg/m

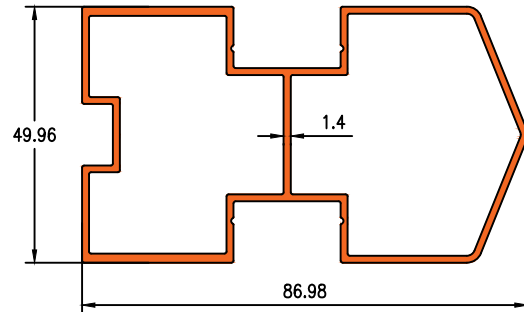

Die No.19161

0.110 Kg/m

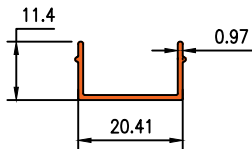

Die No.19162

0.909 Kg/m

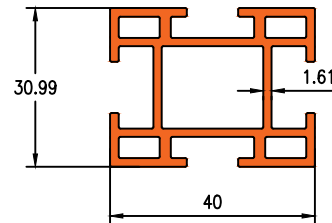

Die No.19163

0.205 Kg/m

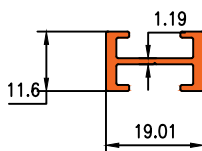



Darshan Extrusions Pvt. Ltd.

Die No.16652

0.730 Kg/m

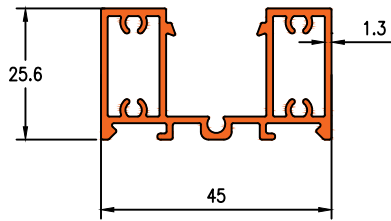

Die No.16653

0.090 Kg/m

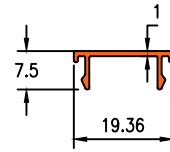

Die No.16654

0.701 Kg/m

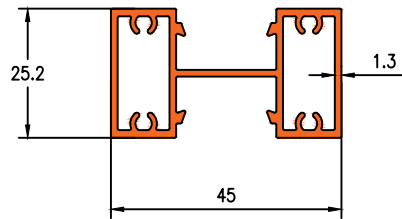

Die No.16655

0.501 Kg/m

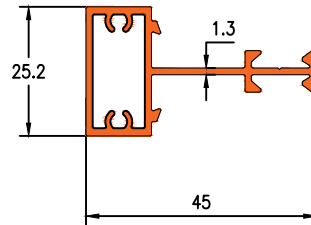

Die No.16656

0.132 Kg/m

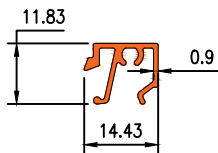

Die No.16657

1.019 Kg/m

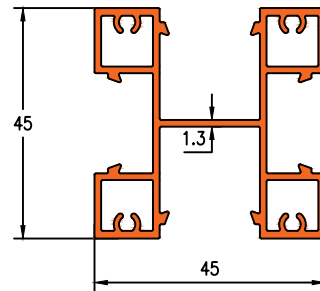

Die No.16658

0.706 Kg/m

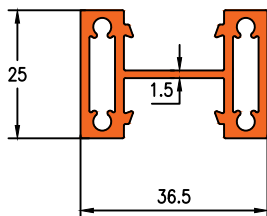



Darshan Extrusions Pvt. Ltd.

Die No.23151

0.478 Kg/m

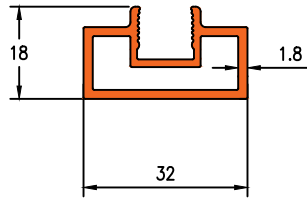

Die No.23152

0.655 Kg/m

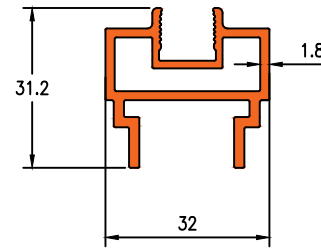

Die No.23153

0.287 Kg/m

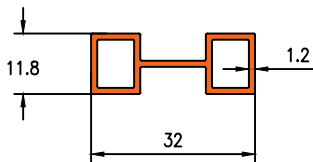

Die No.23154

0.606 Kg/m

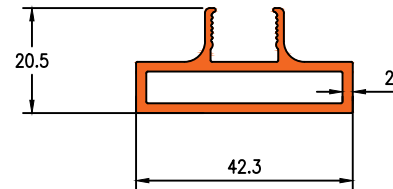

Die No.23155

0.759 Kg/m

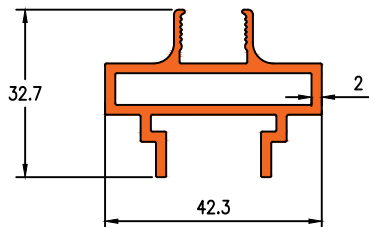

Die No.23156

0.532 Kg/m

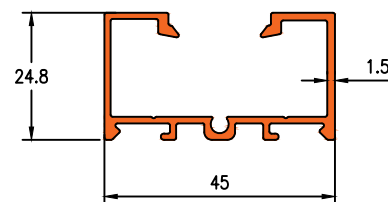

Die No.23157

0.418 Kg/m

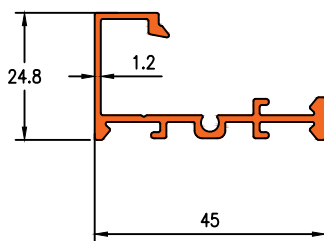

Die No.23158

0.160 Kg/m

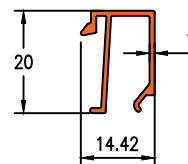



Darshan Extrusions Pvt. Ltd.

Die No.23151

0.478KG/M

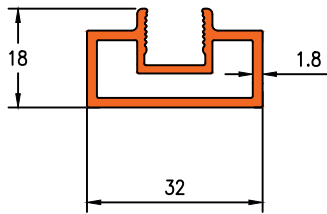

Die No.23152

0.655KG/M

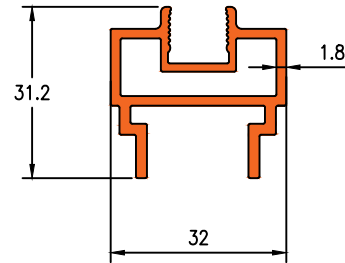

Die No.23153

0.287KG/M

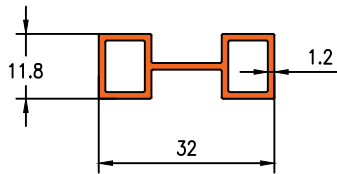

Die No.23154

0.606KG/M

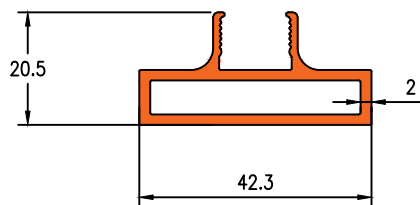

Die No.23155

0.759KG/M

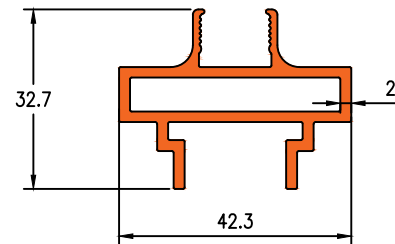

Die No.19658

0.621KG/M

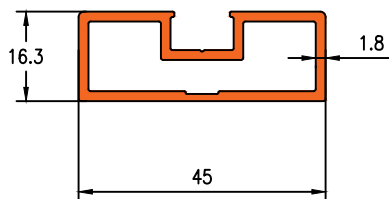

Die No.19657

0.790KG/M

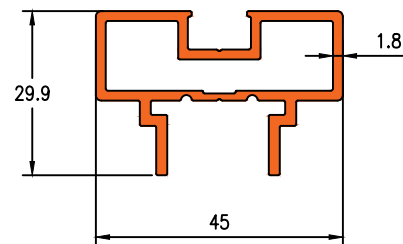



Darshan Extrusions Pvt. Ltd.

Die No.20053

0.631KG/M

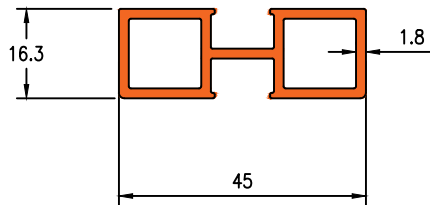

Die No.23159

0.751KG/M

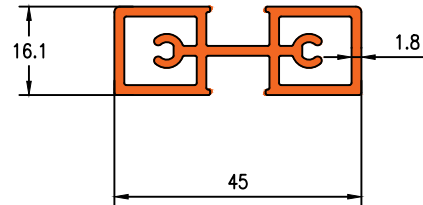

Die No.23115

0.568 KG/M

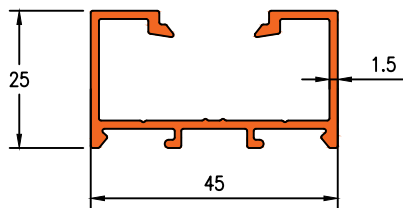

COVER - 23102

Die No.23156

0.532KG/M

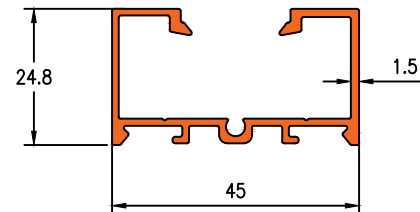

COVER - 23102

Die No.23116

0.457KG/M

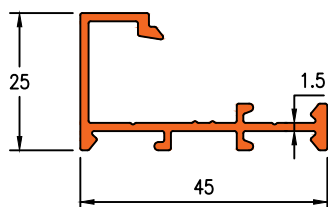

CLIP - 23117
COVER - 23102

Die No.23117

0.164KG/M

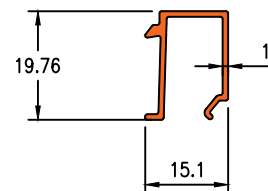

Die No.23157

0.418KG/M

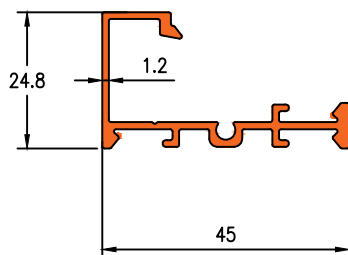

CLIP - 23158

Die No.23158

0.160KG/M

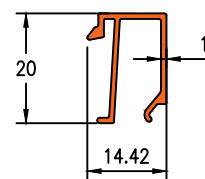



Darshan Extrusions Pvt. Ltd.

Die No.23102

0.169 KG/M

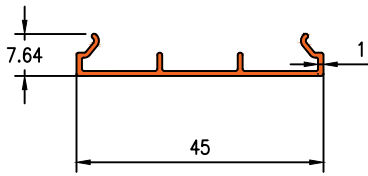

Die No.23101

0.265 KG/M

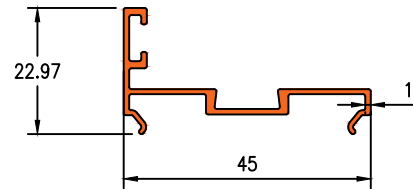

Die No.22052

0.457 KG/M

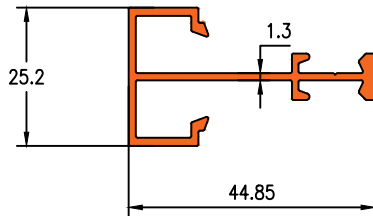

Die No.22053

0.122KG/M

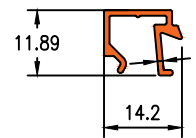

Die No.16655

0.501KG/M

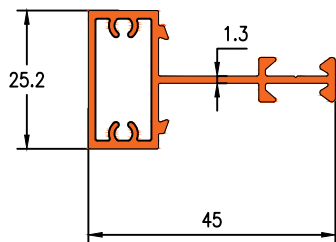

CLIP - 16656
COVER - 16653

Die No.16656

0.132KG/M

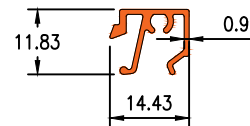

Die No.16652

0.730KG/M

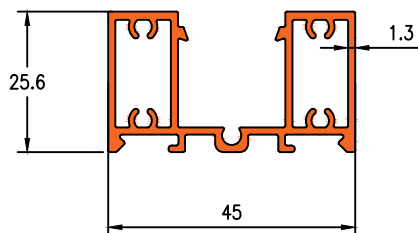

COVER - 16653

Die No.16653

0.090KG/M

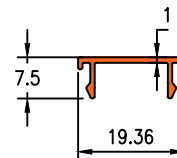



Darshan Extrusions Pvt. Ltd.

Die No.16654

0.701KG/M

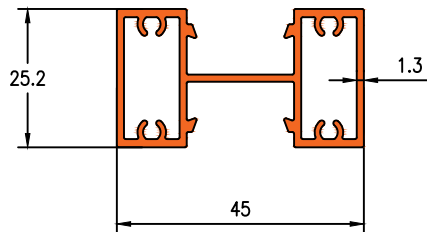

COVER - 16653

Die No.16657

1.019KG/M

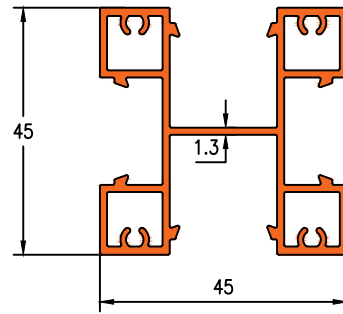

COVER - 16653

Die No.16658

0.706KG/M

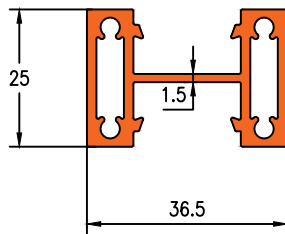

COVER - 16653

Die No.23134

1.050KG/M

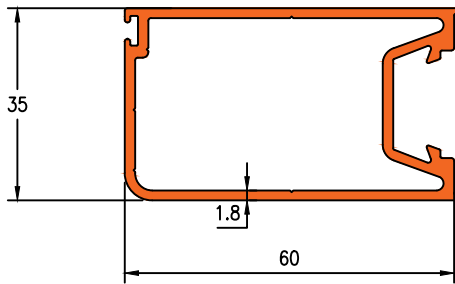

Die No.22051

1.053KG/M

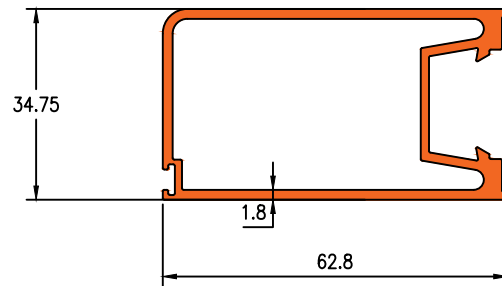

Die No.16590

1.059KG/M

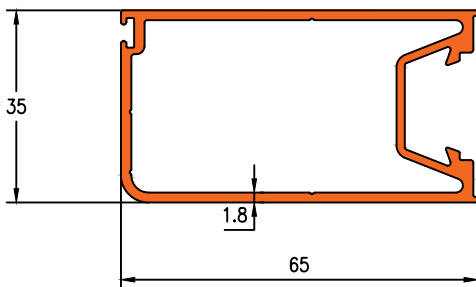

Die No.22050

1.233KG/M

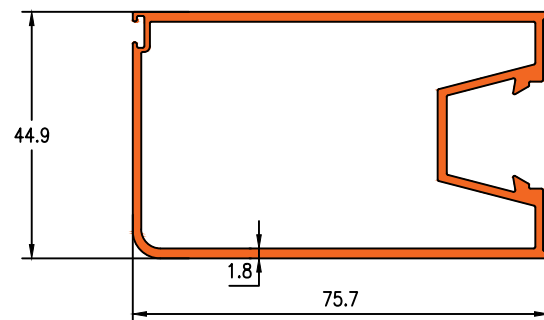



Darshan Extrusions Pvt. Ltd.

Die No.22083

0.773KG/M

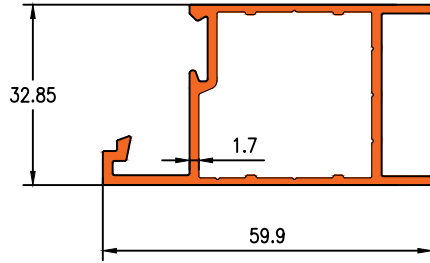

Die No.22084

0.177KG/M

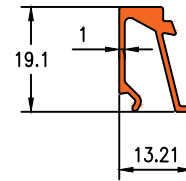

Die No.23149

0.871KG/M

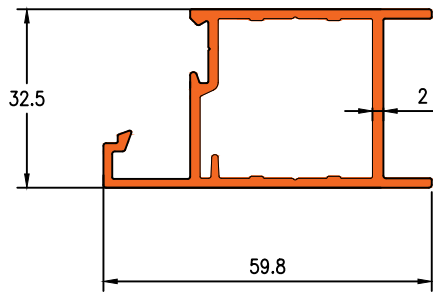

Die No.23150

0.177KG/M

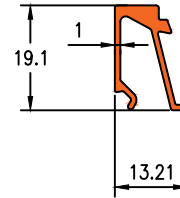

Die No.22059

1.073KG/M

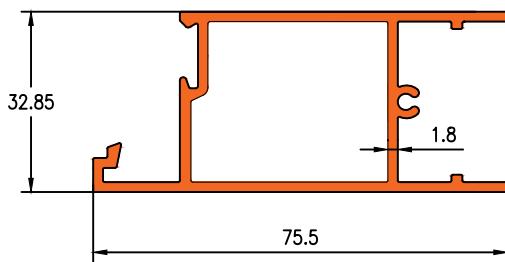

CLIP - 22060

Die No.16670

1.197KG/M

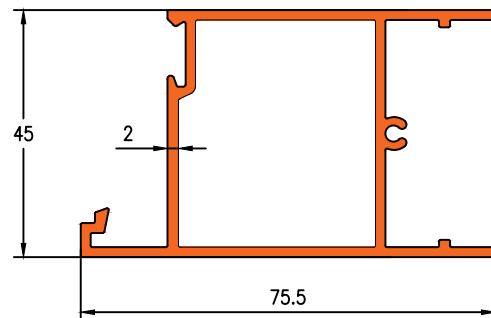

CLIP - 22060

Die No.22060

0.177KG/M

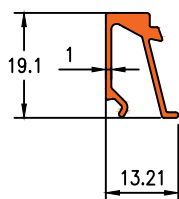



Die No.23135

1.214KG/M

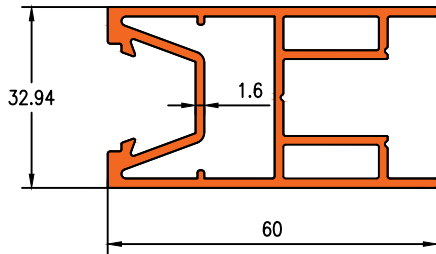

Die No.16510

1.535KG/M

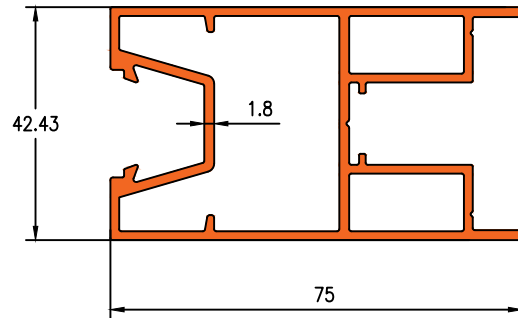

Die No.22045

1.465KG/M

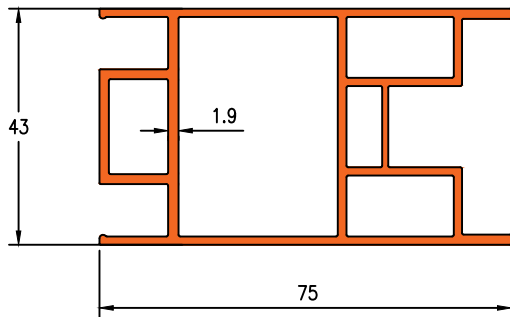

Die No.16494

1.841KG/M

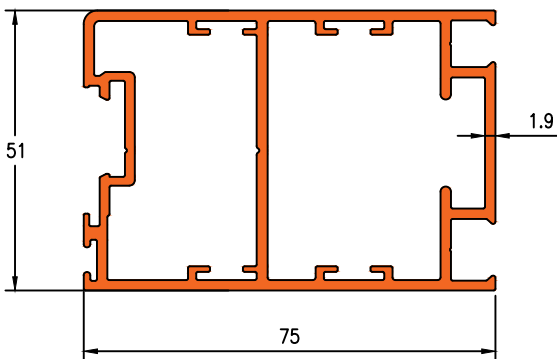

Die No.16495

1.923KG/M

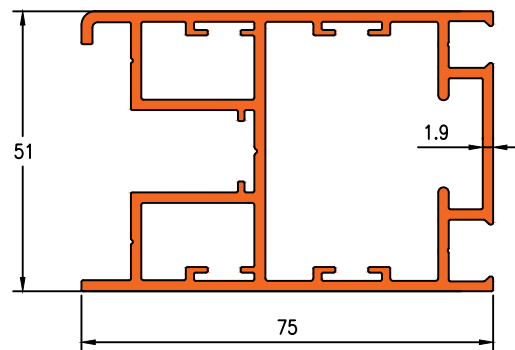



Darshan Extrusions Pvt. Ltd.

Die No.23136

1.006KG/M

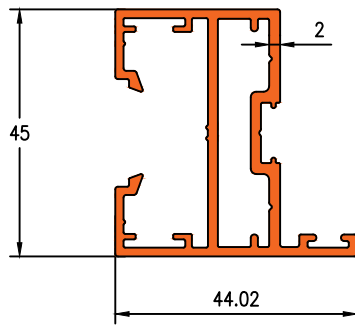

Die No.22078

0.988KG/M

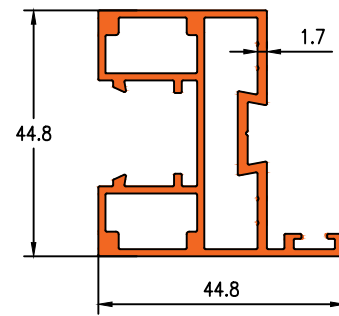

Die No.23148

1.006KG/M

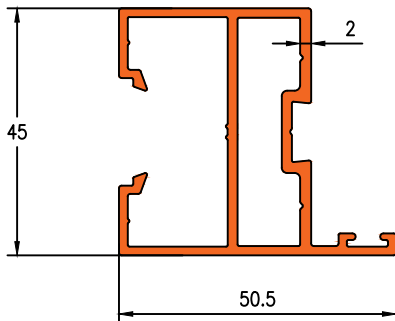

Die No.22071

0.063KG/M

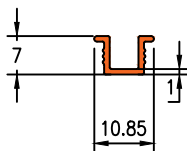

Die No.22080

0.078KG/M

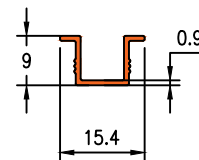

Die No.21230

0.318KG/M

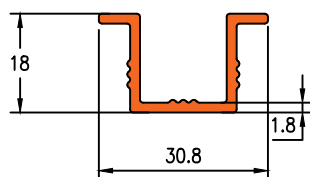

Die No.23138

0.171KG/M

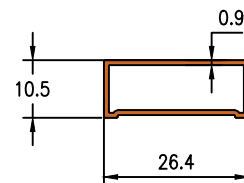



Darshan Extrusions Pvt. Ltd.

Die No.22079

0.179KG/M

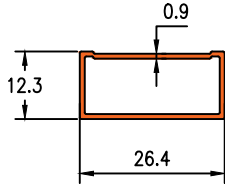

Die No.23137

0.199KG/M

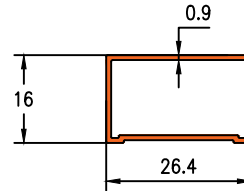

Die No.22062

0.163KG/M

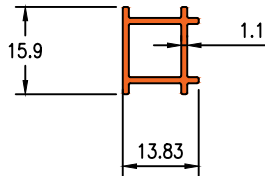

Die No.22061

0.192KG/M

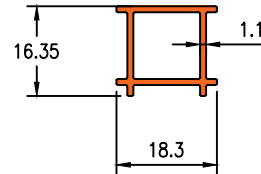

Die No.22068

0.160KG/M

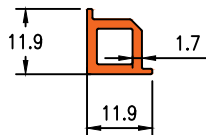

Die No.22067

0.207KG/M

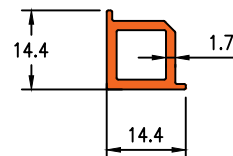

Die No.22069

0.086KG/M

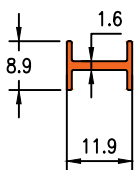

Die No.22070

0.097KG/M

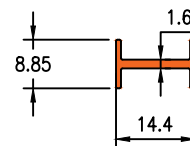



Darshan Extrusions Pvt. Ltd.

Die No.22075

0.143KG/M

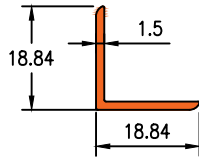

Die No.22074

0.190KG/M

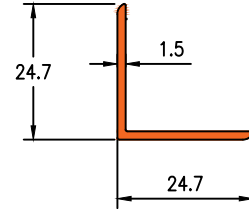

Die No.22065

1.465KG/M

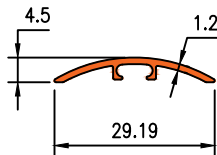

Die No.22066

0.216KG/M

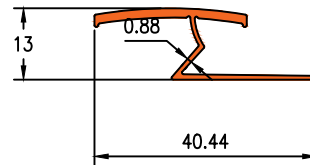

Die No.22064

0.386KG/M

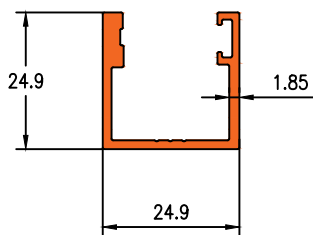

Die No.22057

0.275KG/M

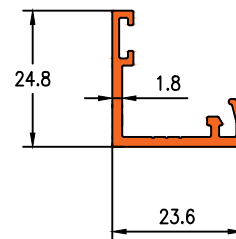

CLIP - 22058

Die No.22058

0.158KG/M

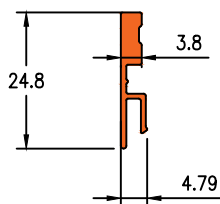



Die No.22056

0.476KG/M

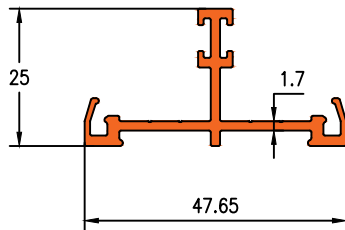

CLIP - 22055

Die No.22054

0.720KG/M

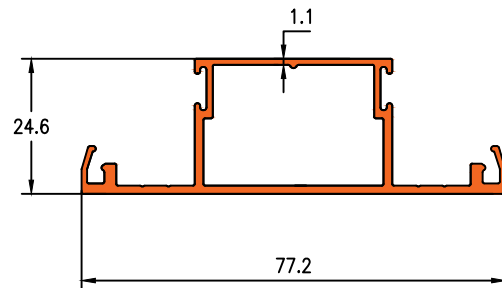

CLIP - 22055

Die No.22055

0.135KG/M

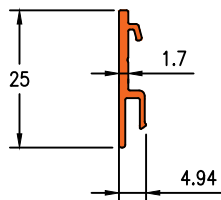

Die No.22081

0.644KG/M

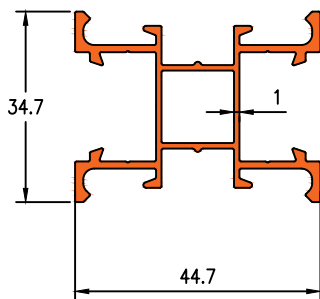

Die No.22082

0.076KG/M

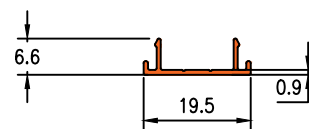

Die No.21167

1.078KG/M

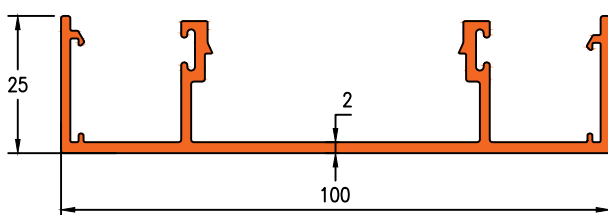

Die No.21166

0.186KG/M

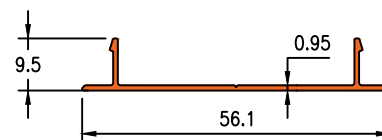



Darshan Extrusions Pvt. Ltd.

Die No.22049

1.465KG/M

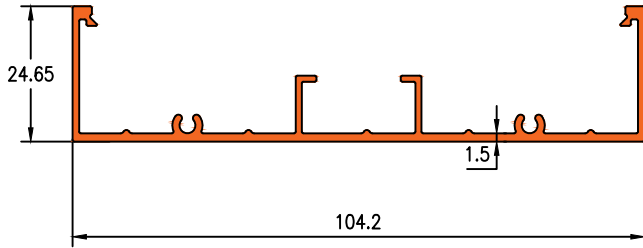

Die No.22048

0.558KG/M

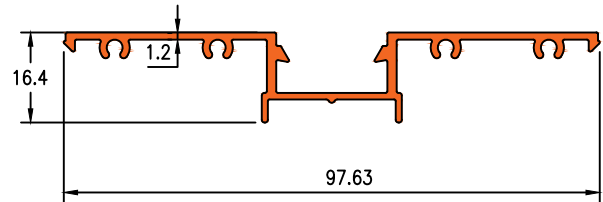

Die No.22046

1.162KG/M

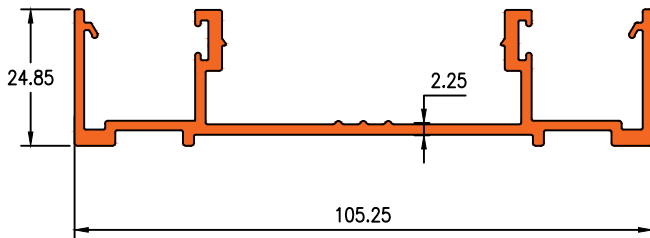

Die No.23140

1.678KG/M

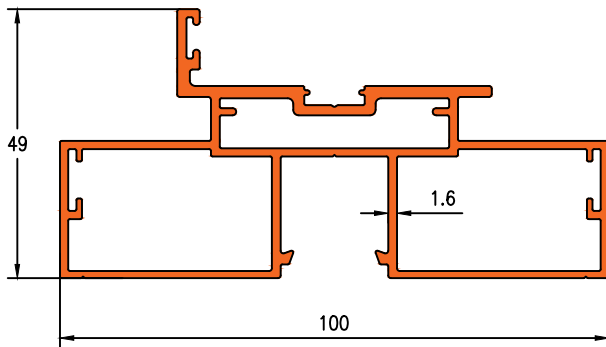

Die No.22047

1.333KG/M

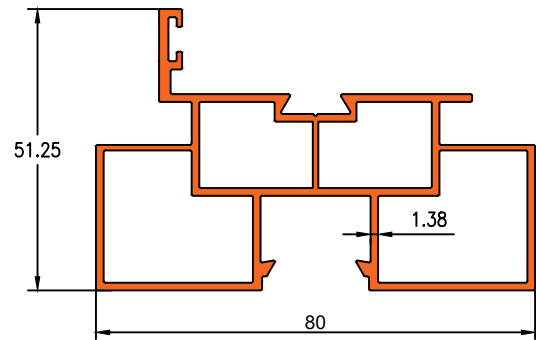

Die No.22076

1.649KG/M

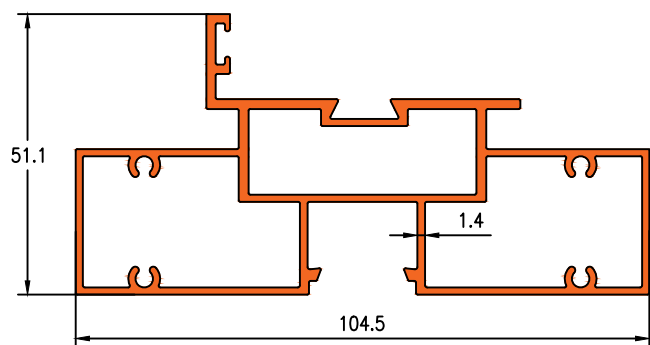



Die No. 16489

2.052KG/M

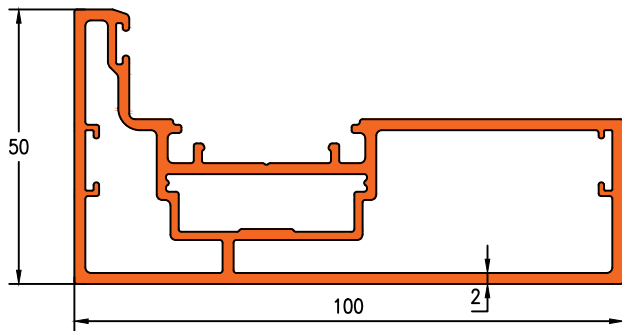

CLIP - 16490

Die No. 16490

0.498KG/M

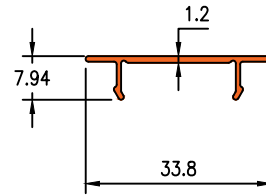

Die No. 16492

1.823KG/M

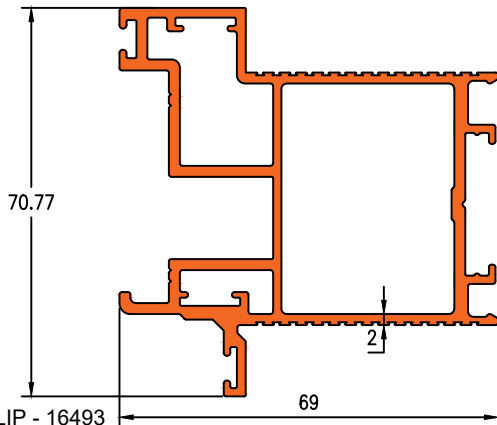

CLIP - 16493

Die No. 16491

1.661KG/M

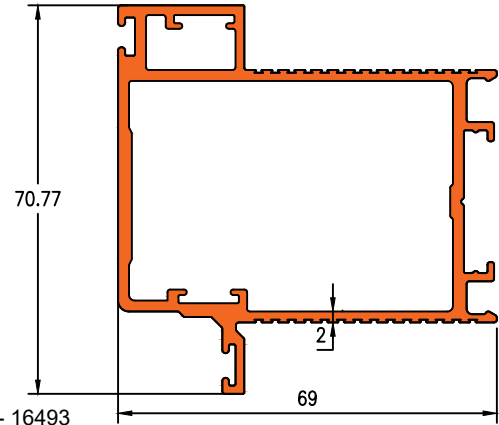

CLIP - 16493

Die No. 16493

0.212KG/M

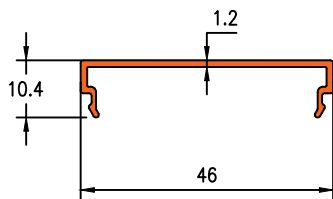



Die No.23127

1.321KG/M

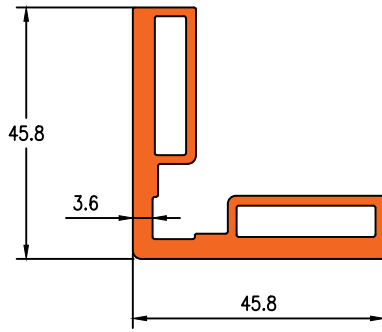

Die No.23128

0.390KG/M

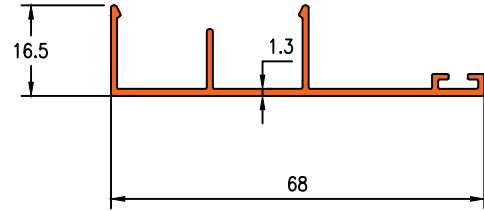

Die No.23129

0.799KG/M

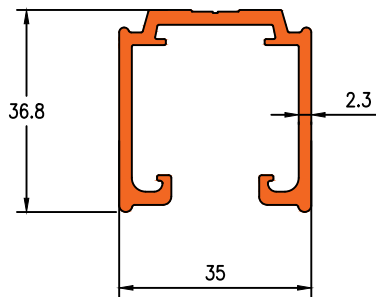



Die No.19759

0.671KG/M

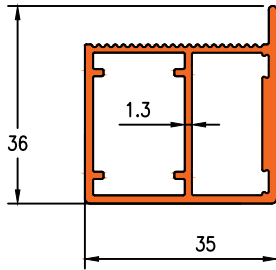

Die No.19760

0.976KG/M

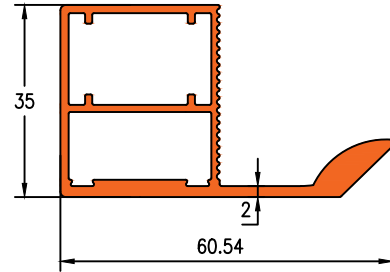

Die No.23038

0.498KG/M

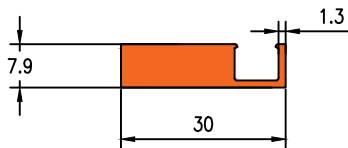

Die No.23039

0.646KG/M

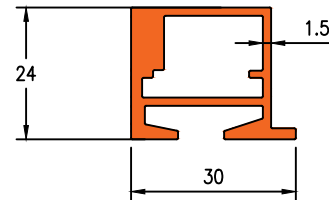

Die No.23040

0.692KG/M

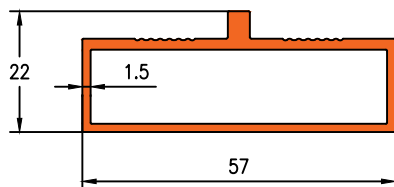

Die No.23041

0.379KG/M

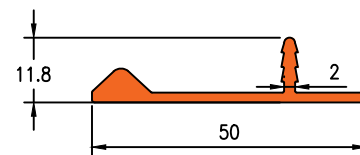

Die No.23042

1.778KG/M

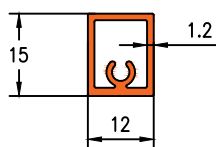

Die No.23043

0.743KG/M

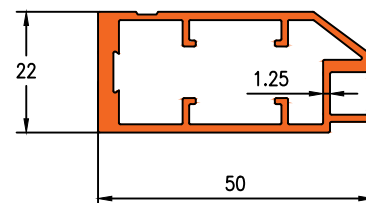



Darshan Extrusions Pvt. Ltd.

Die No.23044

3.392KG/M

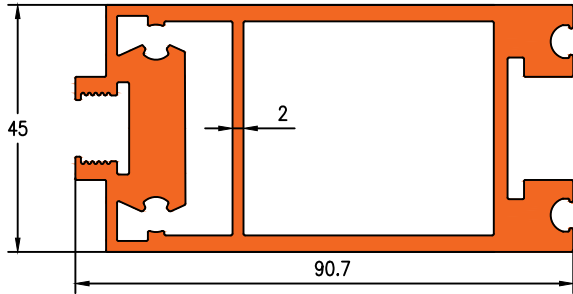

Die No.23045

1.313KG/M

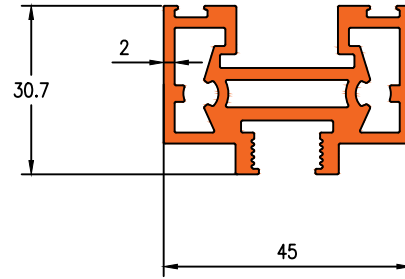

Die No.23046

0.600KG/M

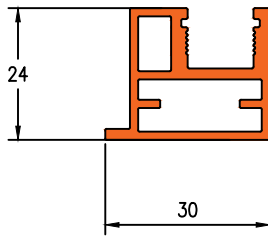

Die No.23047

1.127KG/M

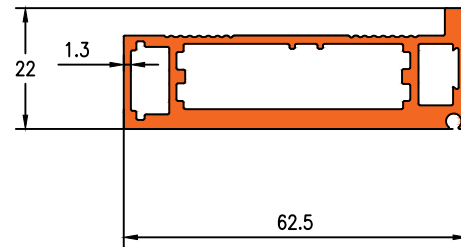

Die No.23048

1.282KG/M

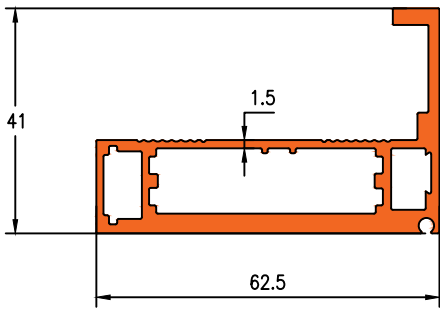

Die No.23049

1.382KG/M

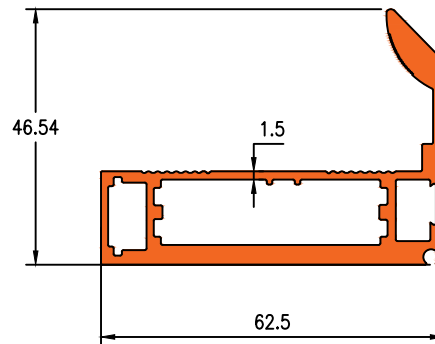

Die No.23050

1.483KG/M

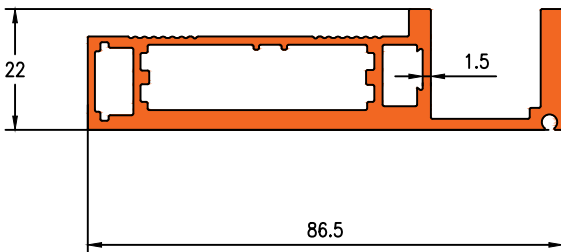

Die No.23051

1.206KG/M

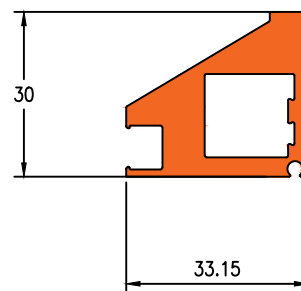



Darshan Extrusions Pvt. Ltd.

Die No.23052

0.381KG/M

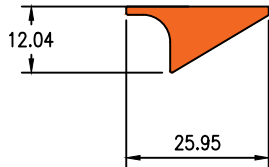

Die No.23053

0.233KG/M

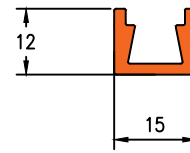

Die No.23054

0.104KG/M

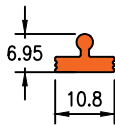

Die No.23055

0.634KG/M

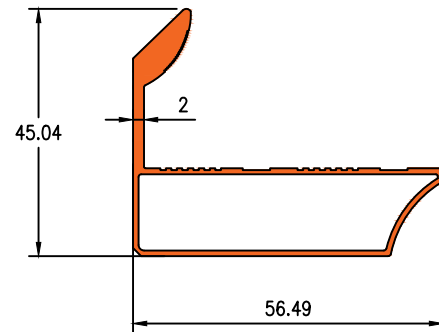

Die No.23056

0.540KG/M

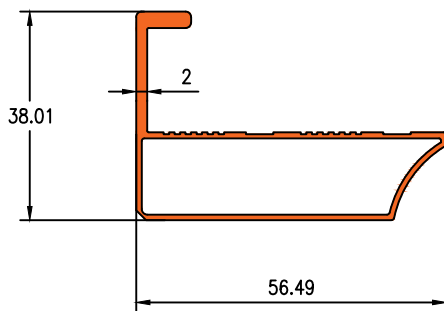

Die No.23057

0.523KG/M

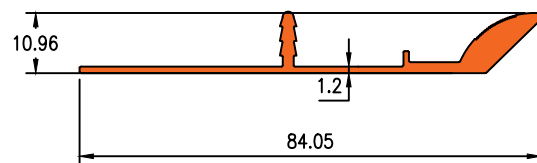

Die No.23058

0.264KG/M

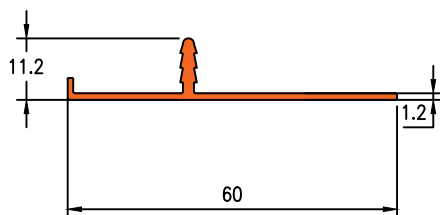

Die No.23059

0.431KG/M

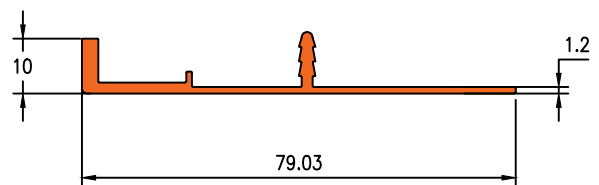



Die No.23076

0.498KG/M

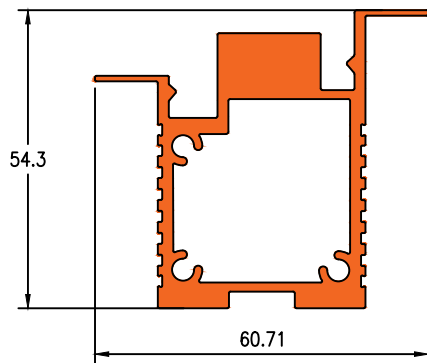

Die No.23077

0.413KG/M

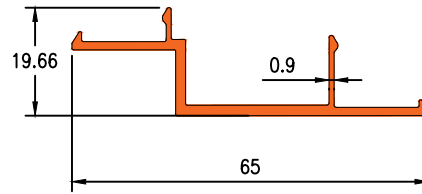

Die No.23078

0.988KG/M

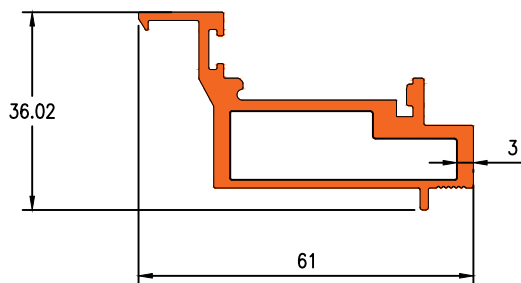

Die No.23079

0.901KG/M

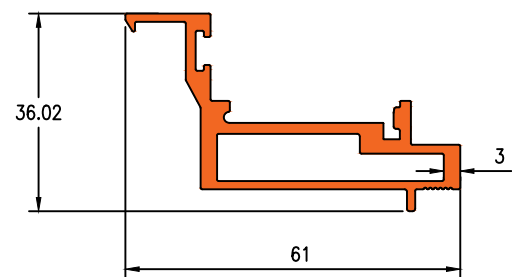

Die No.23080

0.153KG/M

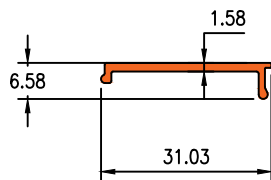

Die No.23081

1.354KG/M

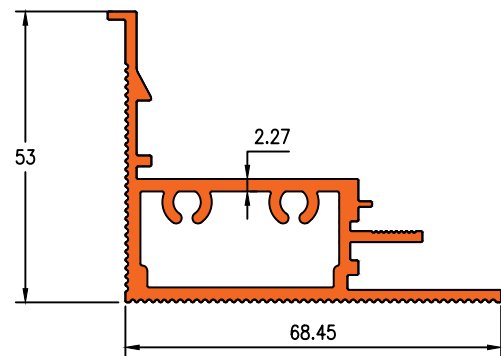



Die No.16481

0.802KG/M

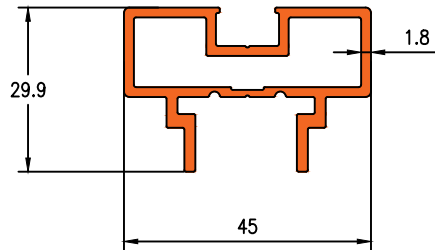

Die No.16619

1.204KG/M

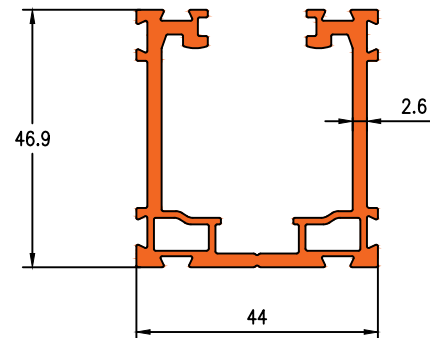

Die No.16620

0.344KG/M

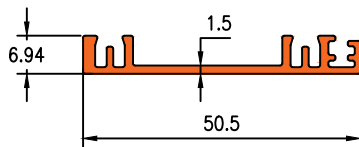

Die No.16635

0.713KG/M

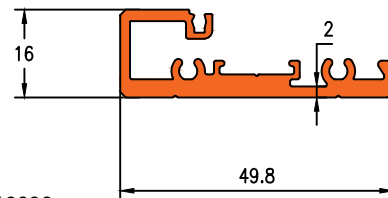

CLIP - 16636
COVER - 16639

Die No.16636

0.148KG/M

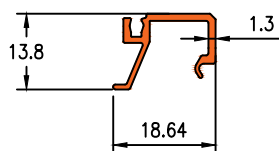

Die No.16639

0.491KG/M

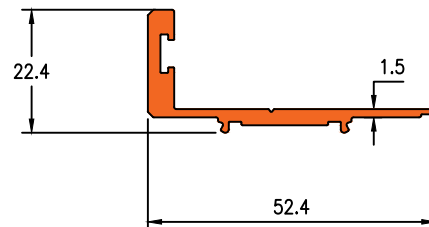

Die No.16637

1.094KG/M

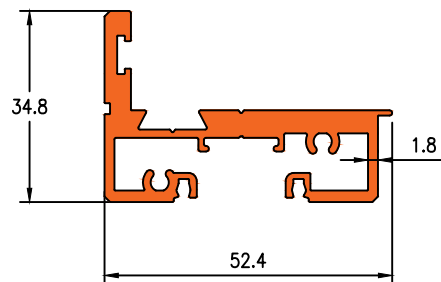

Die No.16638

1.719KG/M

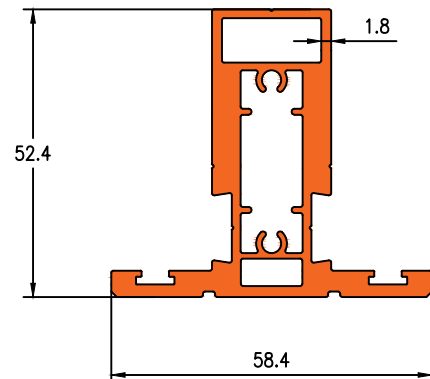



Darshan Extrusions Pvt. Ltd.

Die No.16640

1.205KG/M

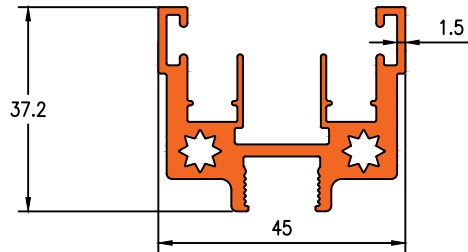

Die No.16641

1.523KG/M

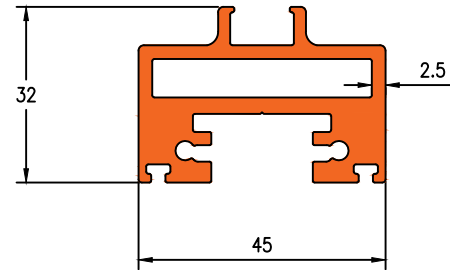

Die No.16642

0.827KG/M

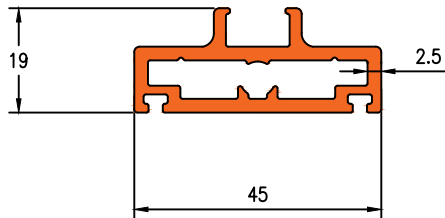

Die No.23073

1.564KG/M

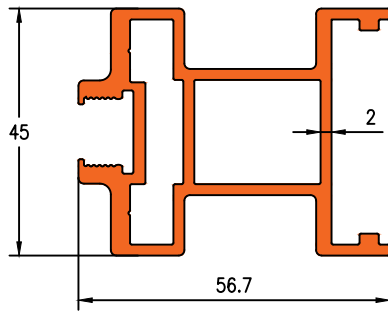

Die No.23061

0.752KG/M

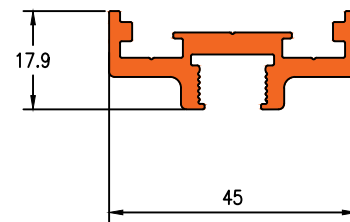

Die No.16645

0.162KG/M

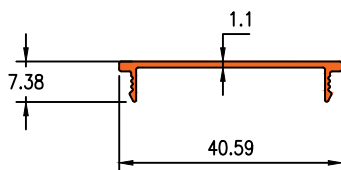



Darshan Extrusions Pvt. Ltd.

Die No.23082

1.414KG/M

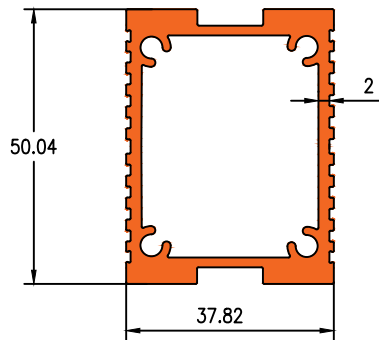

Die No.23083

0.982KG/M

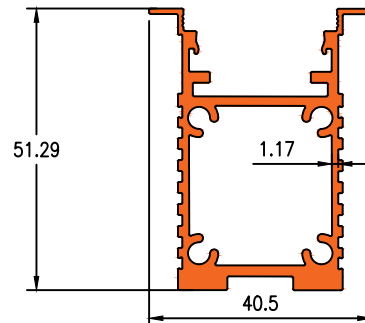

Die No.23084

0.284KG/M

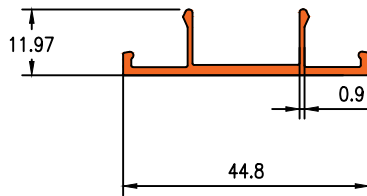

Die No.23085

0.271KG/M

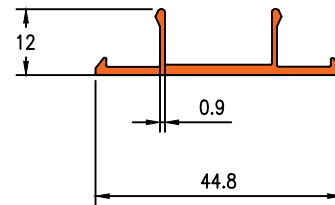

Die No.23074

0.779KG/M

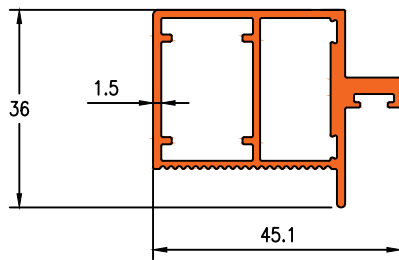

Die No.23075

0.857KG/M

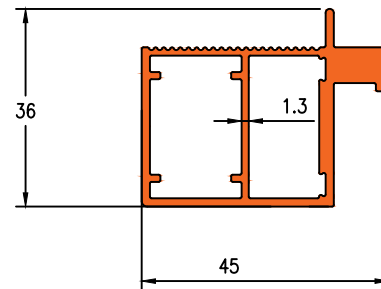

Die No.23068

0.781KG/M

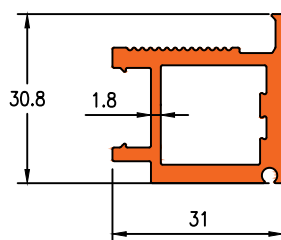

Die No.23069

0.942KG/M

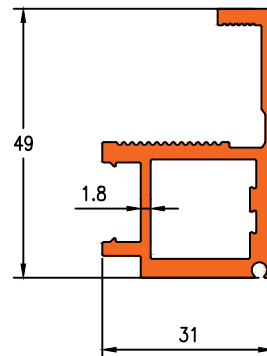



Die No.23070

0.974KG/M

Die No.23071

0.064KG/M

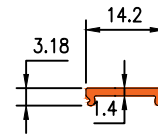
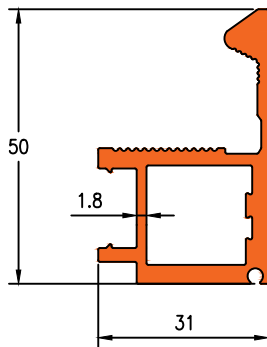

Die No.23072

0.235KG/M

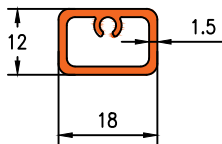

Die No.23087

3.703KG/M

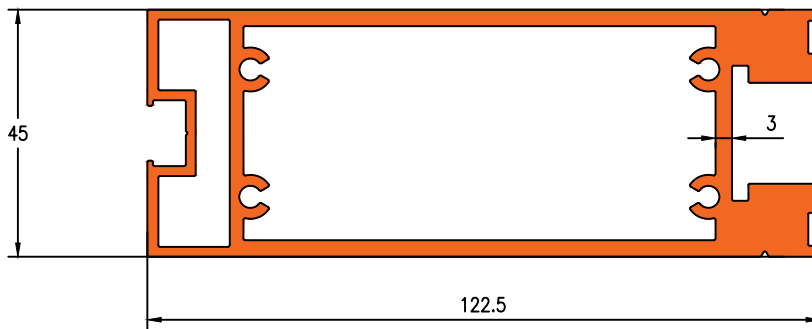

Die No.23088

1.328KG/M

Die No.23089

0.210KG/M

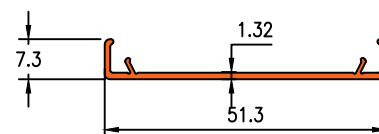
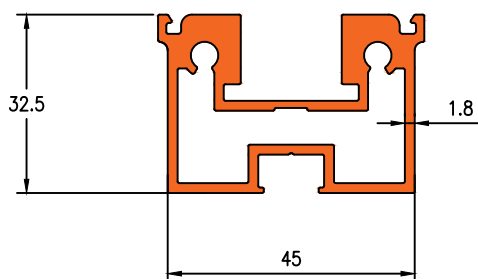



Darshan Extrusions Pvt. Ltd.

Die No.23090

0.700KG/M

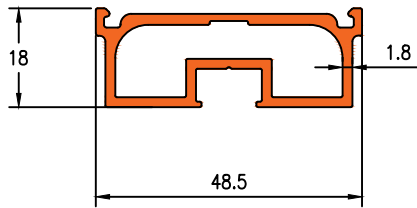

Die No.16498

0.890KG/M

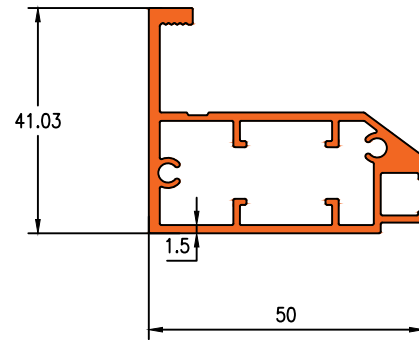

Die No.16499

0.300KG/M

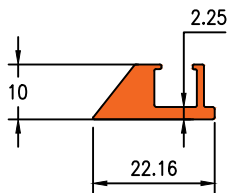

Die No.16496

0.158KG/M

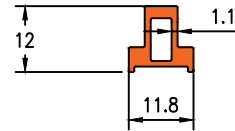

Die No.16497

0.146KG/M

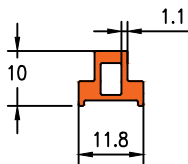

Die No.16555

0.720KG/M

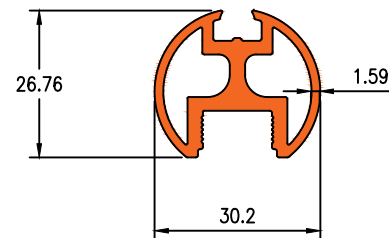

Die No.16556

0.603KG/M

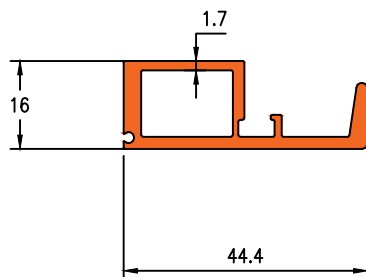

Die No.16557

0.618KG/M

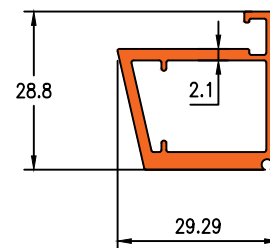



Darshan Extrusions Pvt. Ltd.

Die No.19817

0.863KG/M

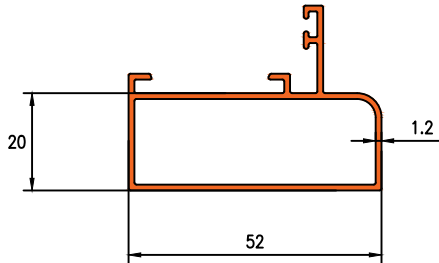

Die No.21216

0.889KG/M

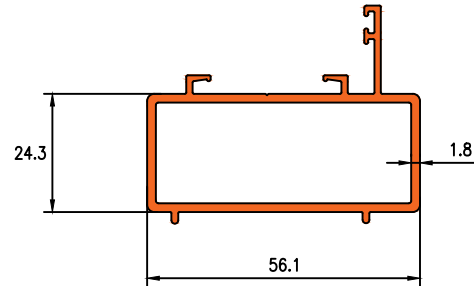

Die No.23123

0.919Kg/m

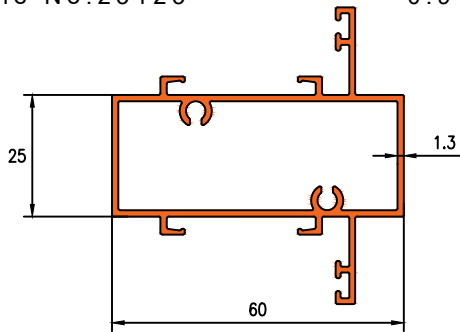

Die No.21088

0.791KG/M

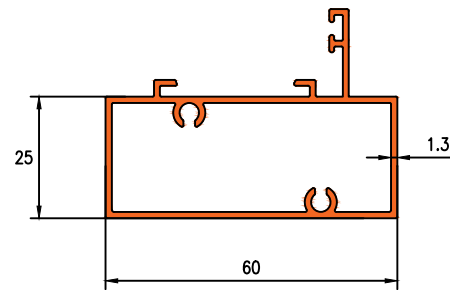

Die No.20044

0.893Kg/m

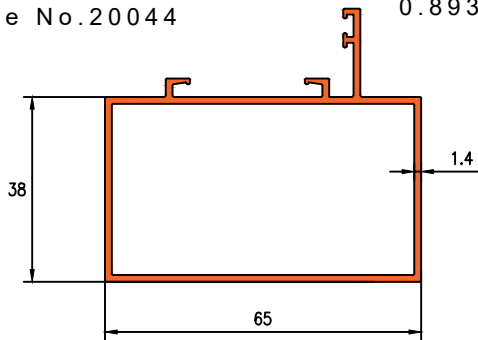

Die No.16460

0.714Kg/m

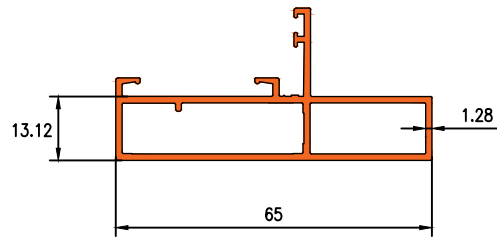

Die No.16112

0.968KG/M

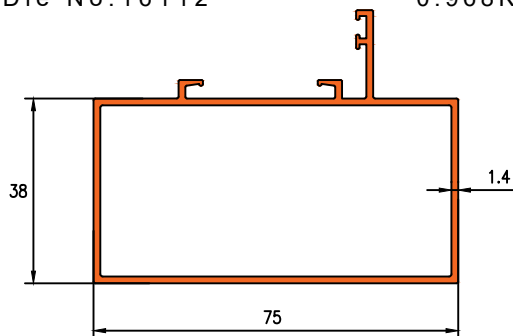

Die No.19438

0.863Kg/m

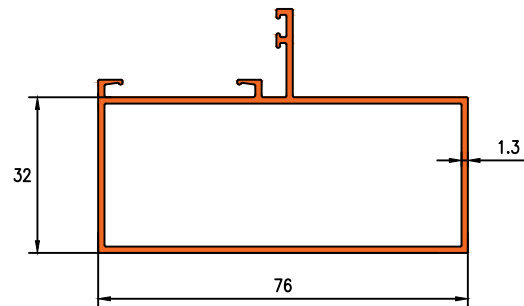

40 MM SERIES



Darshan Extrusions Pvt. Ltd.

Die No.19651

0.945KG/M

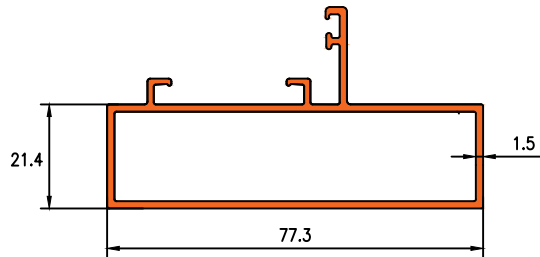

Die No.19816

0.824KG/M

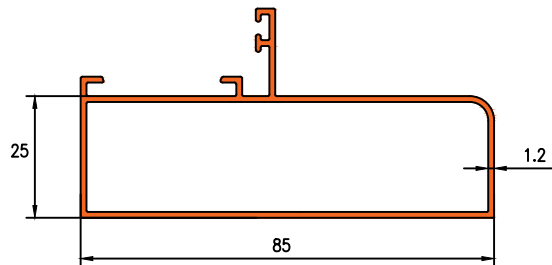

Die No.23122

1.058KG/M

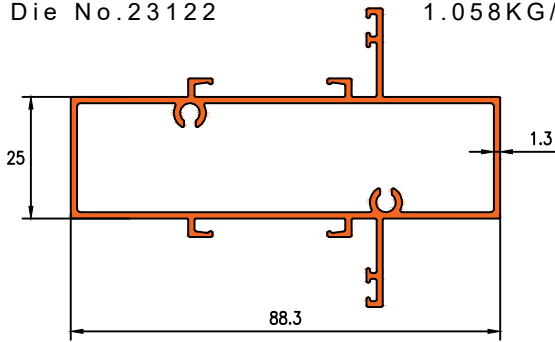

Die No.21112

0.905KG/M

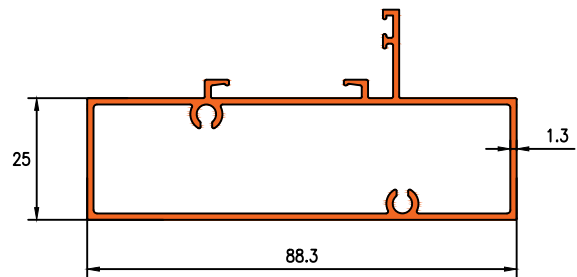

Die No.21217

1.218 KG/M

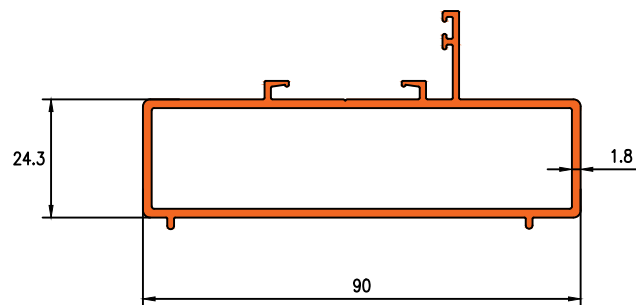

Die No.21089

1.058KG/M

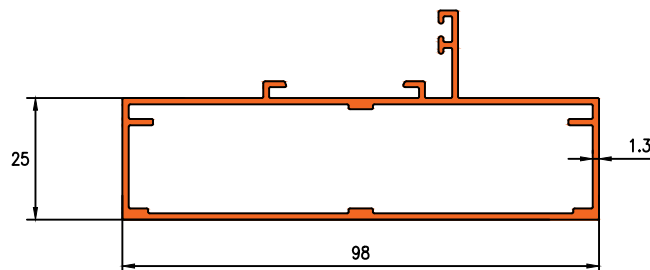

40 MM SERIES



Darshan Extrusions Pvt. Ltd.

Die No.16459

0.977 KG/M

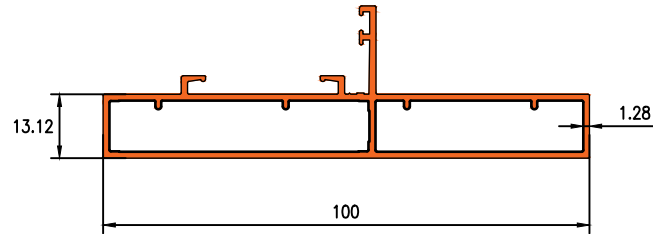

Die No.20043

1.157 KG/M

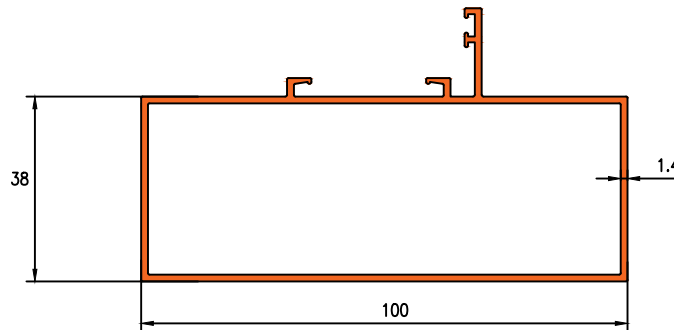

Die No.21164

0.966 KG/M

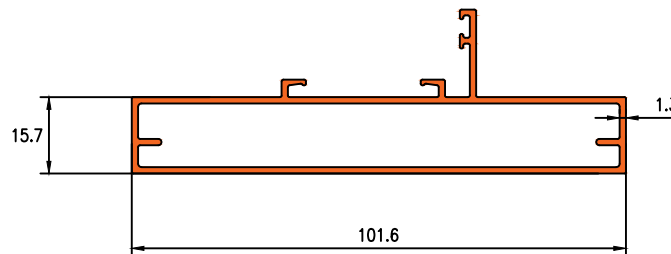

Die No.19439

1.144 KG/M

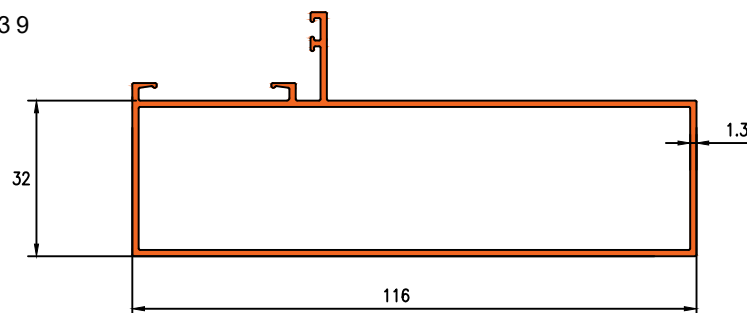

40 MM SERIES



Darshan Extrusions Pvt. Ltd.

Die No.19956

1.101KG/M

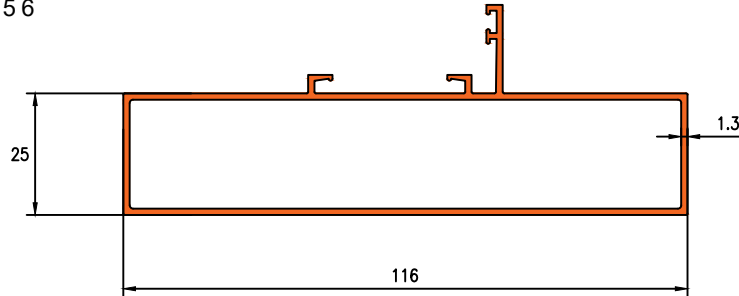

Die No.16111

1.367KG/M

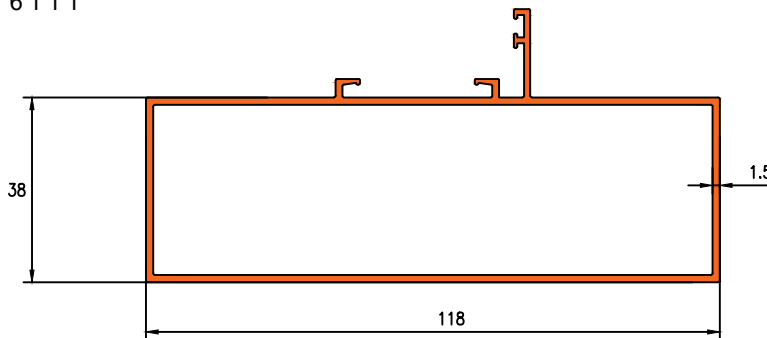

Die No.21069

1.131KG/M

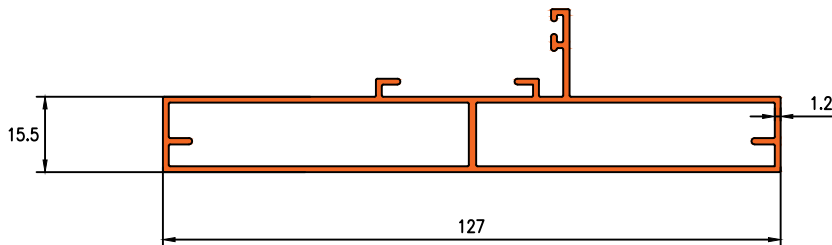

Die No.16601

1.269KG/M

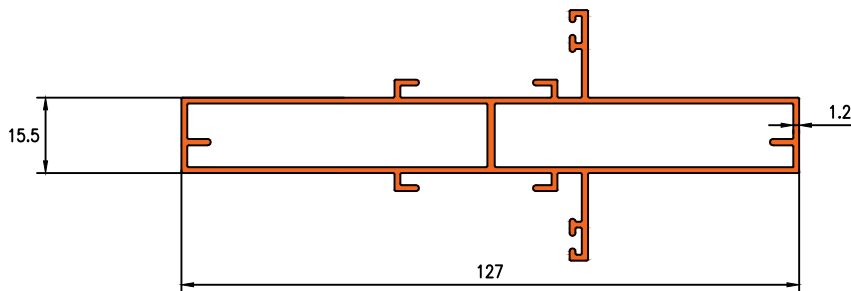

UNITIZED SYSTEM



Darshan Extrusions Pvt. Ltd.

Die No.16253

1.420KG/M

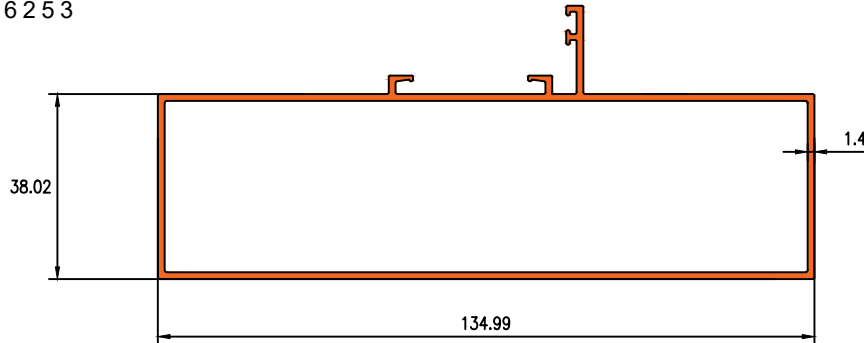

Die No.4006

0.207KG/M

Die No.4007

0.202KG/M

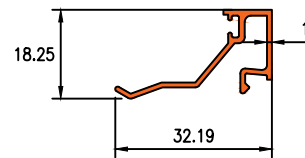
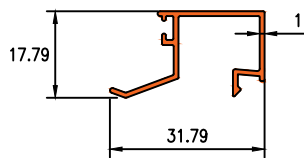

Die No.19489

0.197KG/M

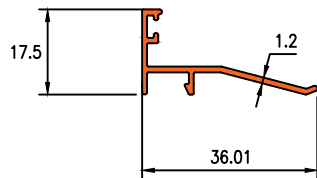



Darshan Extrusions Pvt. Ltd.

Die No.19451

0.730Kg/m

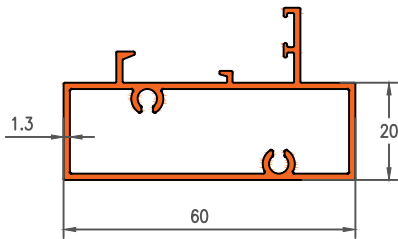

Die No.19448

0.906Kg/m

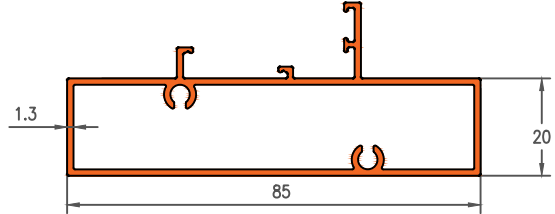

Die No.19450

0.844 Kg/m

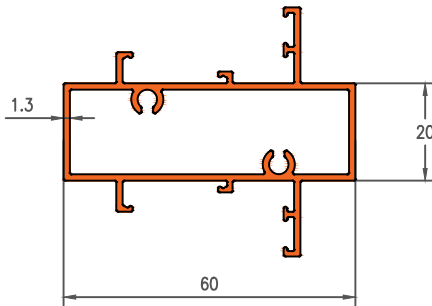

Die No.19449

1.019 Kg/m

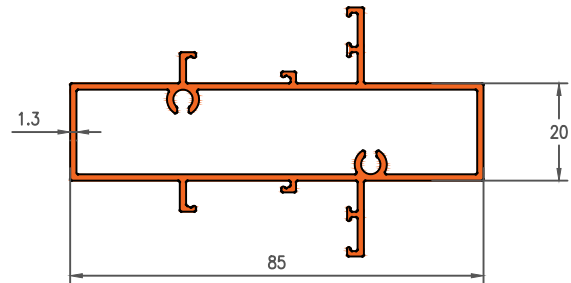

Die No.10090

0.891Kg/m

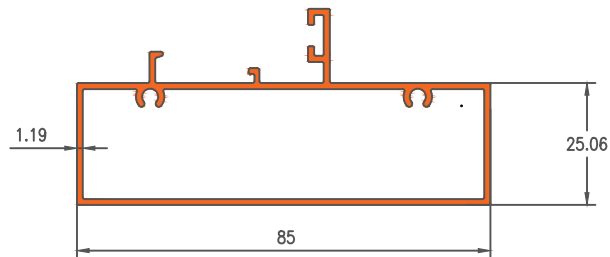

Die No.23142

1.059Kg/m

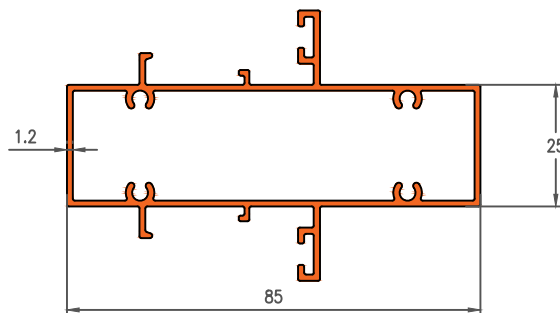

42 MM COMBO PIPE



Darshan Extrusions Pvt. Ltd.

Die No.16089

1.004Kg/m

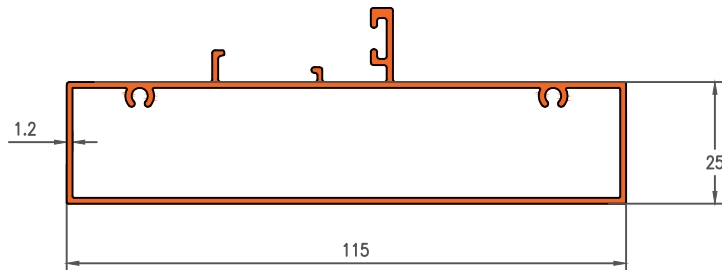

Die No.19724

1.096Kg/m

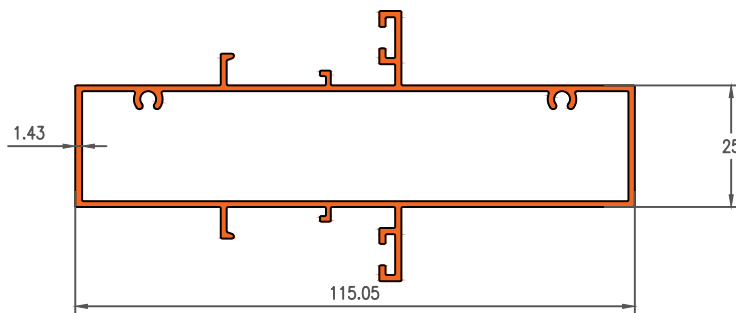

Die No.1383

0.268Kg/m

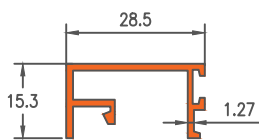

42 MM COMBO PIPE



Darshan Extrusions Pvt. Ltd.

Die No.16246

1.854 Kg/m

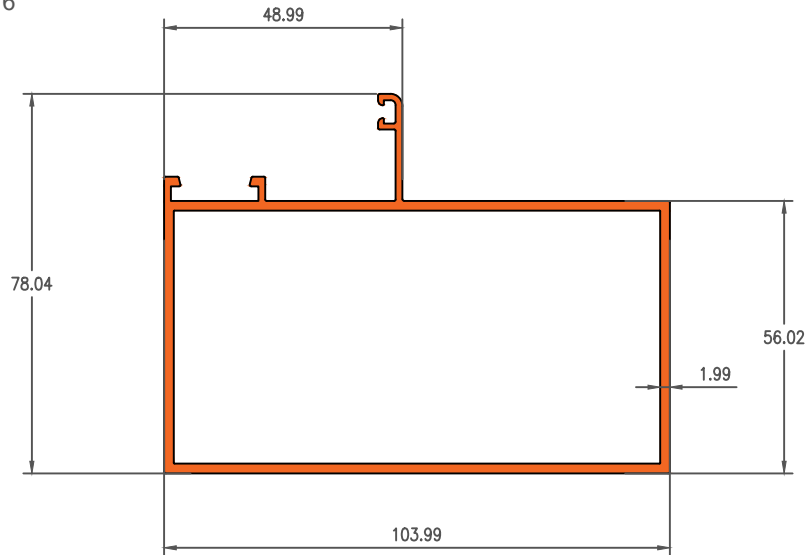

Die No.16043

1.797 Kg/m

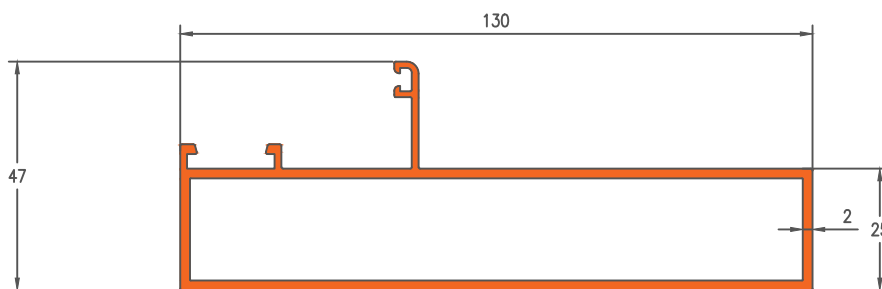

Die No.16041

1.249 Kg/m

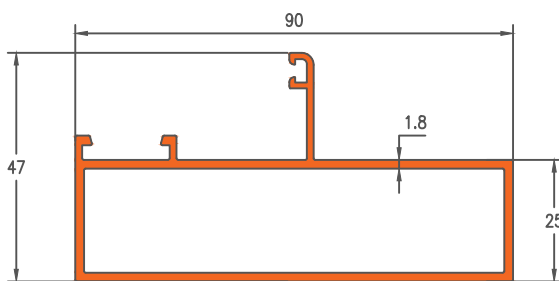

Die No.16042

1.416 Kg/m

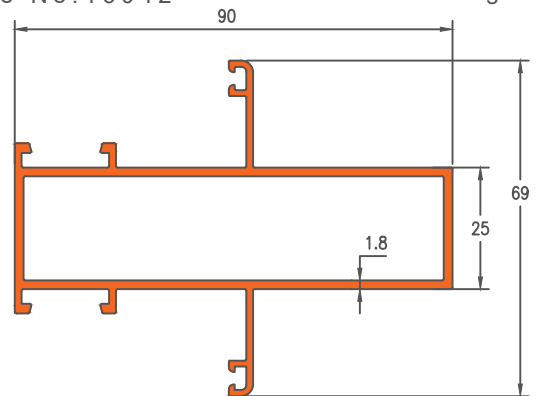

49 MM SERIES



Darshan Extrusions Pvt. Ltd.

Die No.16258

0.221Kg/m

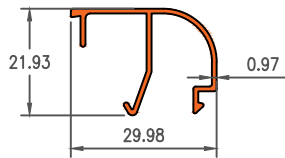

Die No.19357

0.209Kg/m

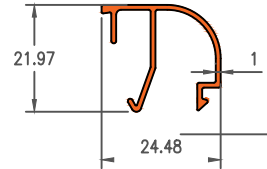

Die No.19358

0.180Kg/m

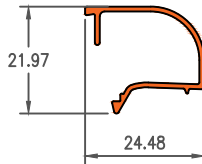

49 MM SERIES



Darshan Extrusions Pvt. Ltd.

Die No.1304

0.194 Kg/m

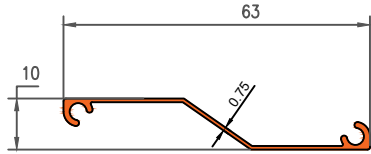

Die No.1374

0.358 Kg/m

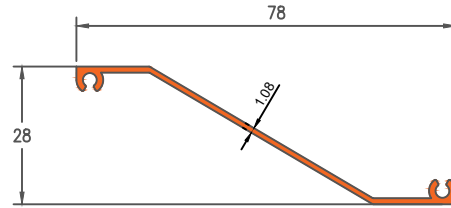

Die No. 16210

0.664 Kg/m

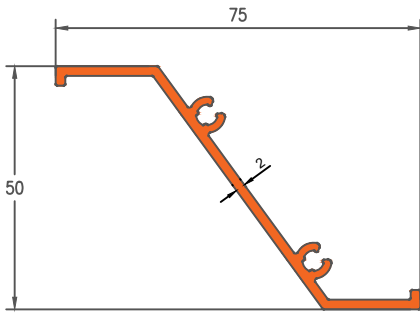

Die No. 1449

0.492 Kg/m

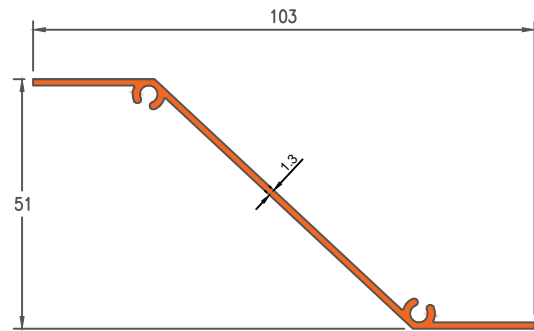

Die No. 19611

0.706 Kg/m

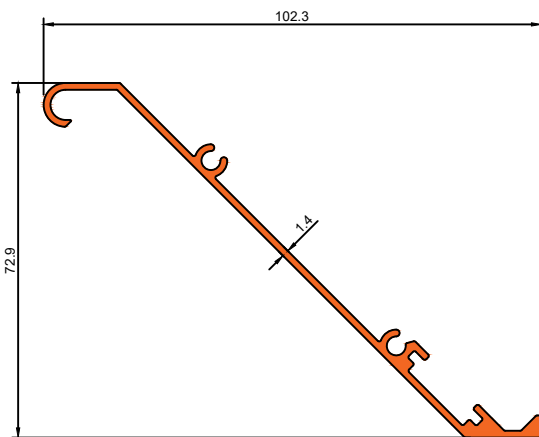

Die No. 20034

0.564 Kg/m

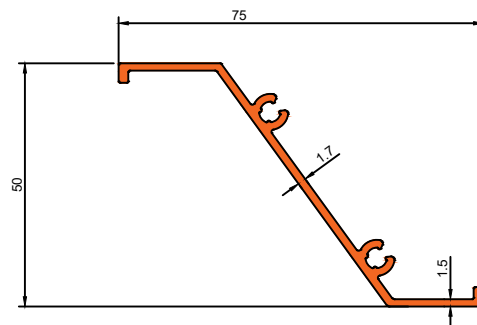

LOUVERS SECTION



Darshan Extrusions Pvt. Ltd.

Die No. 1470

0.981 Kg/m

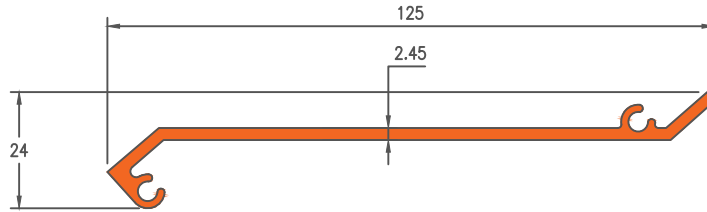

Die No. 28103

0.808 Kg/m

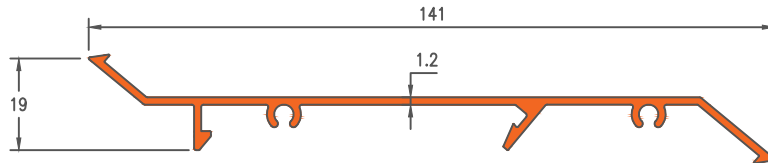

Die No. 16215

0.725 Kg/m

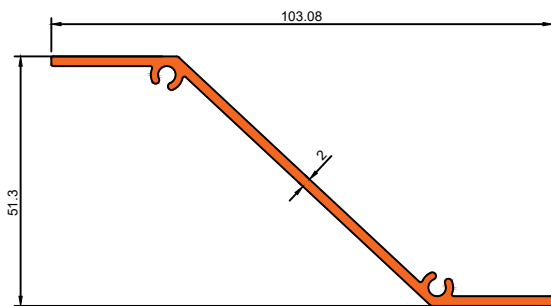

Die No. 28104

1.246 Kg/m

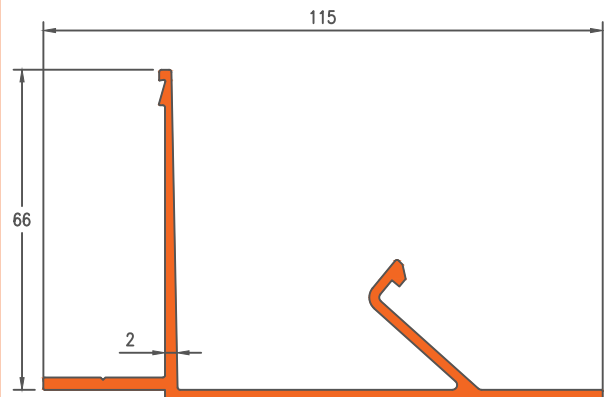

Die No. 16576

0.752 Kg/m

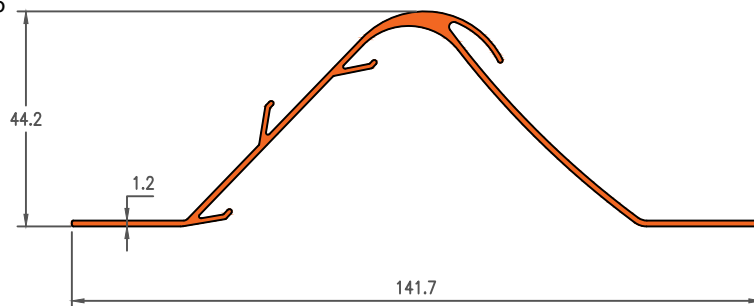

LOUVERS SECTION



Darshan Extrusions Pvt. Ltd.

Die No. 19022

0.410 Kg/m

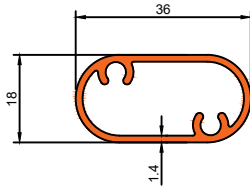

Die No. 16201

0.545 Kg/m

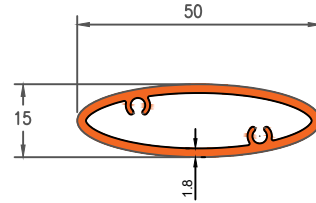

Die No. 1338

0.578 Kg/m

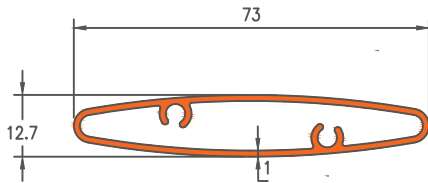

Die No. 1334

0.584 Kg/m

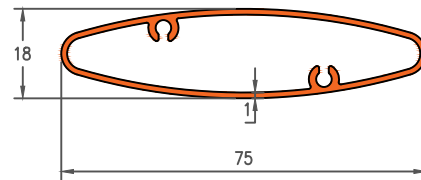

Die No. 16202

0.916 Kg/m

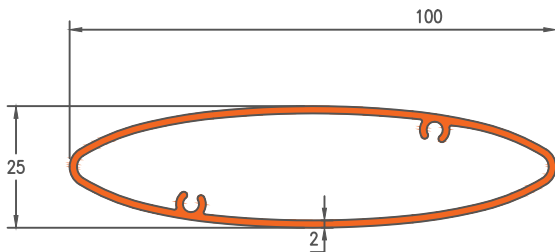

Die No. 16114

0.889 Kg/m

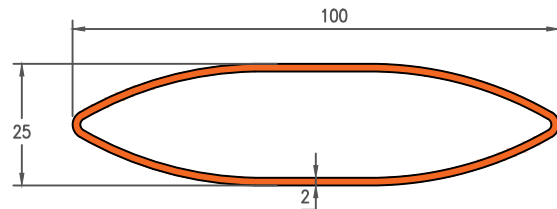

Die No. 5497

0.583 Kg/m

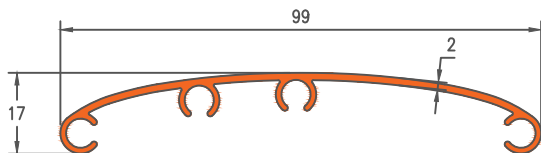

LOUVERS SECTION



Darshan Extrusions Pvt. Ltd.

Die No. 19121

1.297 Kg/m

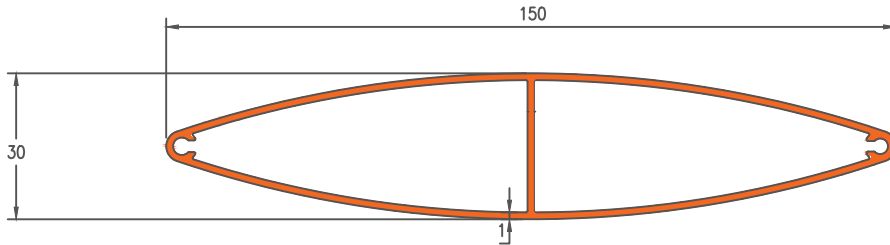

Die No. 19612

2.570 Kg/m

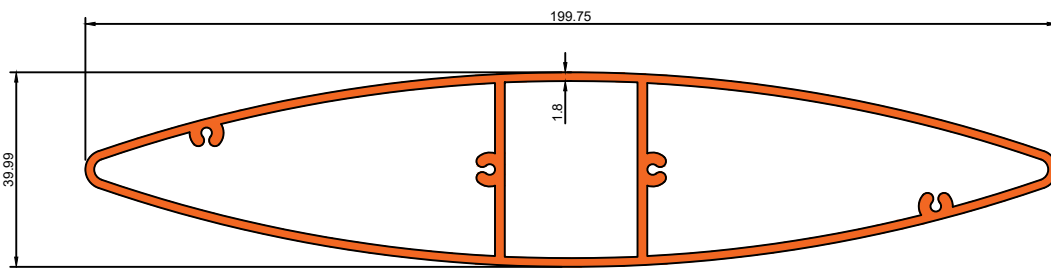

Die No. 16034

0.738 Kg/m

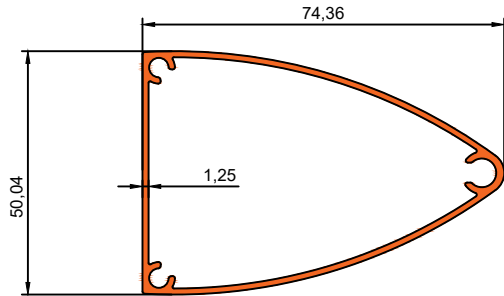

Die No. 1209

0.977 Kg/m

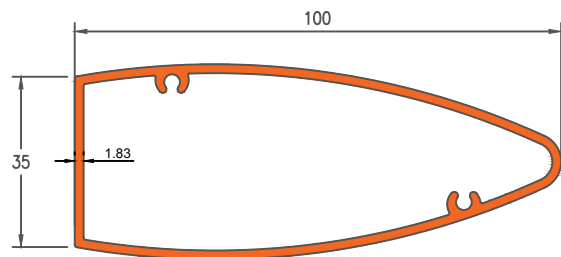

Die No. 16093

1.257 Kg/m

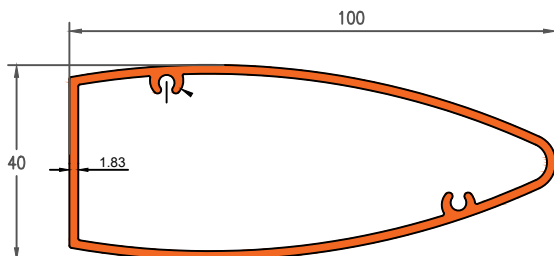

LOUVERS SECTION



Darshan Extrusions Pvt. Ltd.

Die No. 28160

1.118 Kg/m

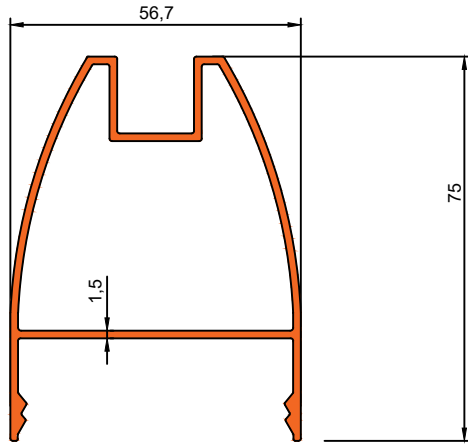

Die No. 19977

0.310 Kg/m

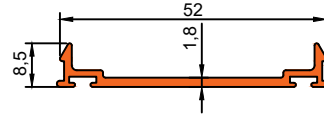

Die No. 16203

0.598 Kg/m

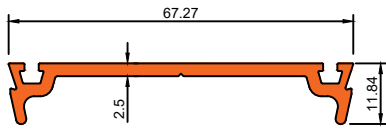

Die No. 16204

1.927 Kg/m

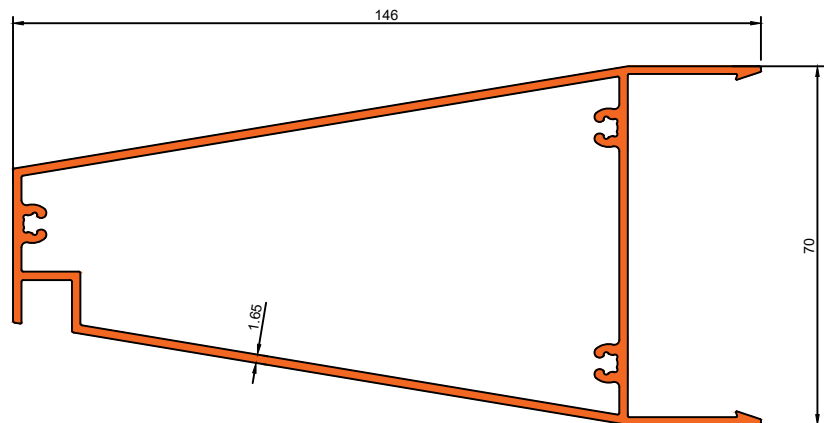

Die No. 16213

2.383 Kg/m

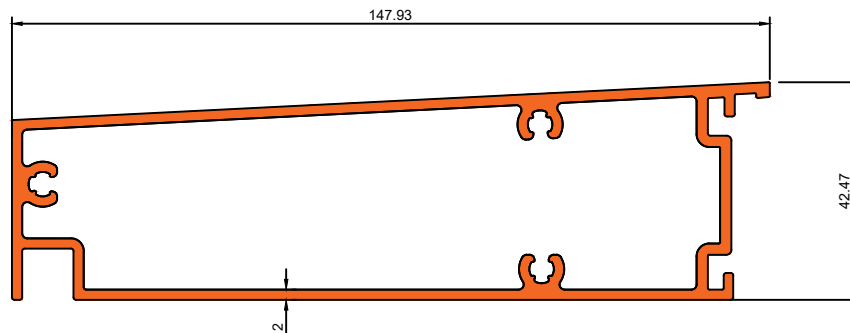

BULL NOSE



Darshan Extrusions Pvt. Ltd.

Die No. 19435

0.872Kg/m

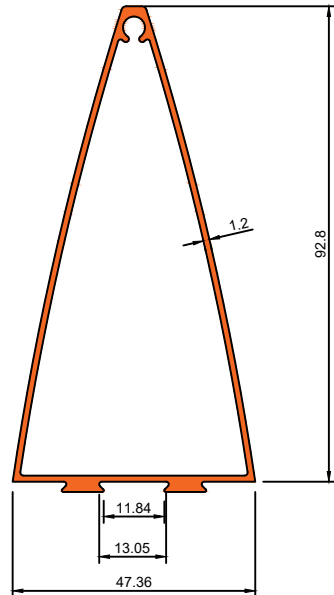

Die No. 19436

1.096Kg/m

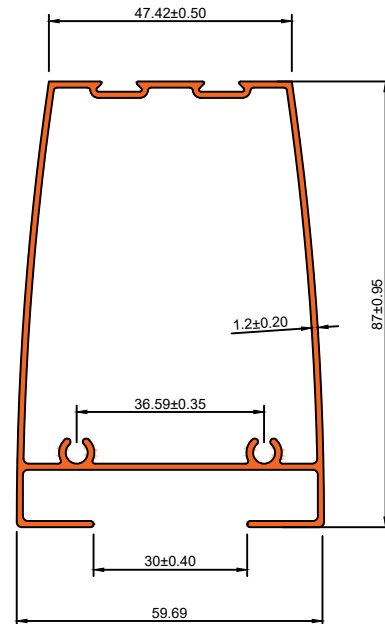

Die No. 16212

2.758Kg/m

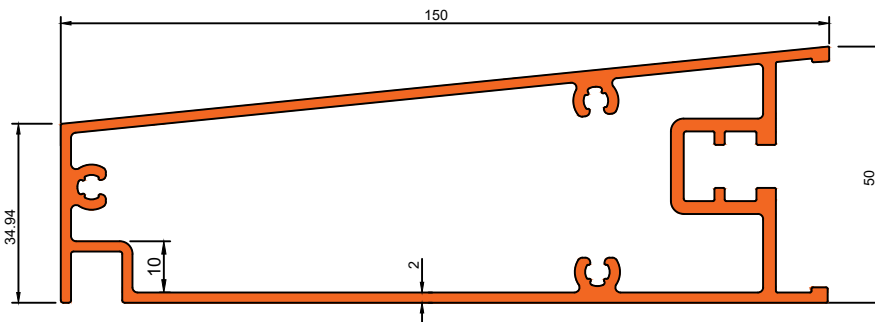

Die No. 19615

0.693Kg/m

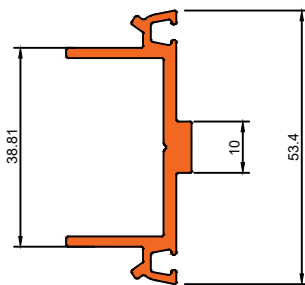

Die No. 19923

0.693Kg/m

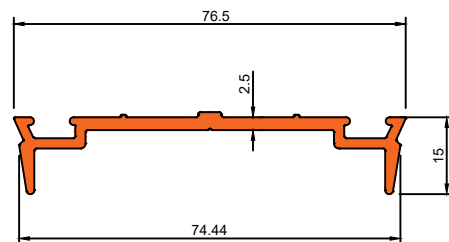

BULL NOSE



Darshan Extrusions Pvt. Ltd.

Die No. 19616

3.015Kg/m

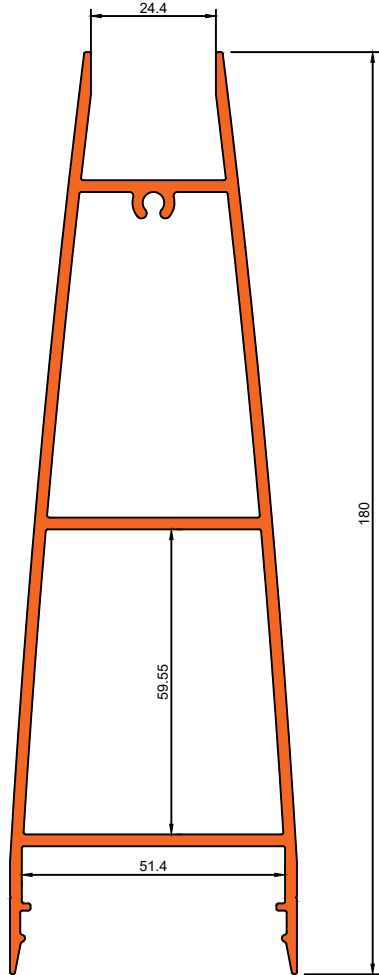

Die No. 16211

3.019Kg/m

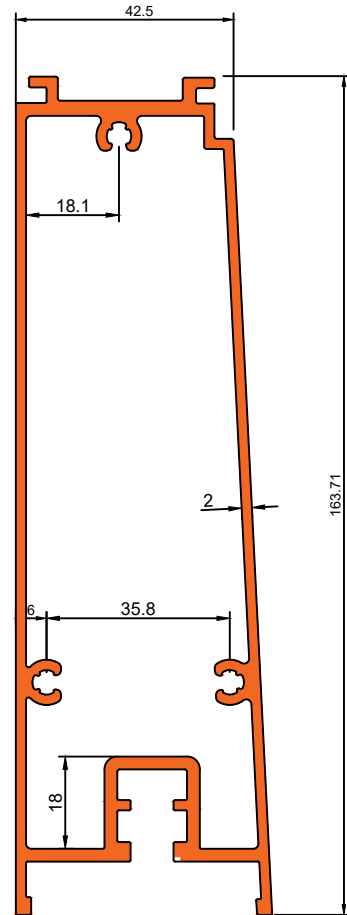

Die No. 19960

1.511 Kg/m

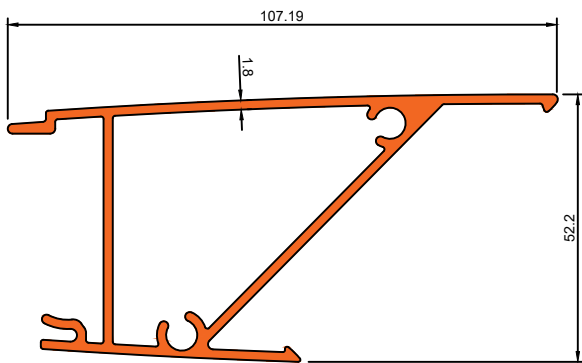

Die No. 19959

0.693 Kg/m

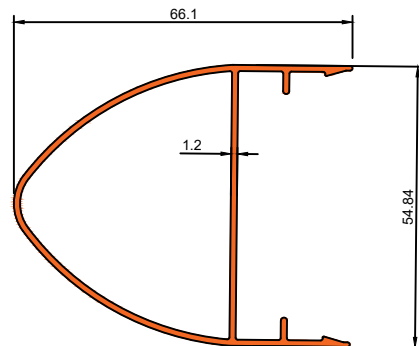

BULL NOSE



Die No. 19922

2.551 Kg/m

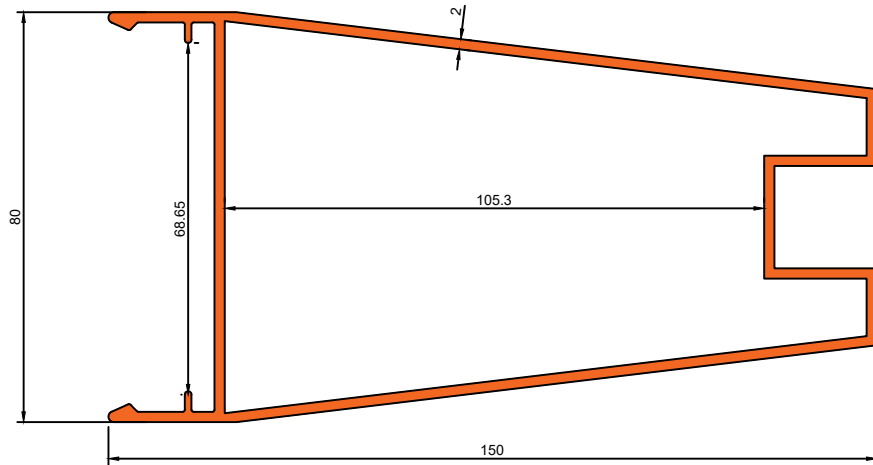

Die No. 19961

1.785 Kg/m

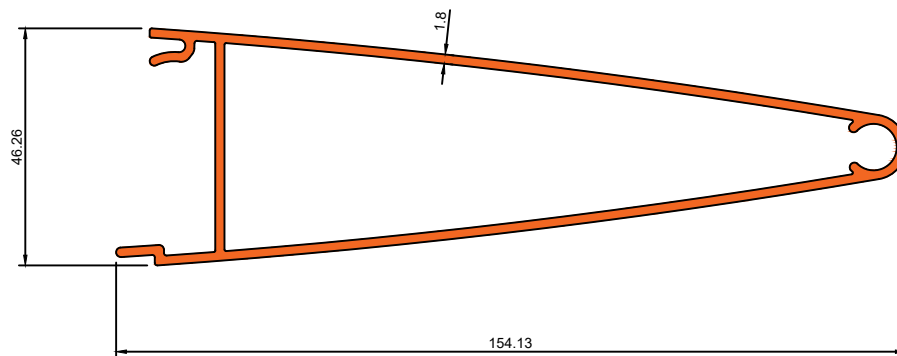

BULL NOSE



Darshan Extrusions Pvt. Ltd.

Die No.19402

1.461KG/M

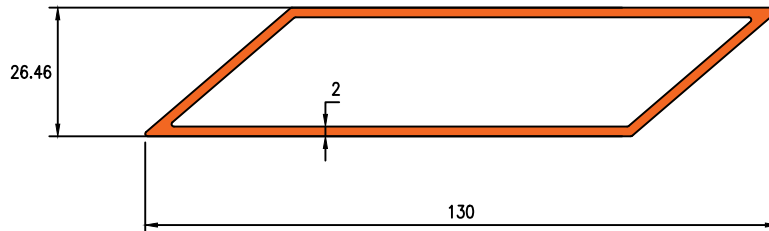

Die No.16115

0.295KG/M

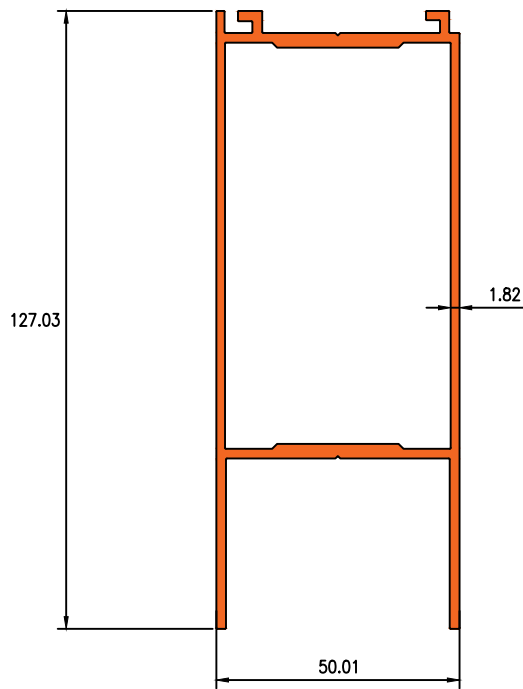

Die No.16117

2.443KG/M

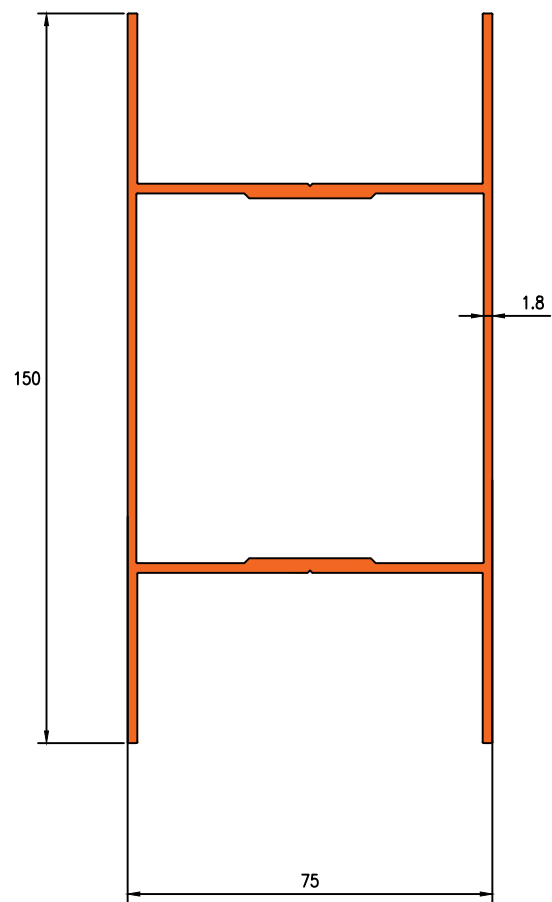

Die No.19184

0.552KG/M

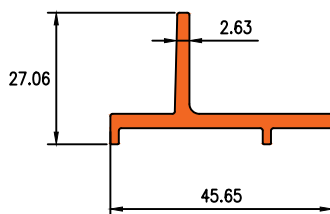

FACADE



Darshan Extrusions Pvt. Ltd.

Die No.19185

0.614KG/M

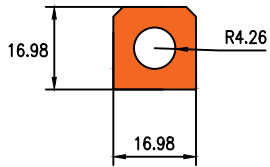

Die No.19206

0.557KG/M

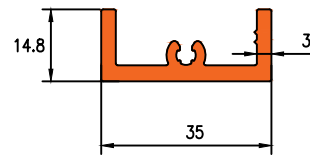

Die No.19185

1.185KG/M

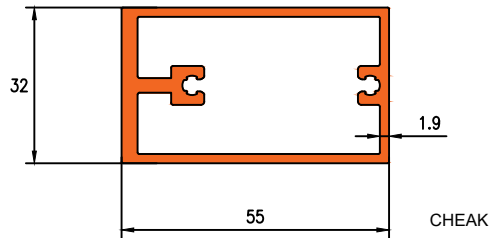

Die No.P71248

0.209KG/M

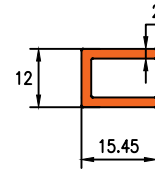

Die No.16249

4.33KG/M

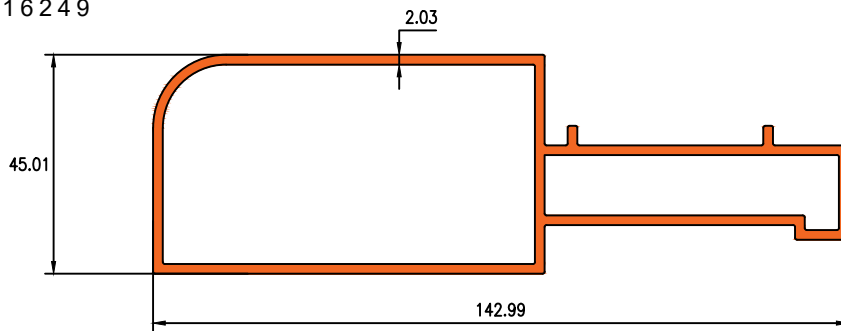

Die No.P71246

0.335KG/M

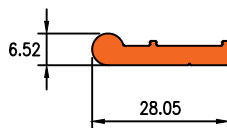

Die No.P71247

0.402KG/M

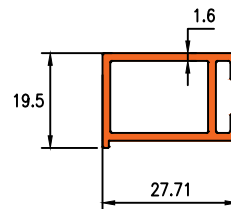

FACADE



Darshan Extrusions Pvt. Ltd.

Die No.P71249

0.386KG/M

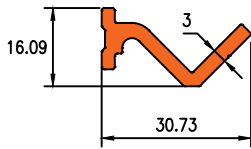

Die No.19201

1.494KG/M

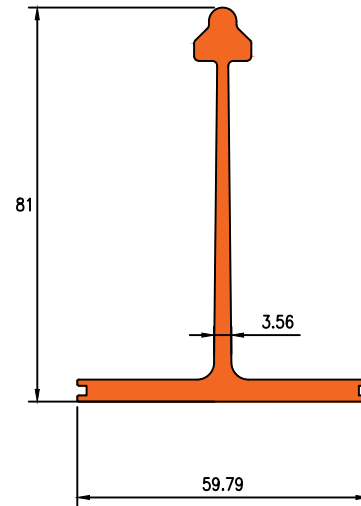

Die No.27019

0.296KG/M

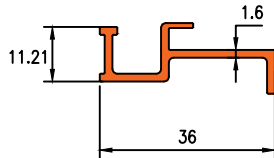

Die No.19186

0.465KG/M

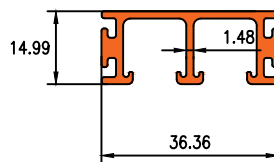

Die No.19187

0.431KG/M

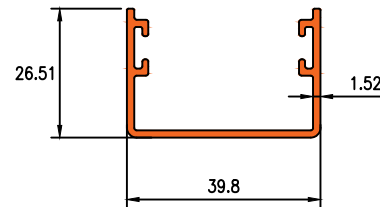

Die No.19188

0.328KG/M

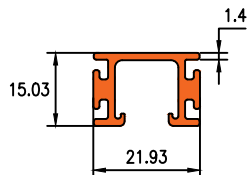

Die No.19189

0.379KG/M

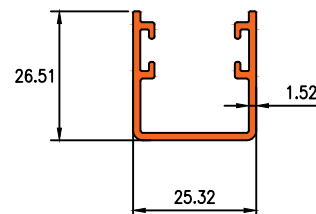

FACADE



Darshan Extrusions Pvt. Ltd.

Die No.21062

1.245KG/M

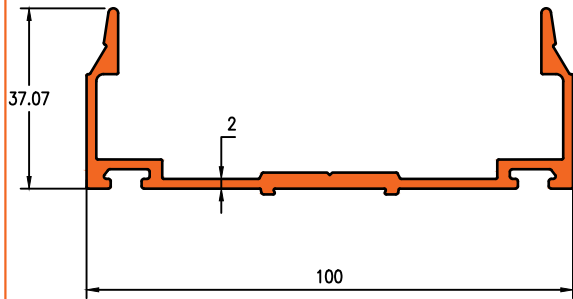

Die No.21063

2.663KG/M

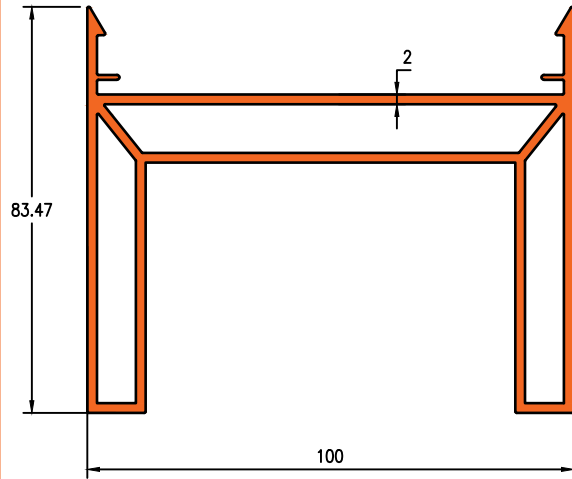

Die No.21064

2.203KG/M

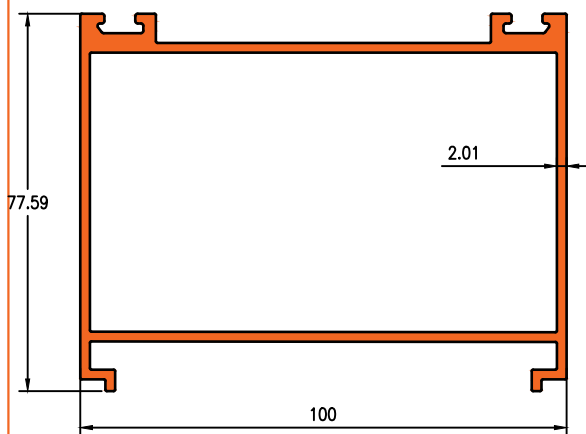

Die No.21065

1.559KG/M

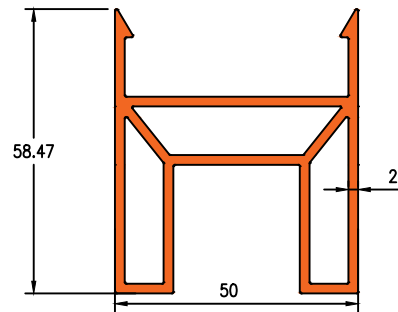

Die No.21066

0.750KG/M

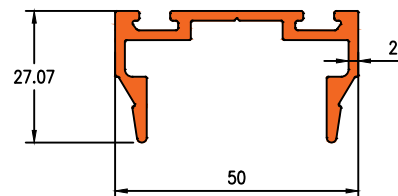

FACADE



Darshan Extrusions Pvt. Ltd.

Die No.21062

1.245KG/M

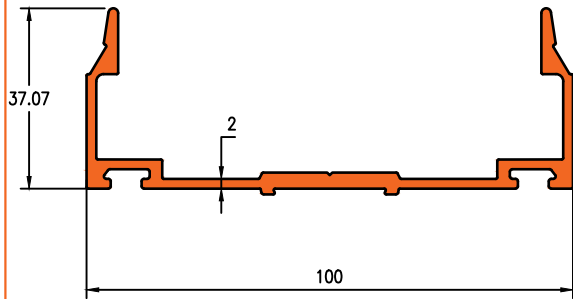

Die No.21063

2.663KG/M

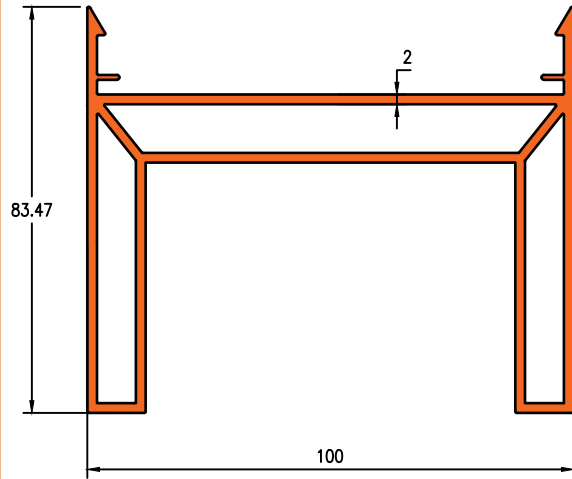

Die No.21064

2.203KG/M

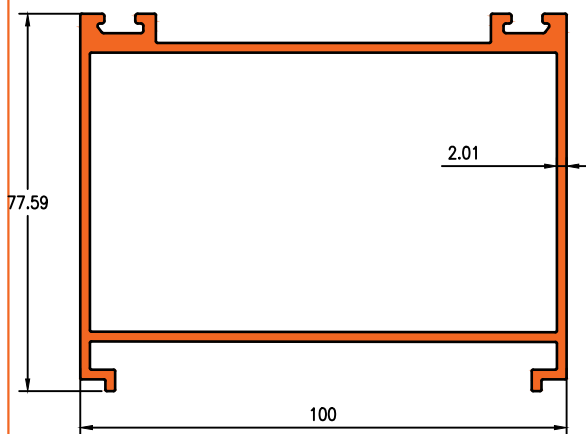

Die No.21065

1.559KG/M

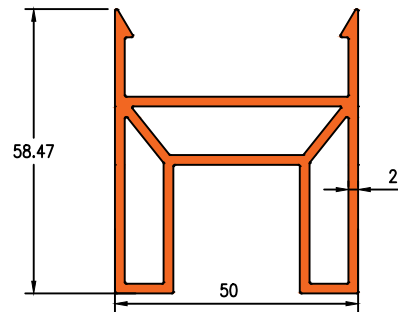

Die No.21066

0.750KG/M

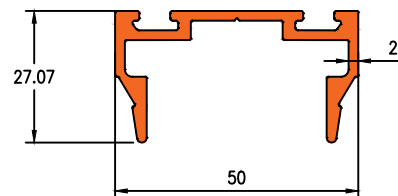

FACADE



Die No.21067

1.151 KG/M

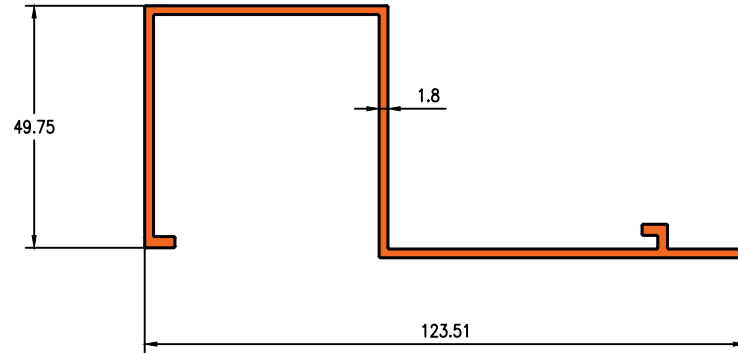

Die No.21068

1.394 KG/M

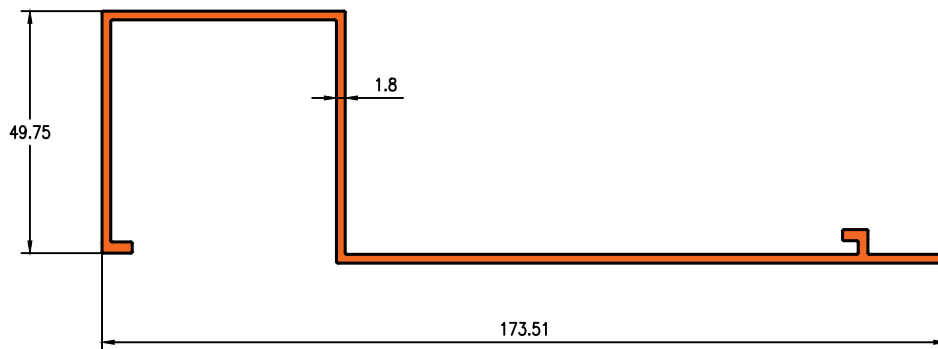



Die No. 16069

1.695 Kg/m

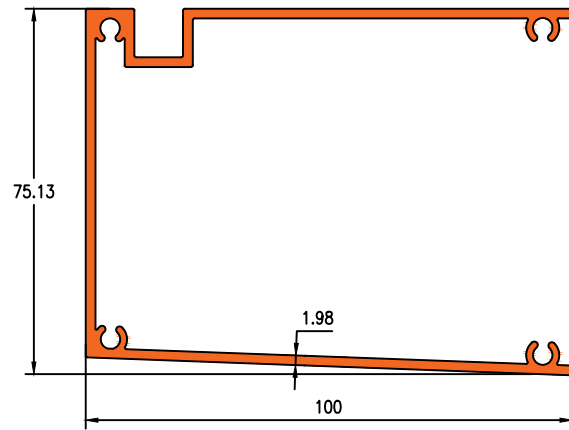

Die No. 28149

1.237 Kg/m

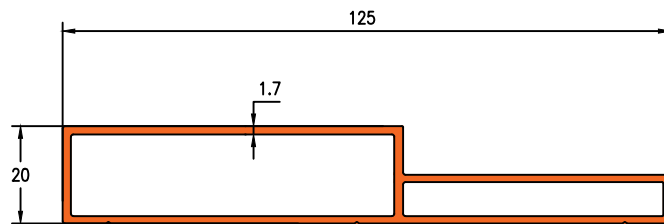

Die No. 28156

1.148 Kg/m

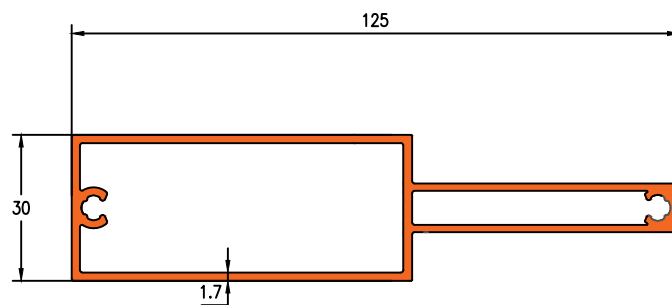



Darshan Extrusions Pvt. Ltd.

Die No. 10006

0.414Kg/m

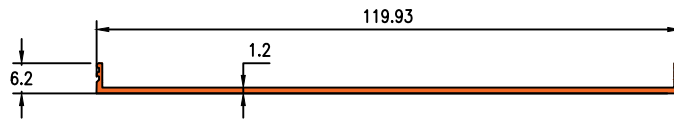

Die No. 10004

0.063Kg/m

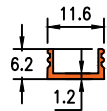

Die No. 10005

0.349Kg/m

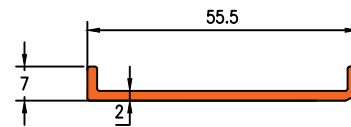

Die No. 10002

0.892Kg/m

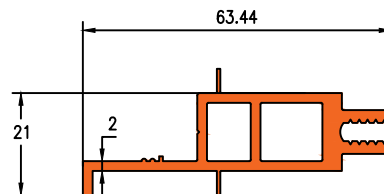

Die No. 10001

0.222Kg/m

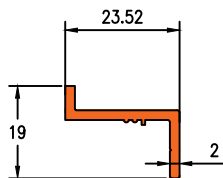

Die No. 10003

0.896Kg/m

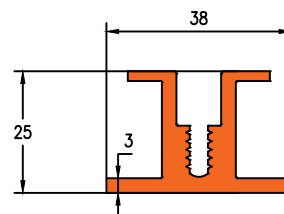

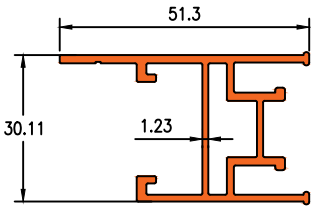
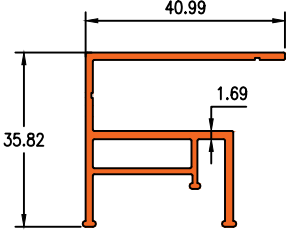
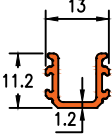
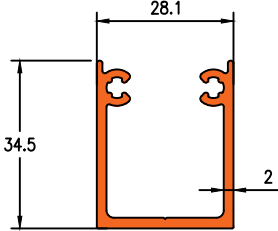
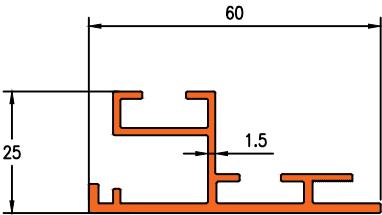

Darshan Extrusions Pvt. Ltd.

<p>Die No. 27018 0.714Kg/m</p> 	<p>Die No.27017 0.627Kg/m</p> 
<p>Die No. 7100 0.122Kg/m</p> 	<p>Die No. 7099 0.604Kg/m</p> 
<p>Die No. 10007 0.698Kg/m</p> 	





Darshan Extrusions Pvt. Ltd.

Die No.19433

0.734Kg/m

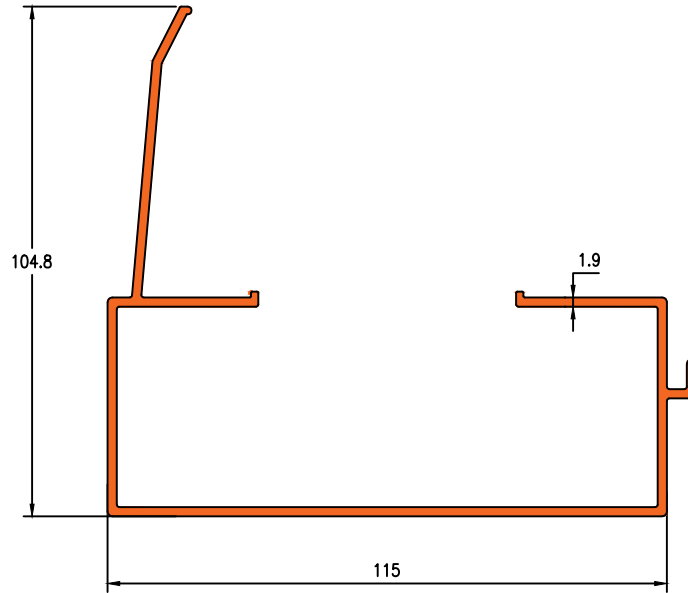

Die No.9138

1.638Kg/m

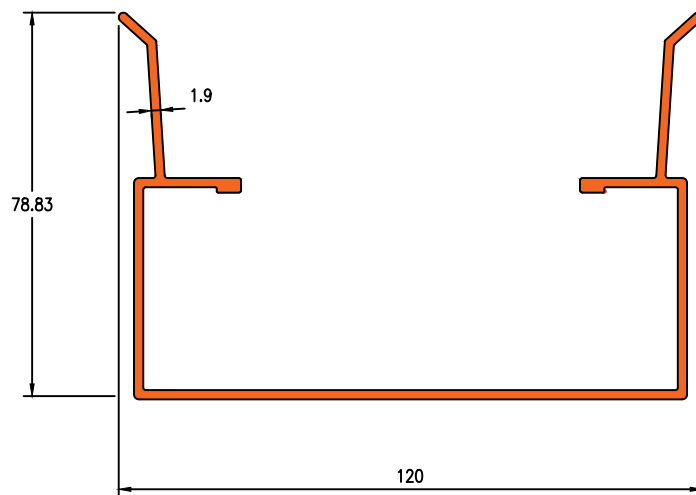



Die No.9145

2.013Kg/m

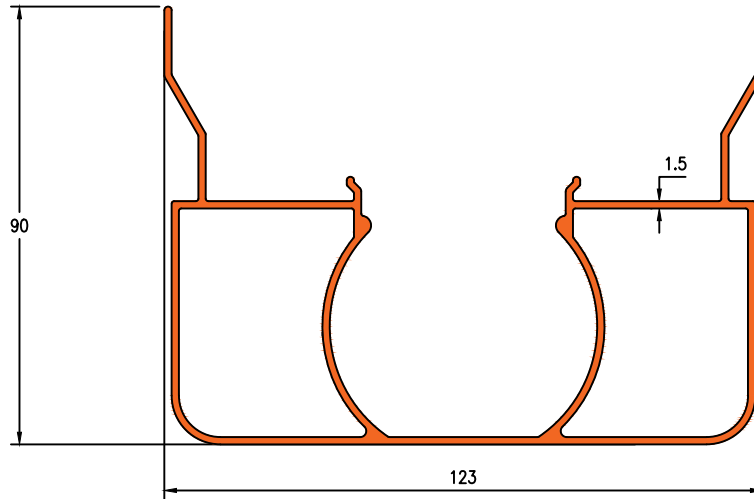

Die No.19719

0.760Kg/m

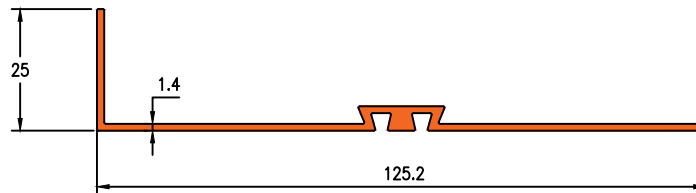

Die No.19720

0.786Kg/m

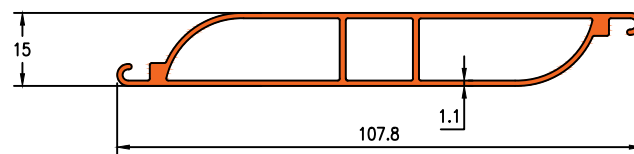



Darshan Extrusions Pvt. Ltd.

Die No.19721

0.910Kg/m

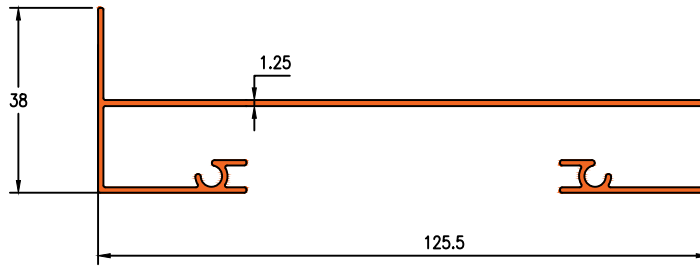

Die No.19483

1.460Kg/m

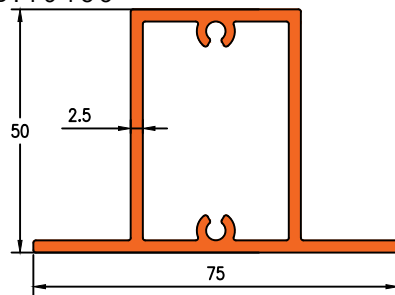

Die No.19479

0.712Kg/m

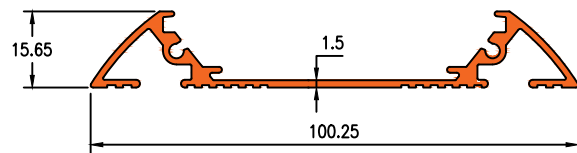

Die No.23003

1.328Kg/m

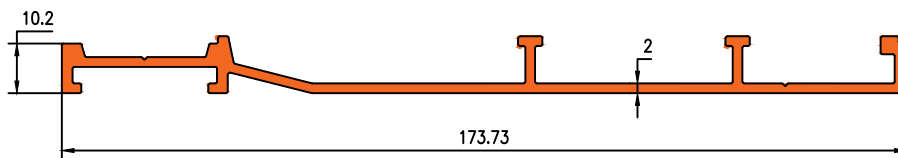

Die No.23004

2.330Kg/m

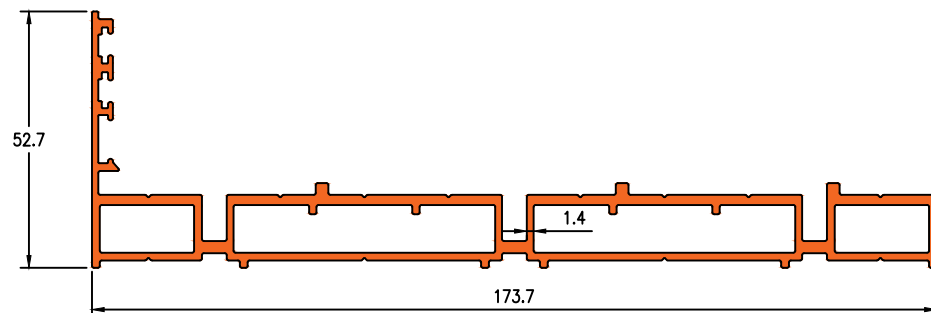



Darshan Extrusions Pvt. Ltd.

Die No.19655

2.776Kg/m

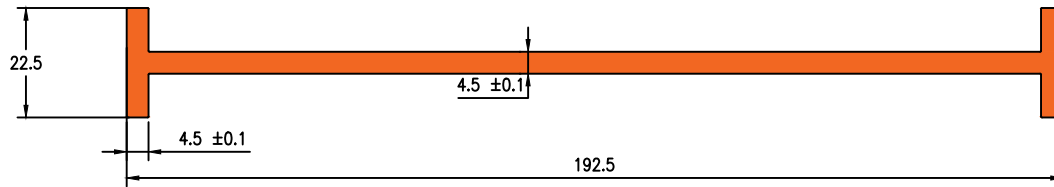

Die No.19654

1.368Kg/m

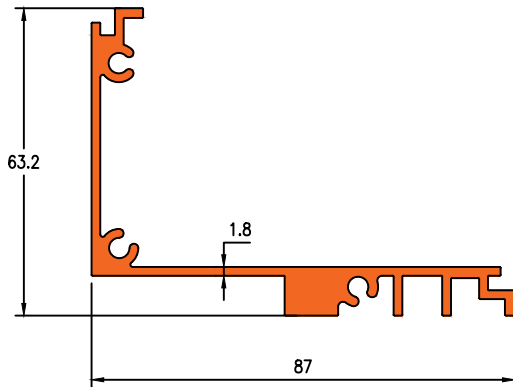

Die No.20037

1.501Kg/m

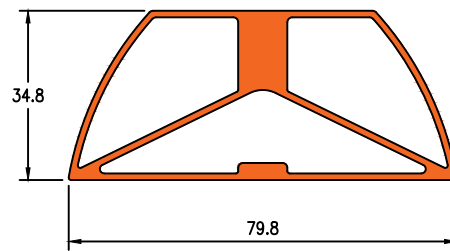

Die No.20049

0.091Kg/m

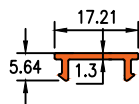

Die No.20050

0.144Kg/m

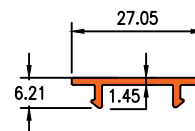



Darshan Extrusions Pvt. Ltd.

Die No.21070

0.572 Kg/m

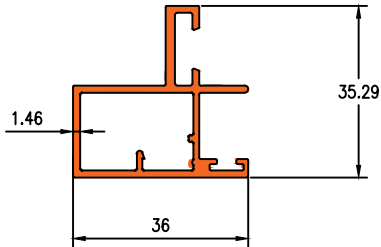

Die No.21071

0.590 Kg/m

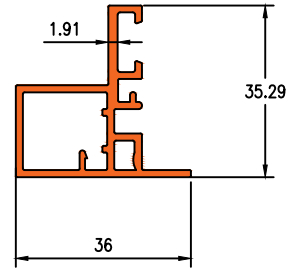

Die No.21072

0.457 Kg/m

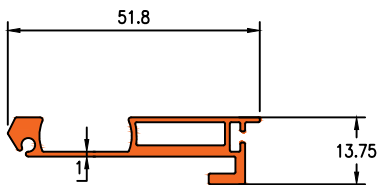

Die No.21073

0.414 Kg/m

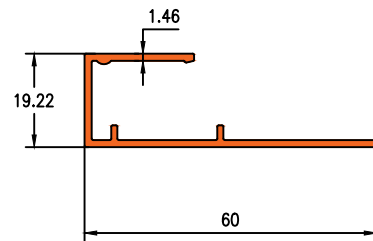

Die No.21102

0.599 Kg/m

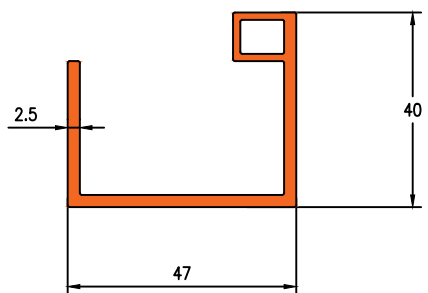
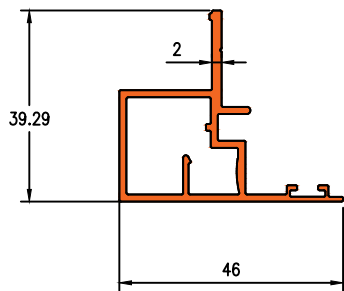

Die No.21104

0.124 Kg/m

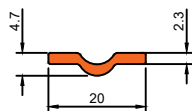



Die No.19981

1.639 Kg/m

