

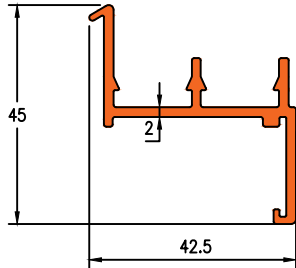

Darshan Extrusions Pvt. Ltd.

Die No.1243

0.620Kg/m



Die No.1222

0.579Kg/m

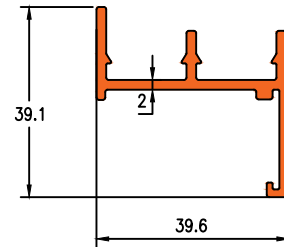

Die No.19142

4.932Kg/m

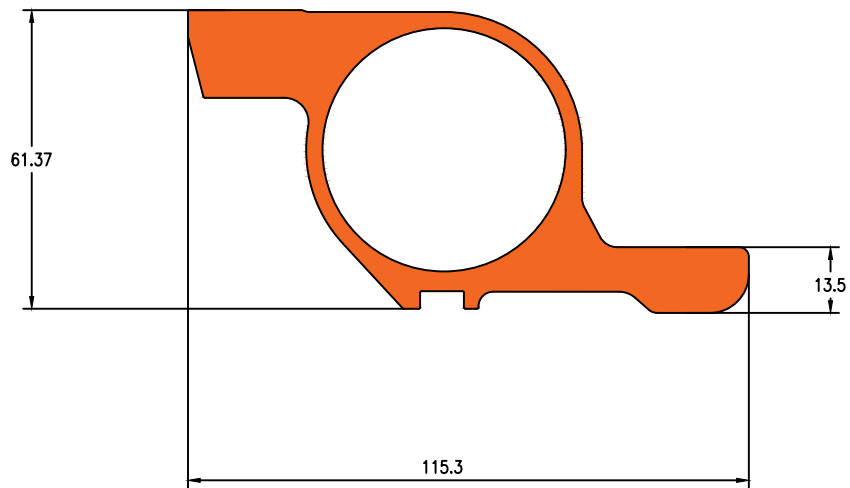

AUTOMOBILE



Darshan Extrusions Pvt. Ltd.

Die No.19501

5.237Kg/m

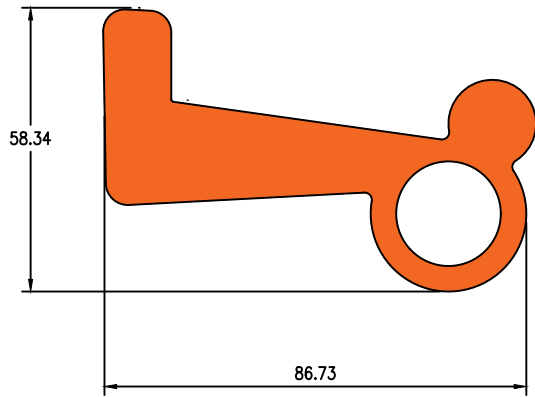

Die No.19502

3.219Kg/m

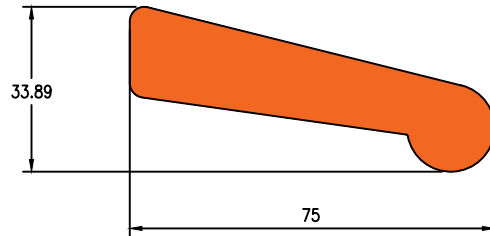

Die No.19547

4.558Kg/m

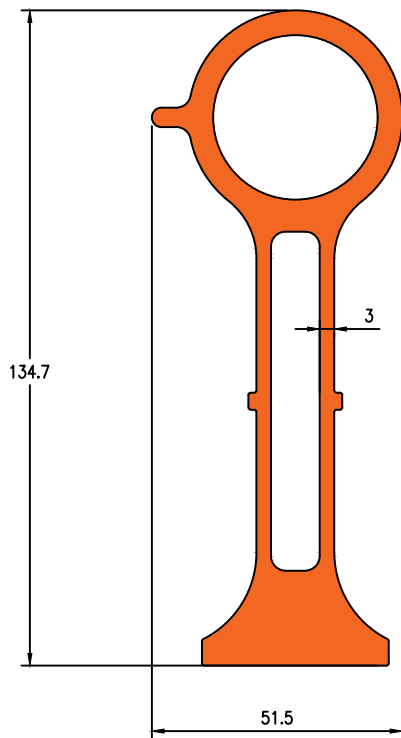

Die No.19546

7.431Kg/m

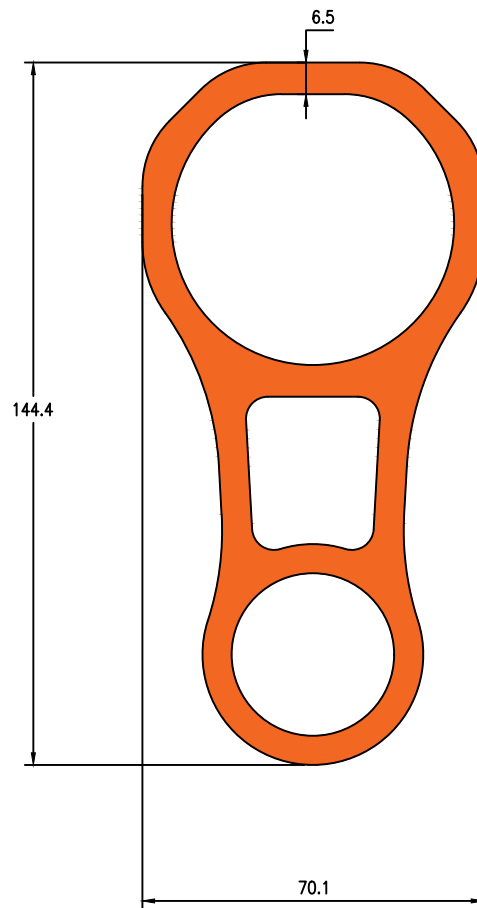

AUTOMOBILE



Darshan Extrusions Pvt. Ltd.

Die No.19548

4.190Kg/m

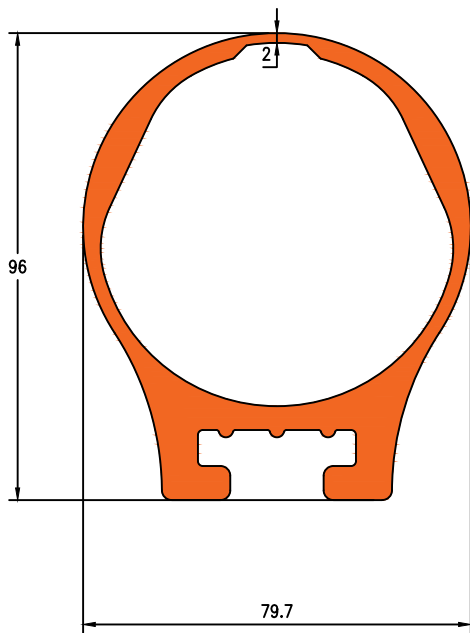

Die No.20744

5.707 Kg/m

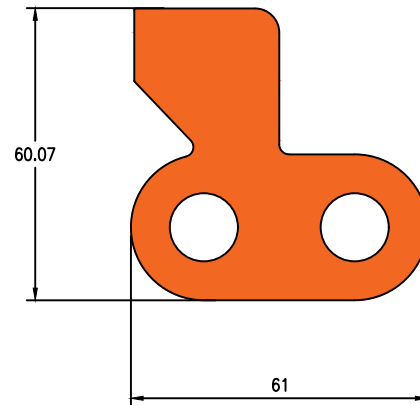

Die No.19143

8.140 Kg/m

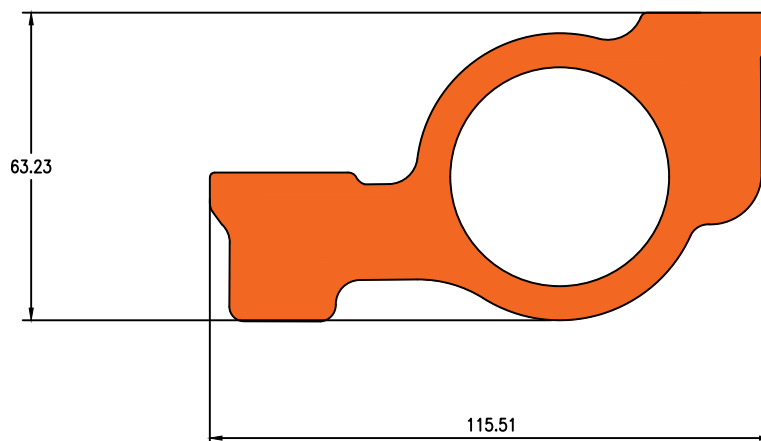

AUTOMOBILE



Die No.19144

8 . 260 Kg/m

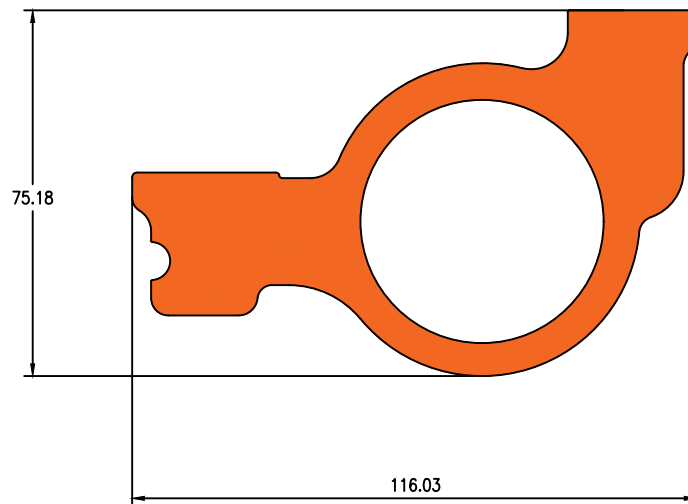

Die No.20741

7 . 538 Kg/m

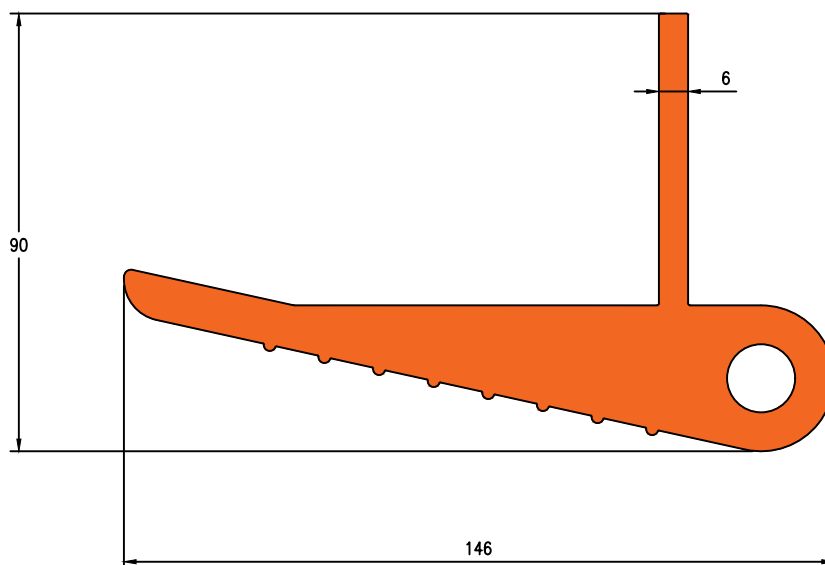

AUTOMOBILE



Die No.20743

3 . 70 Kg/m

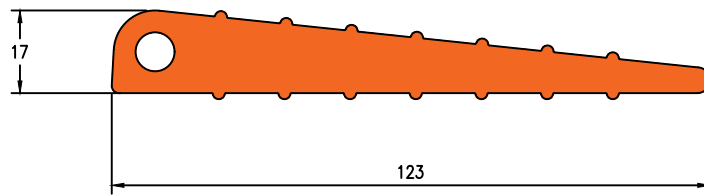

Die No.20740

6 . 024 Kg/m

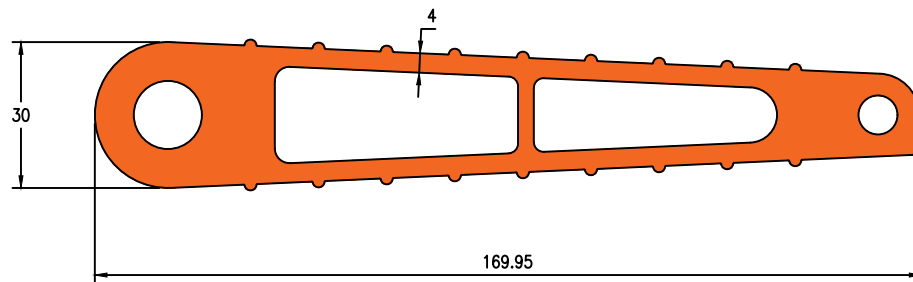

Die No.20742

4 . 253 Kg/m

