

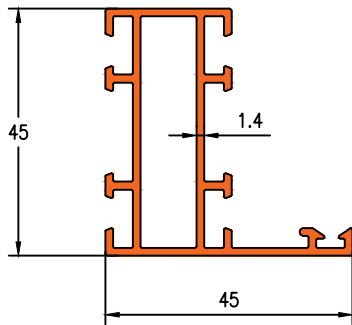

Die No. 5103

0.788KG/M



Die No. 5101

0.909KG/M

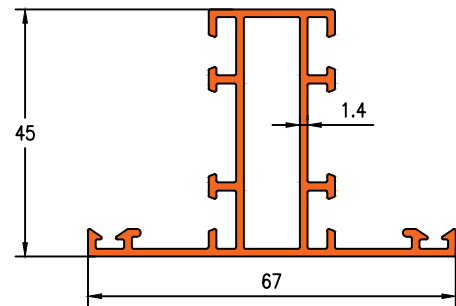

Die No. 5102

0.909KG/M

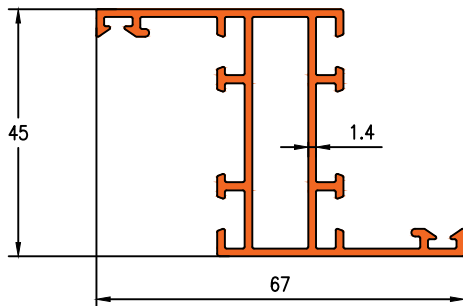

Die No. 5173

0.956KG/M

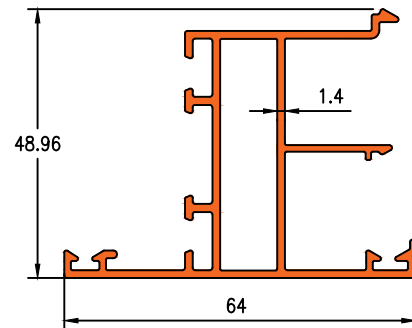

Die No. 5169

0.947KG/M

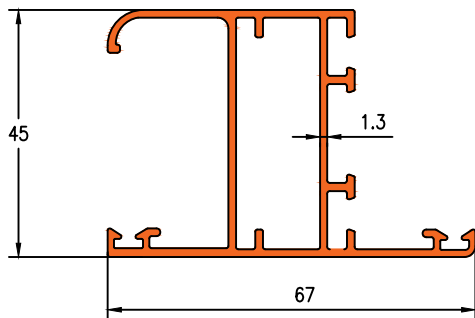

Die No. 5151

1.092KG/M

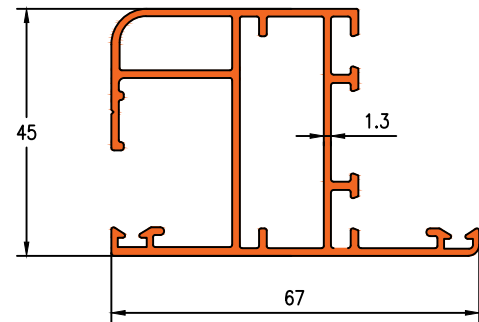

Die No. 5157

0.844KG/M

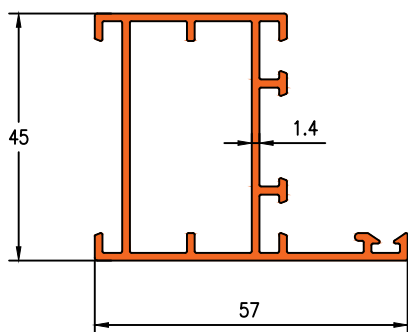

Die No. 5110

0.906KG/M

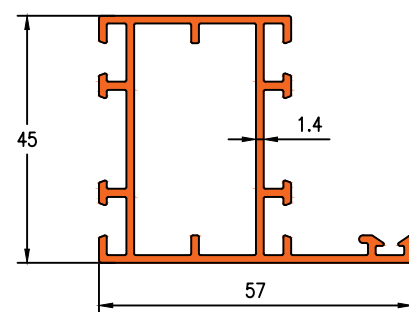



Darshan Extrusions Pvt. Ltd.

Die No.5109

1.137KG/M

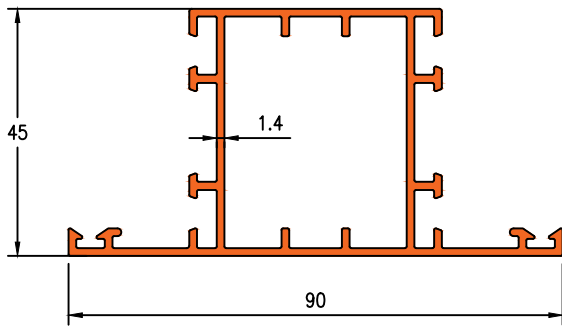

Die No.5108

1.137KG/M

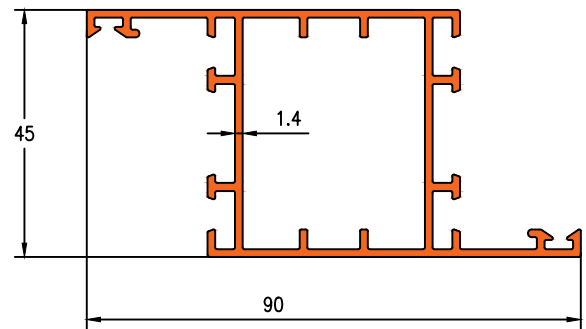

Die No.5367

0.581KG/M

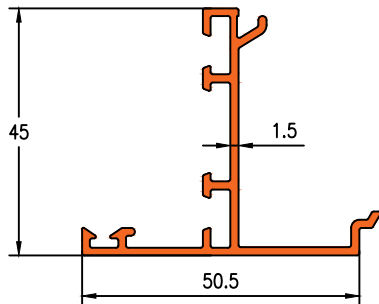

Die No.5170

0.956KG/M

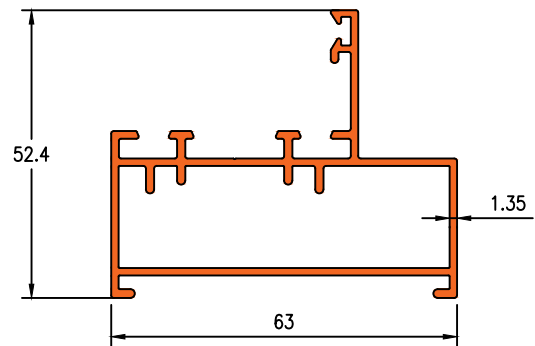

Die No.5137

1.612KG/M

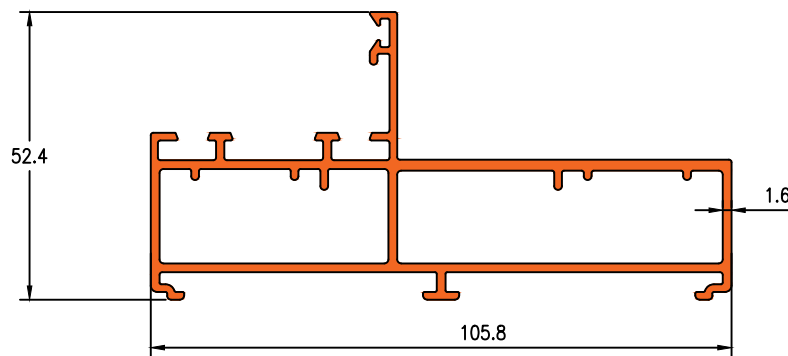

Die No.3820

1.920KG/M

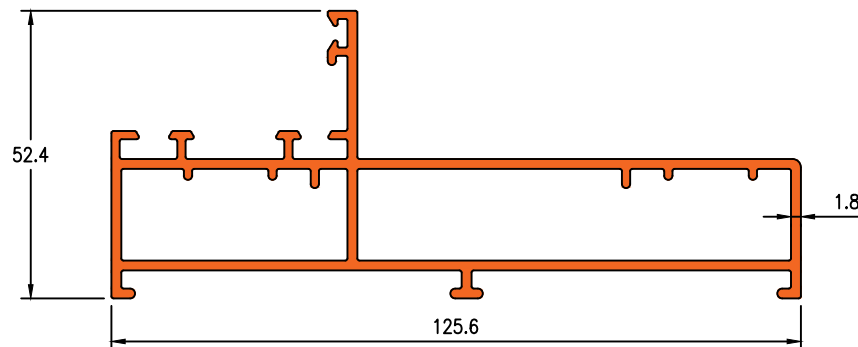



Die No.7870

2.283KG/M

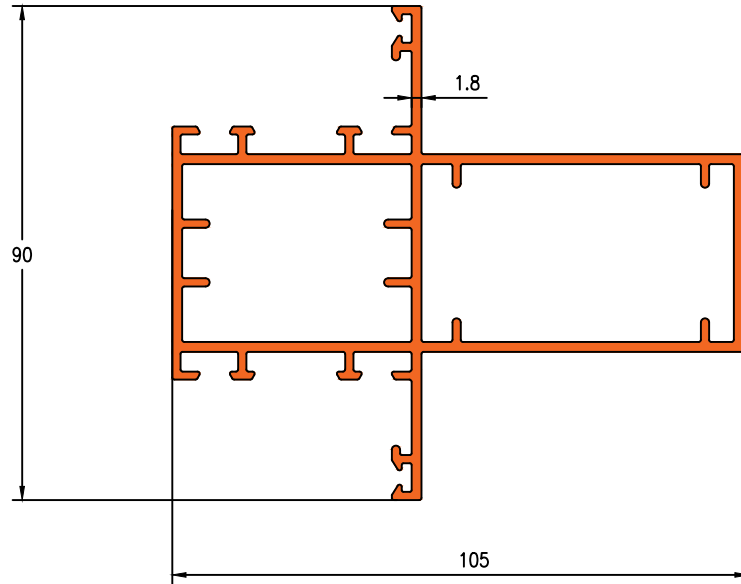

Die No.3819

2.528KG/M

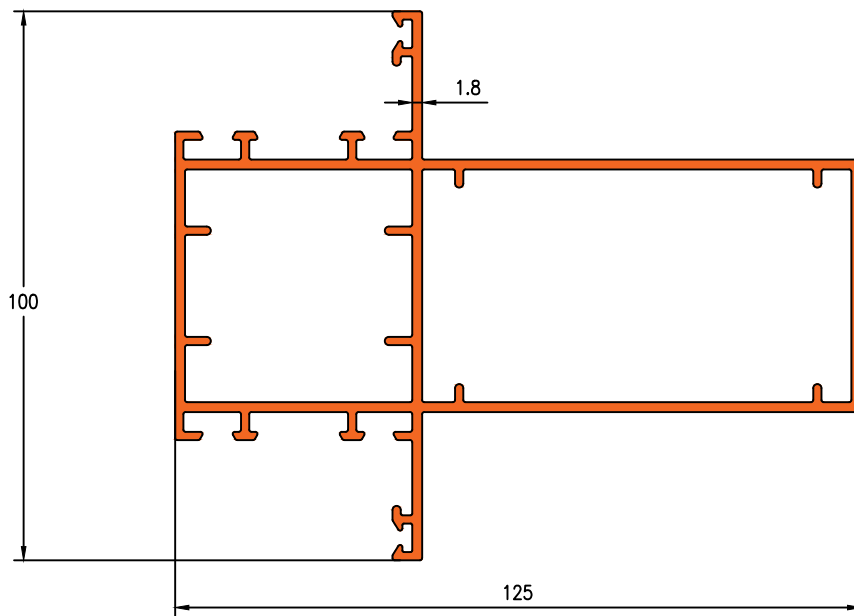



Darshan Extrusions Pvt. Ltd.

Die No.7868

2.271KG/M

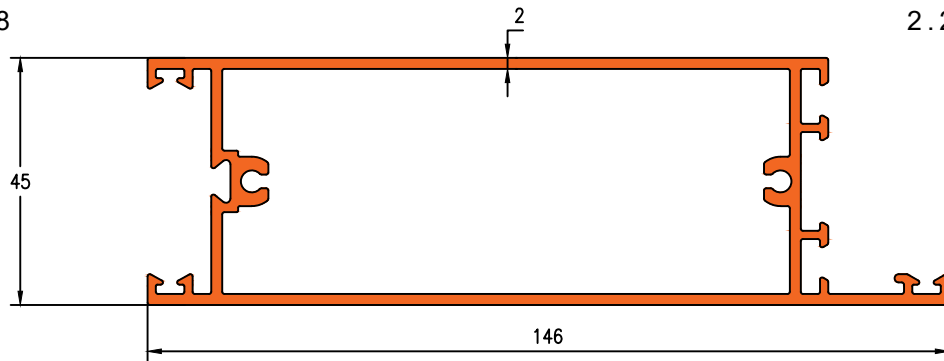

Die No.5185

0.279KG/M

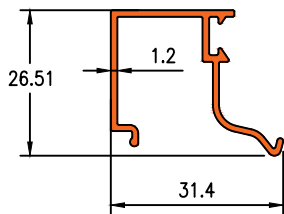

Die No.19643

0.275KG/M

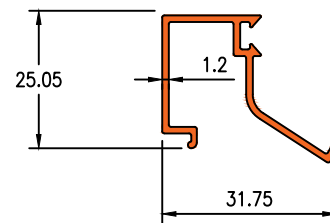

Die No.5150

0.268KG/M

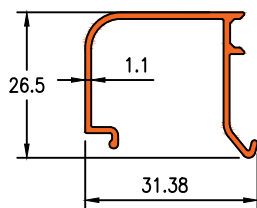

Die No.5149

0.246KG/M

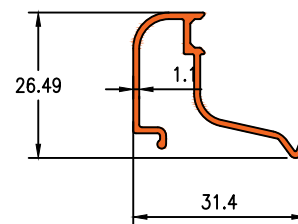

Die No.20113

0.253KG/M

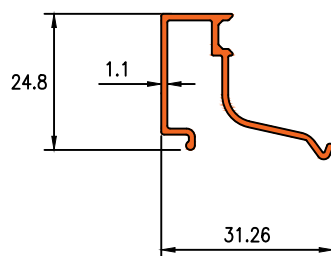



Darshan Extrusions Pvt. Ltd.

Die No.16100

1.033KG/M

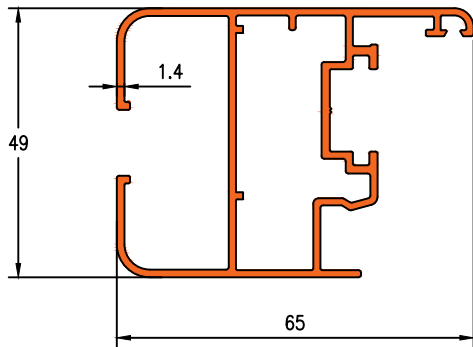

Die No.16101

1.003KG/M

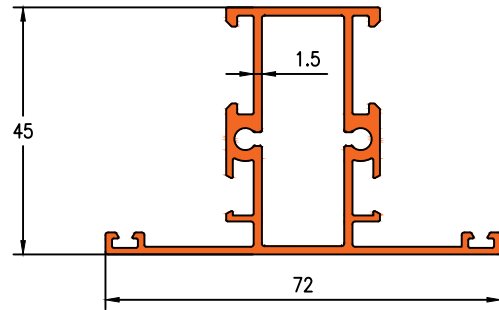

Die No.16102

0.612KG/M

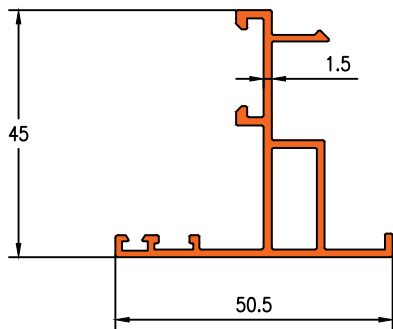

Die No.2854

0.578KG/M

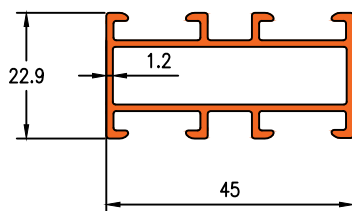

Die No.2853

0.866KG/M

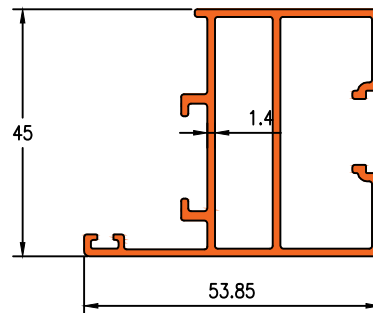

Die No.2856

0.203KG/M

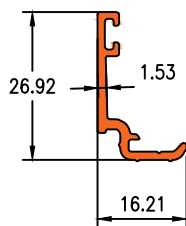

Die No.16099

0.208KG/M

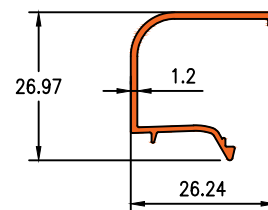



Die No.16096

0.434KG/M

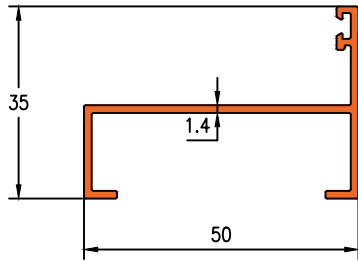

Die No.16097

0.781KG/M

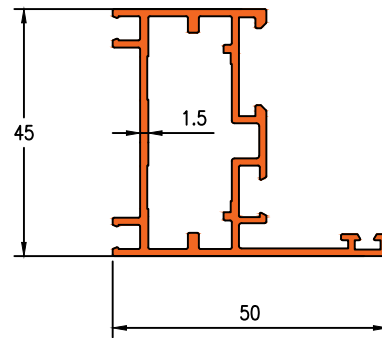

Die No.16098

0.260KG/M

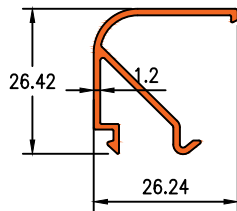

Die No.2855

0.288KG/M

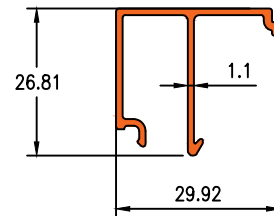

Die No.2852

0.590KG/M

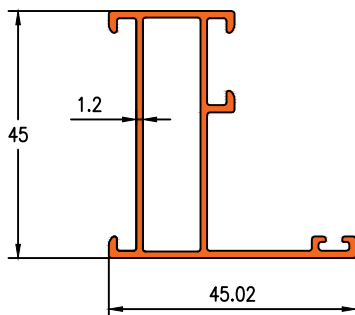



Darshan Extrusions Pvt. Ltd.

Die No.16056

0.962KG/M

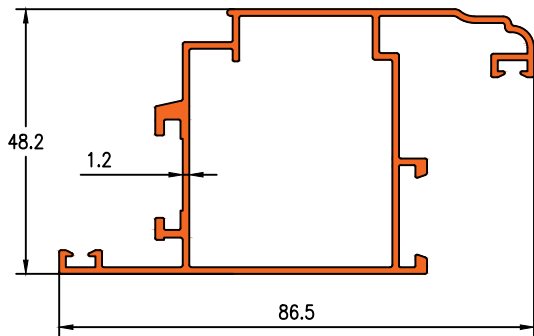

Die No.16058

0.702KG/M

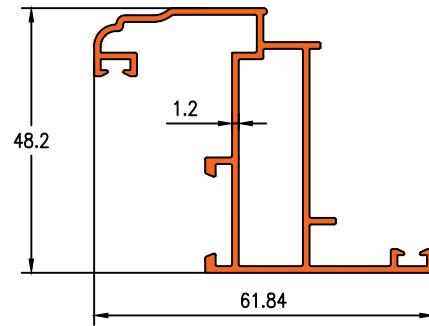

Die No.16057

0.958KG/M

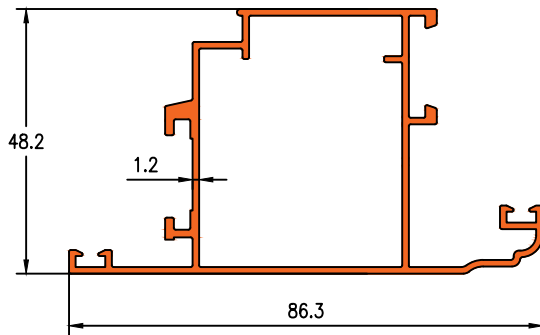

Die No.16059

0.768KG/M

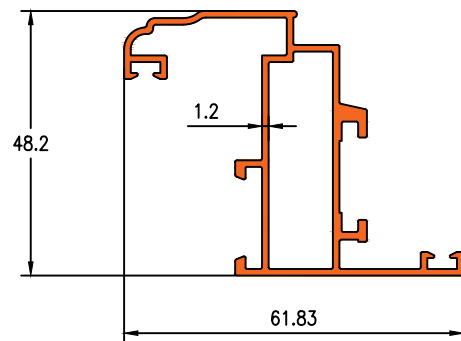

Die No.16061

0.778KG/M

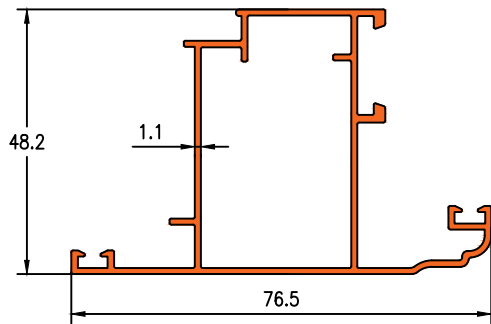

Die No.16060

0.792KG/M

