

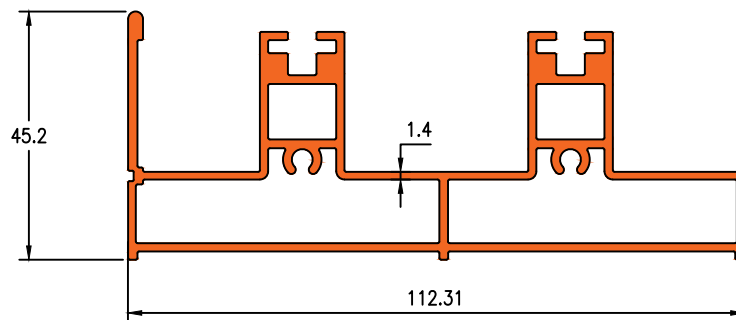

Die No.16604

2.015 KG/M



Die No.16613

1.696 KG/M

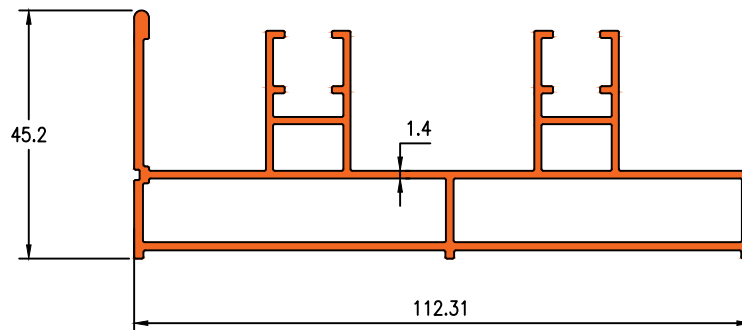

Die No.16605

1.787 KG/M

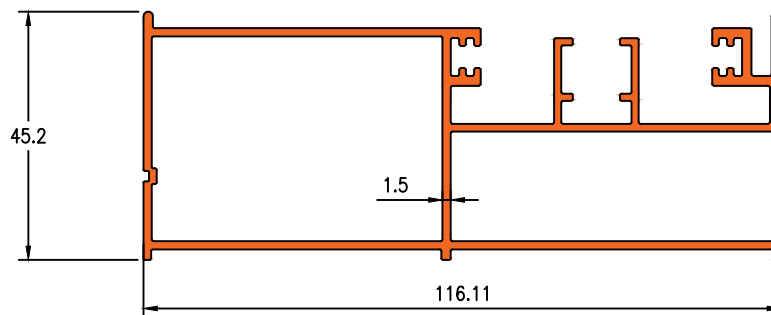

Die No.16617

2.585 KG/M

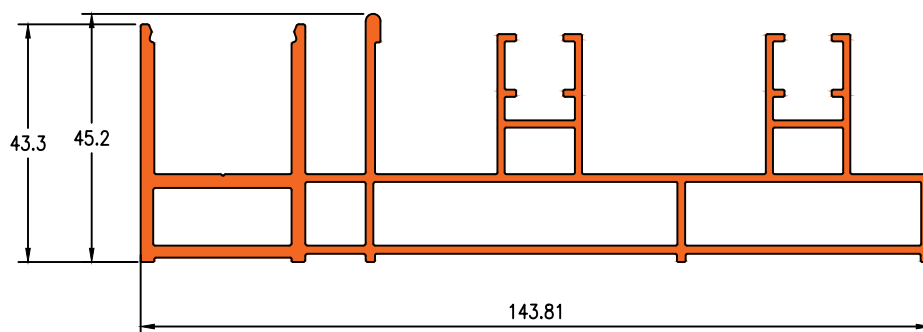



Die No.16618

2.821 KG/M

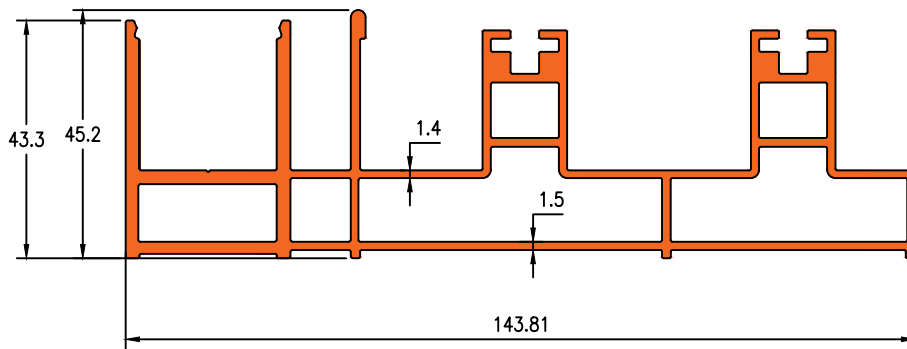

Die No. 16614

1.066KG/M

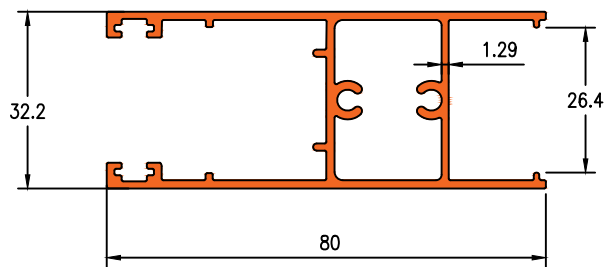

Die No. 16611

1.010KG/M

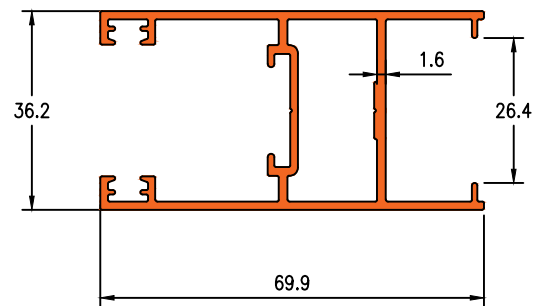

Die No. 16607

0.623KG/M

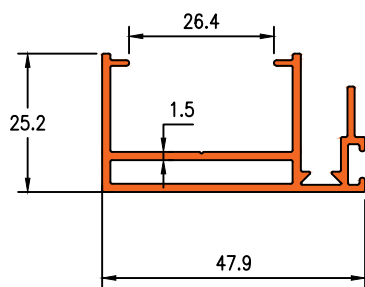

Die No. 16612

1.206 KG/M

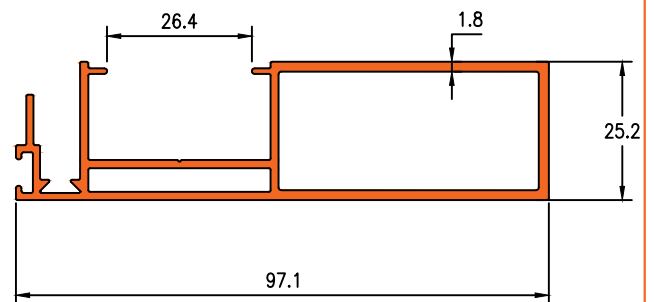

Die No. 23020

0.543 KG/M

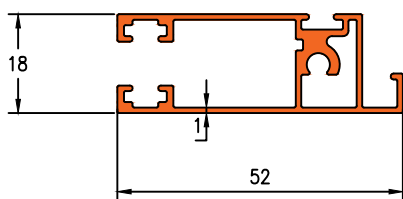

Die No. 16610

0.206 KG/M

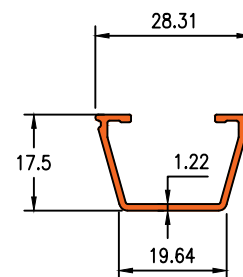

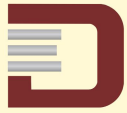

Die No. 16608

0.933KG/M Die No. 16609

0.120 KG/M

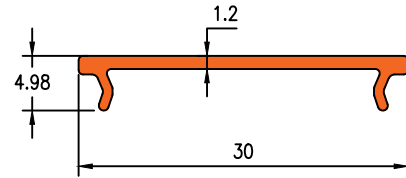
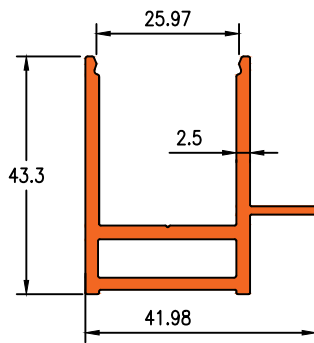



Die No.23187

2.003KG/M

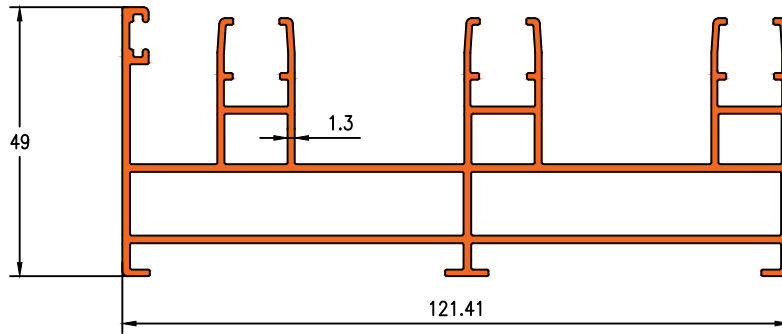

Die No.22109

2.455KG/M

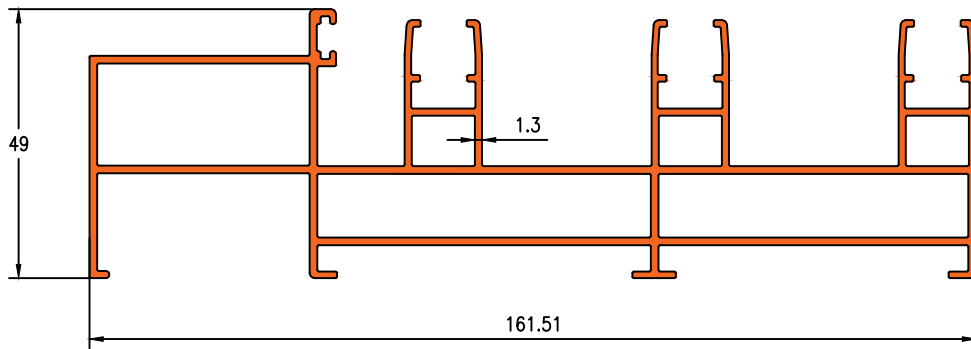



Die No. 16066

1.450KG/M

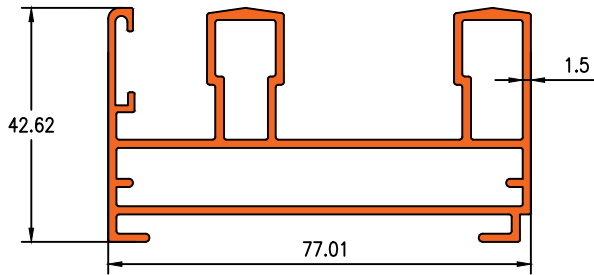

Die No. 19452

1.827KG/M

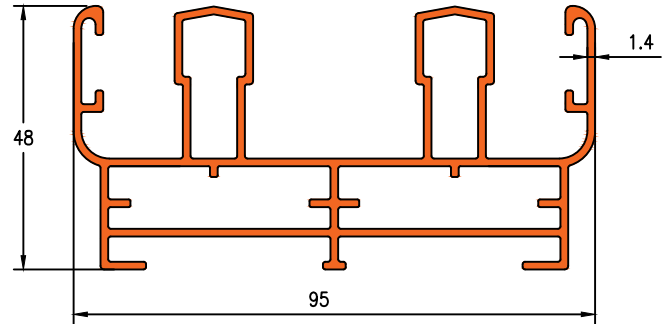

Die No. 19640

2.137 KG/M

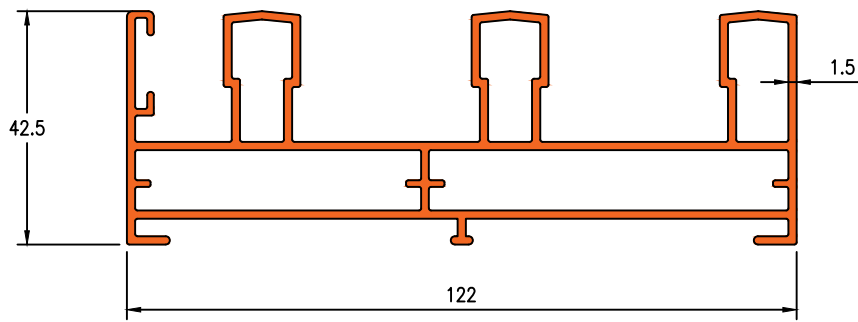

Die No. 16192

2.365KG/M

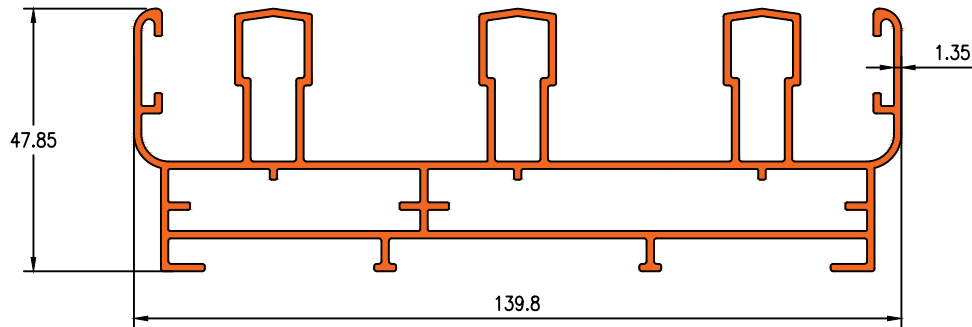

Die No. 16648

2.749KG/M

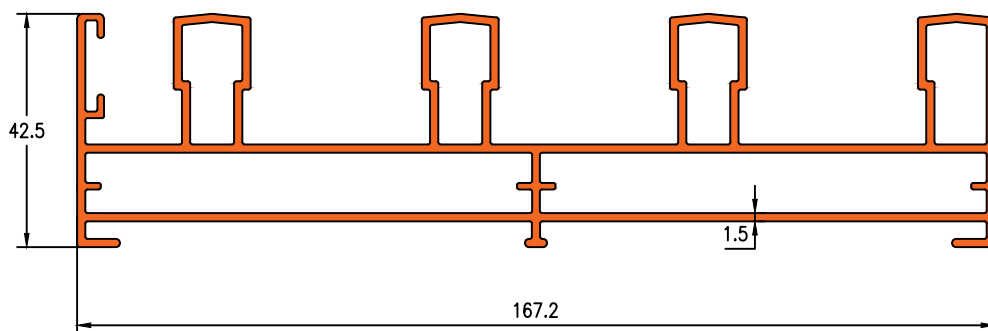



Die No. 19443

0.988KG/M

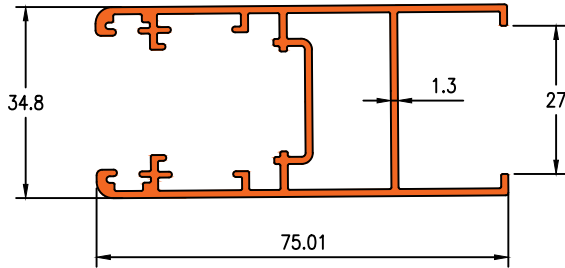

Die No. 16193

1.035KG/M

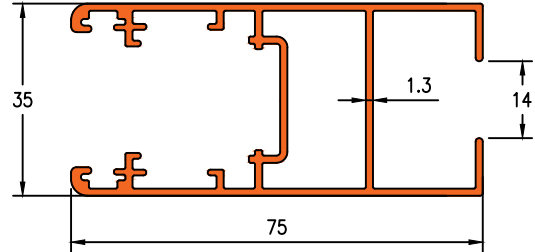

Die No. 16716

1.147KG/M

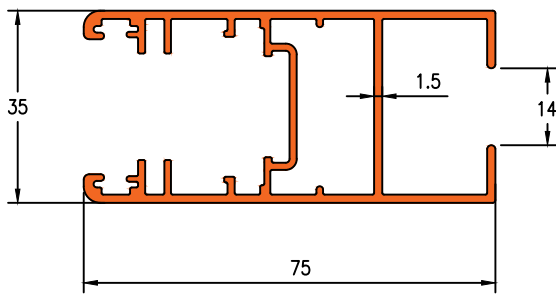

Die No. 16194

0.380KG/M

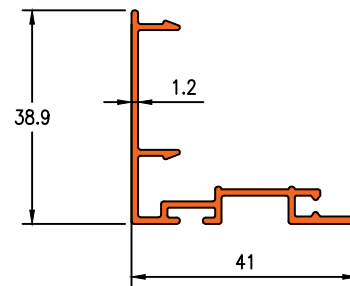

Die No. 20026

0.684KG/M

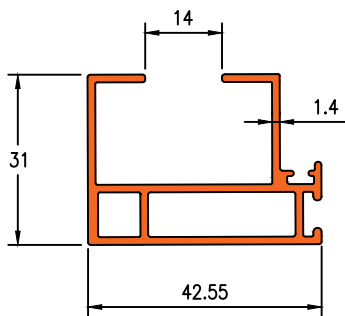

Die No. 20027

0.633KG/M

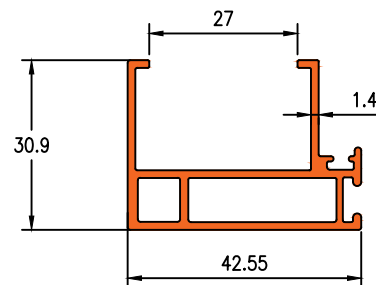

Die No. 16715

1.679KG/M

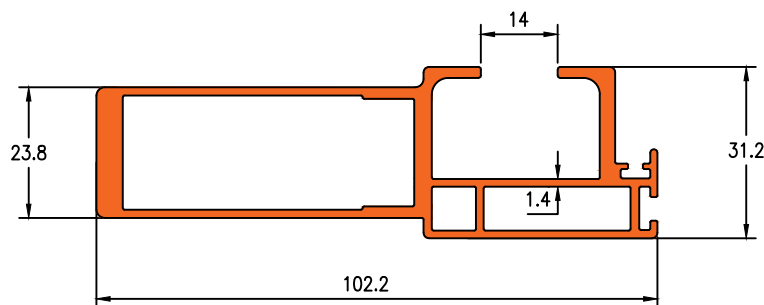



Die No. 16622

1.442KG/M

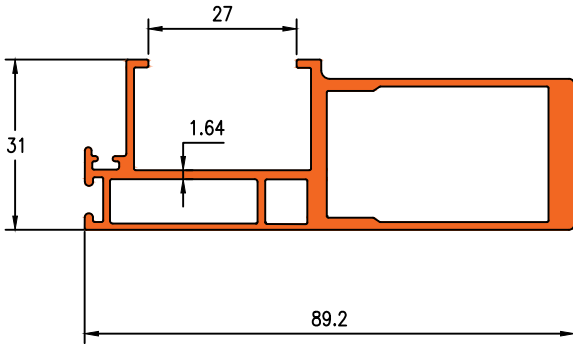

Die No. 16725

0.293KG/M

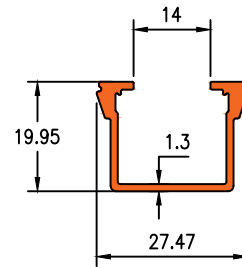

Die No. 20066

1.321KG/M

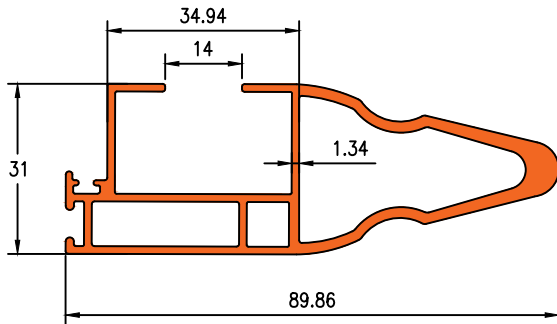

Die No. 21095

1.275KG/M

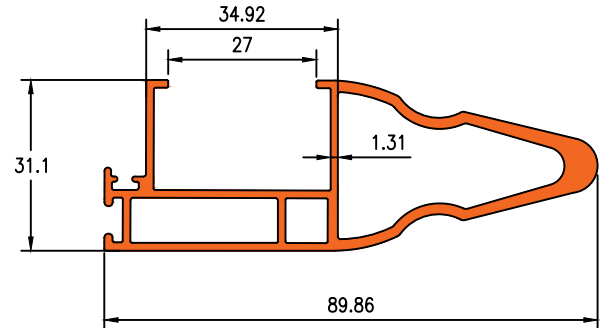



Die No. 21047

1.309KG/M

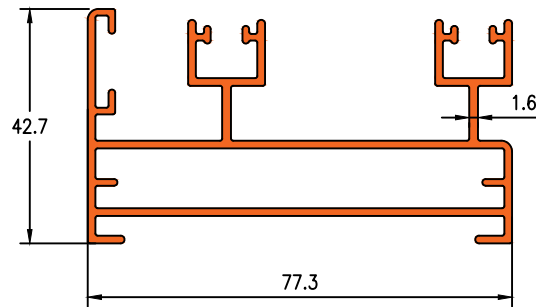

Die No. 21048

1.909KG/M

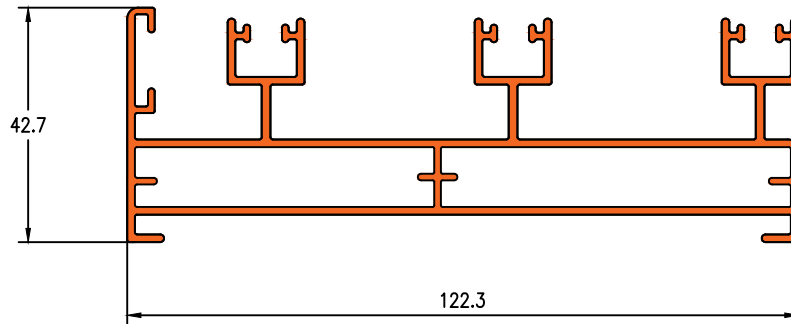

Enq No. 2508

2.312KG/M

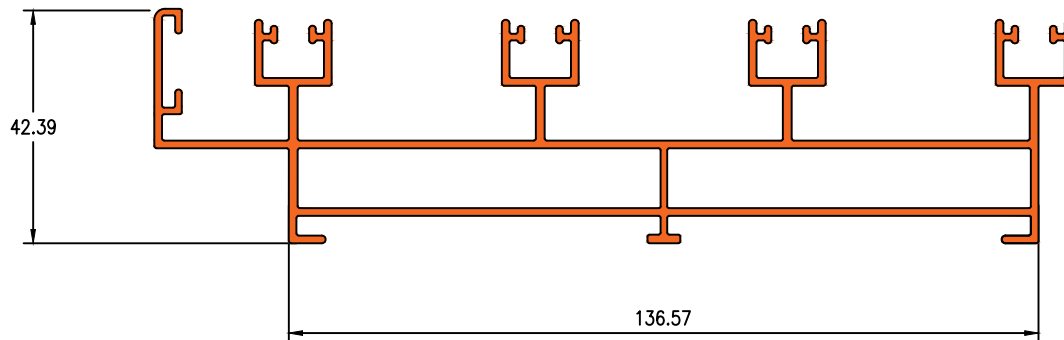

Die No. 20026

0.684KG/M

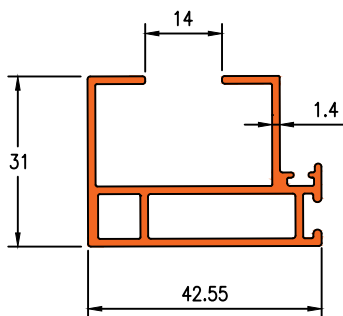

Die No. 20027

0.633KG/M

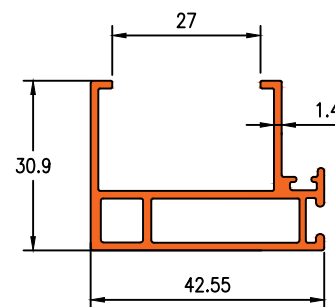

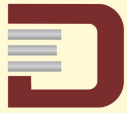

Die No. 20066

1.321KG/M

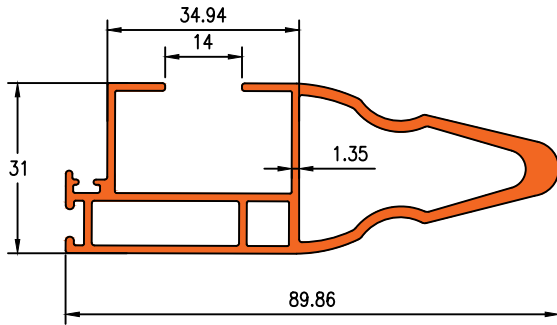

Die No. 21095

1.275KG/M

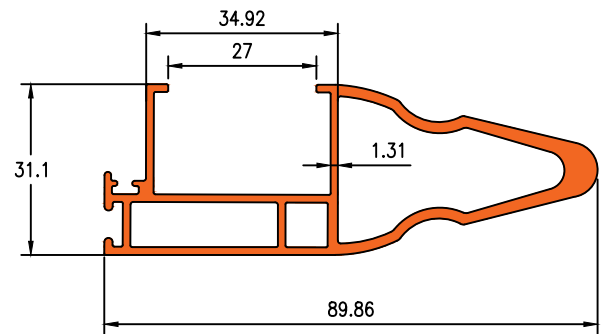

Die No. 16622

1.442KG/M

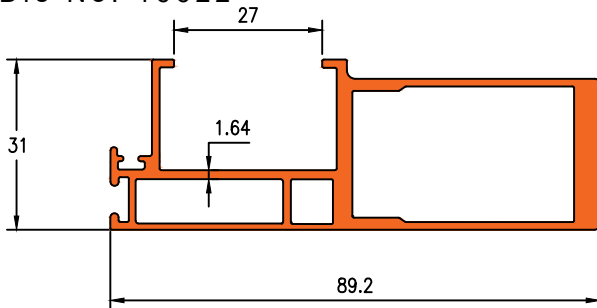

Die No. 16725

0.293KG/M

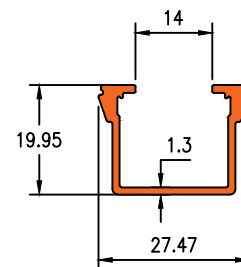

Die No. 16193

1.037KG/M

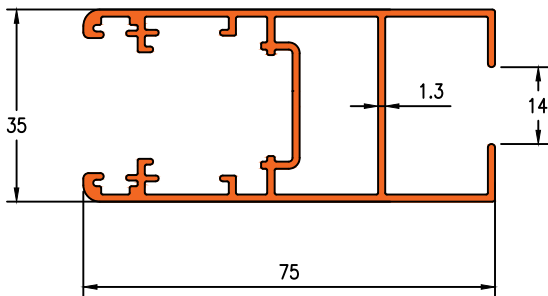

Die No. 19443

0.988KG/M

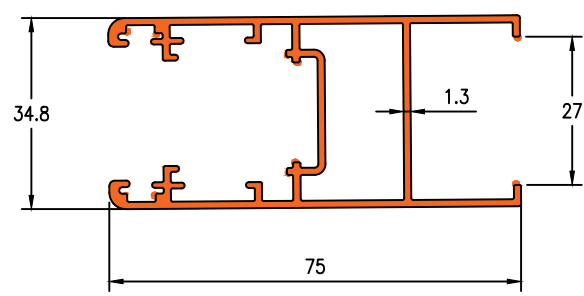

Die No. 16623

0.530KG/M

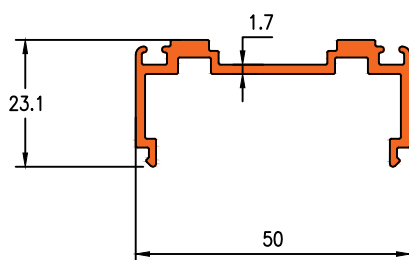

Die No. 16194

0.380KG/M

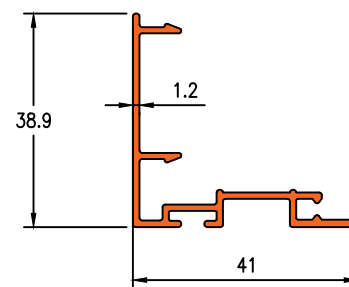



Die No. 28180

1.033KG/M

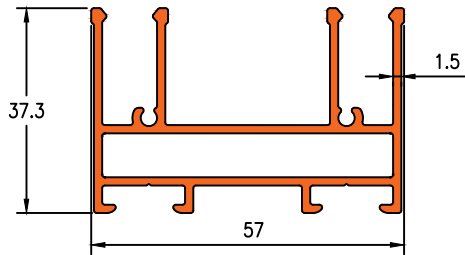

RAIL :- 28183

Die No. 28181

0.276KG/M

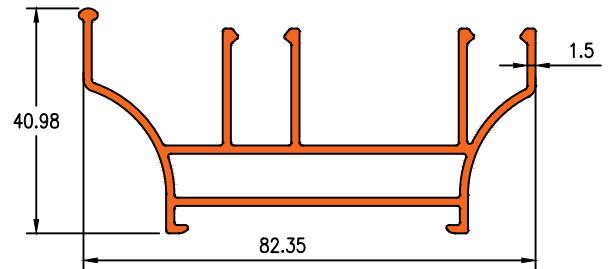

RAIL :- 28183

Die No. 28182

1.678KG/M

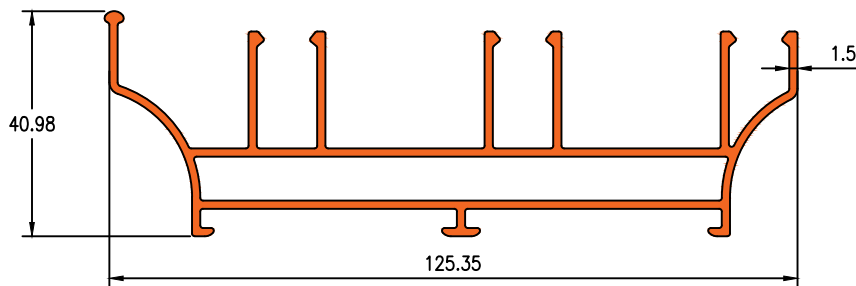

RAIL :- 28183

Die No. 28150

1.132KG/M

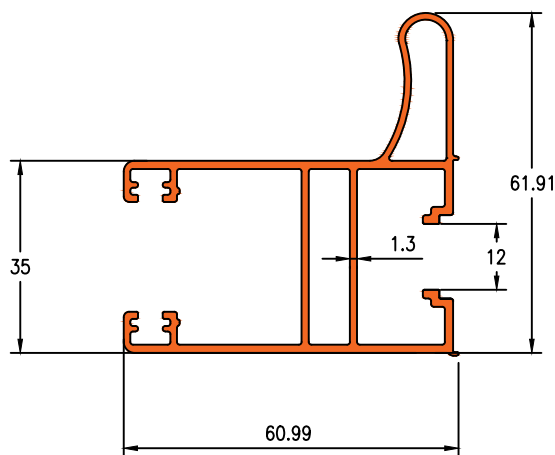

Die No. 28152

1.011KG/M

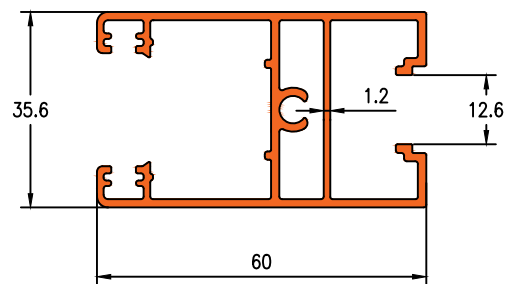

Die No. 28183

0.126KG/M

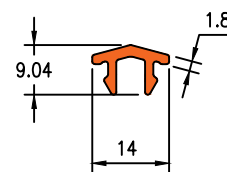

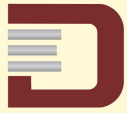

Die No. 28153

0.779KG/M

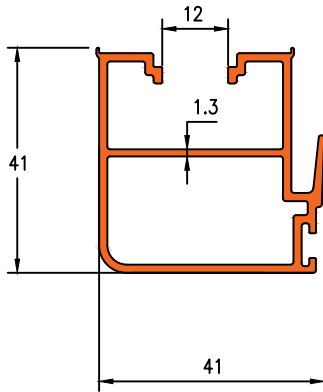

Die No. 28154

0.922KG/M

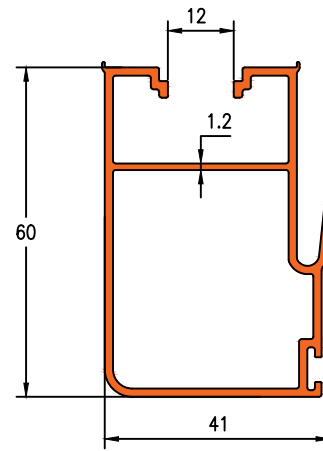

Die No. 28148

1.417KG/M

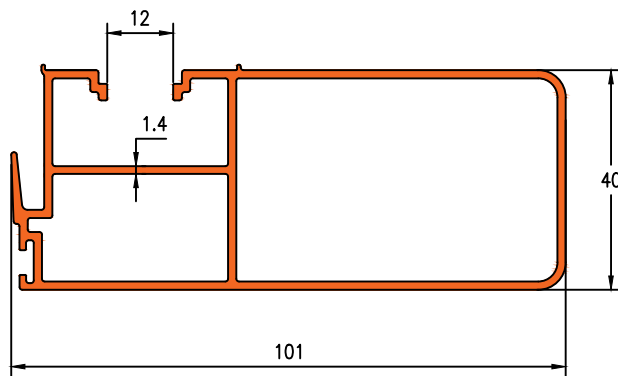

Die No. 28151

1.093KG/M

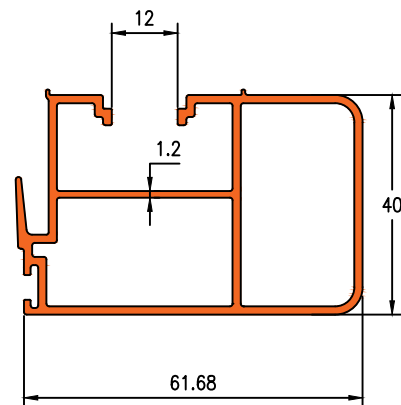



Die No. 16054

1.214KG/M

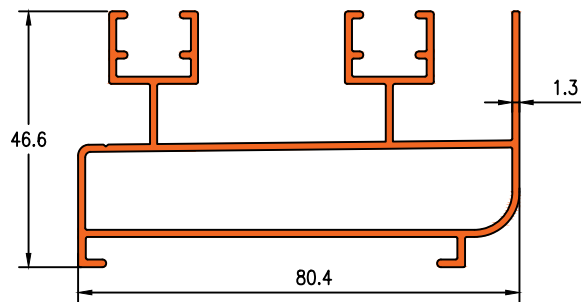

Die No. 16049

0.832KG/M

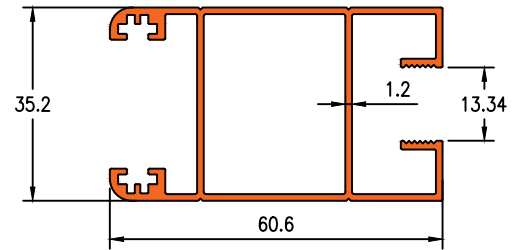

Die No. 16050

0.798KG/M

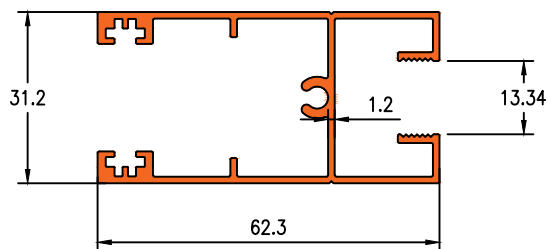

Die No. 16051

0.846KG/M

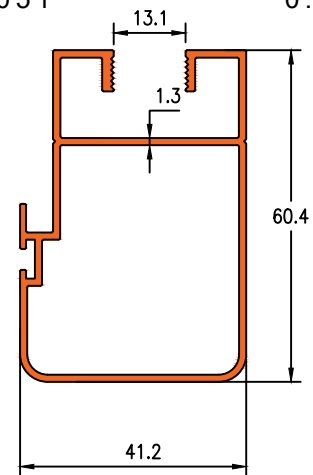



Die No. 16223

1.574KG/M

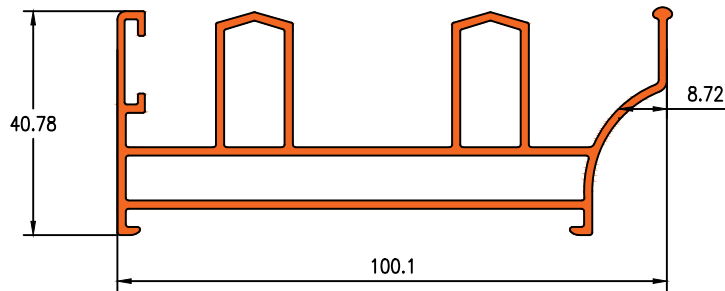

Die No. 16222

2.226KG/M

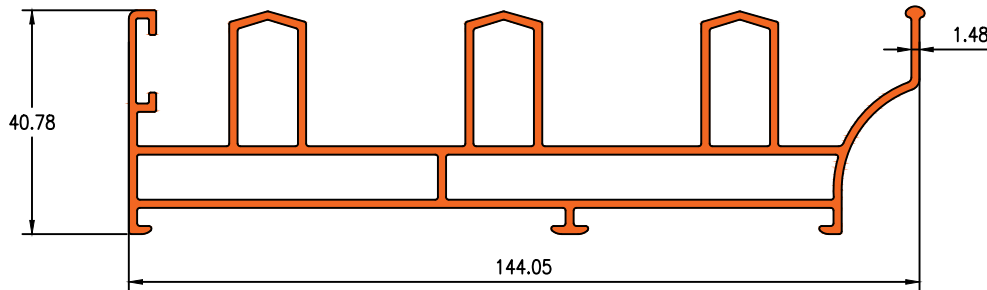

Die No. 16221

1.042KG/M

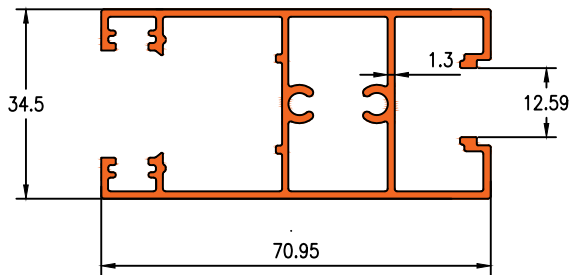

Die No. 16220

1.126KG/M

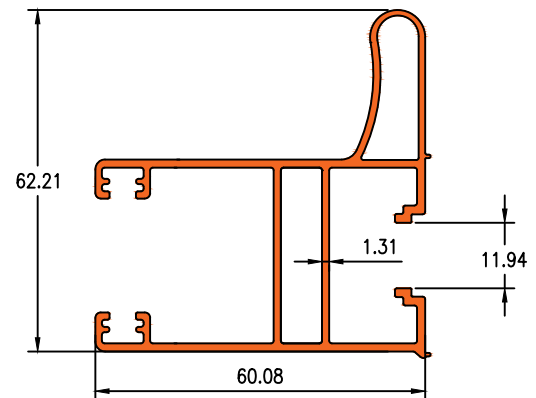

Die No. 2844

1.104KG/M

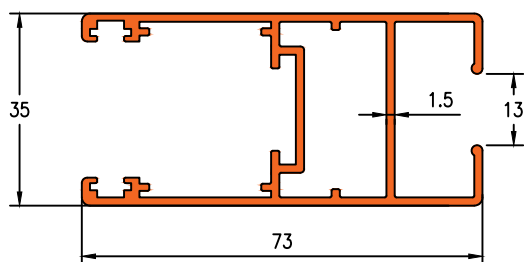

Die No. 16219

0.792KG/M

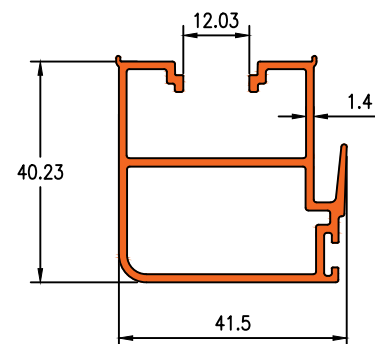



Die No. 2842

0.110KG/M

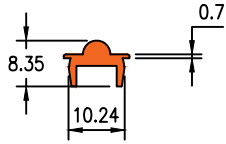

Die No. 2845

0.414KG/M

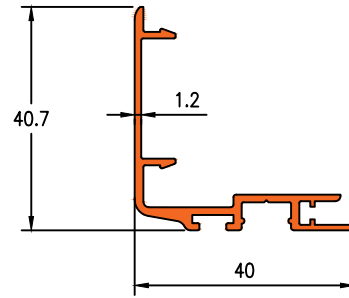

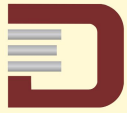

Die No. 16596

1.296KG/M

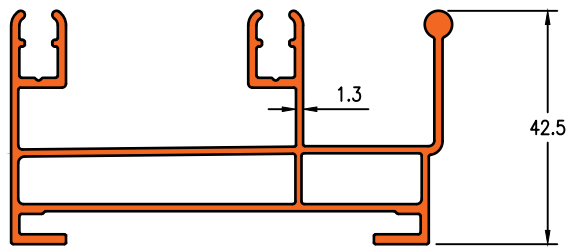

Die No. 16595

1.914KG/M

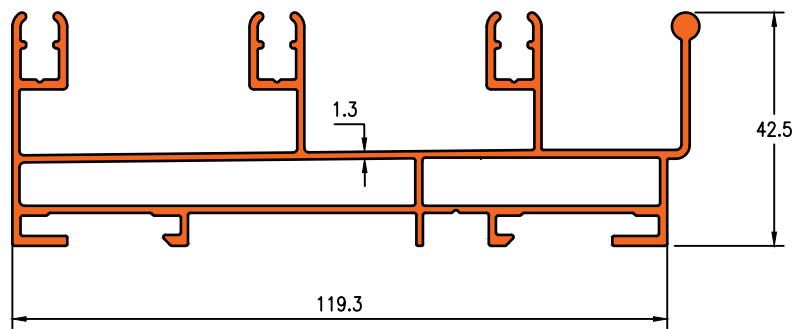

Die No. 21188

1.077KG/M

Die No. 21189

0.929 KG/M

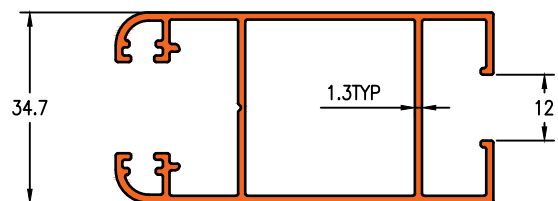
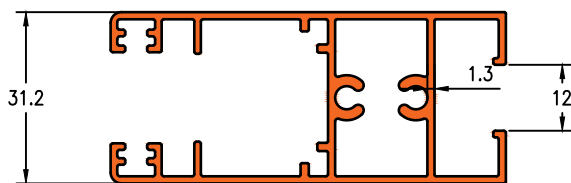

Die No. 16597

0.661 KG/M

Die No. 16598

1.053 KG/M

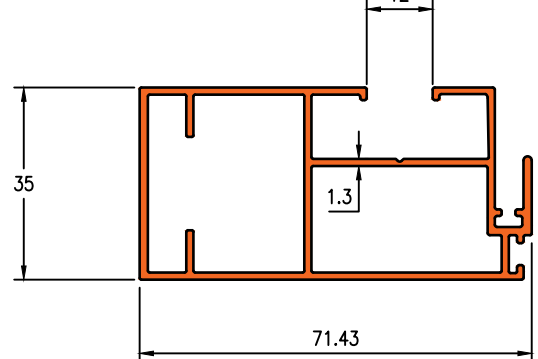
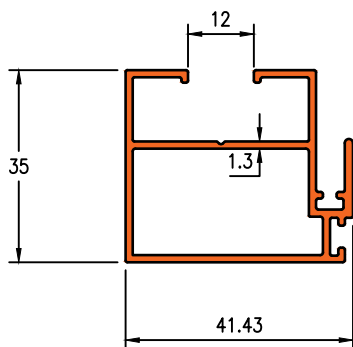

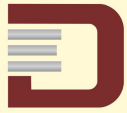

Die No. 16599

1.497KG/M

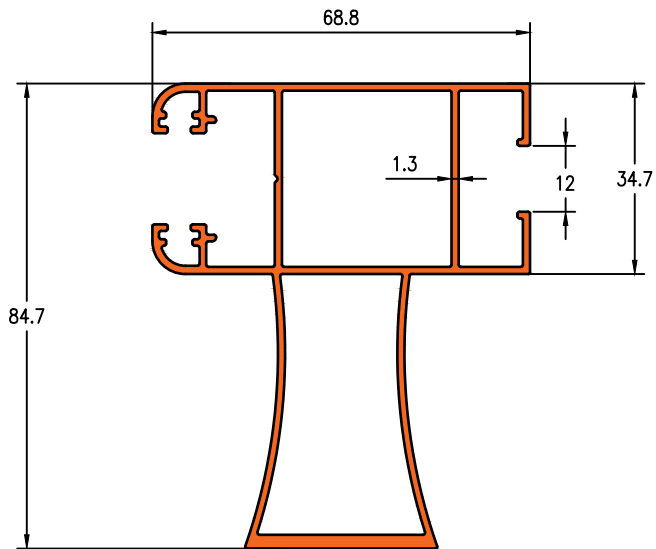

Die No. 21191

0.129 KG/M

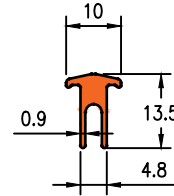

Die No. 21190

0.282 KG/M

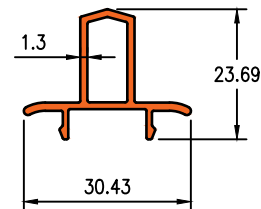

Enq No. 1864

0.667KG/M

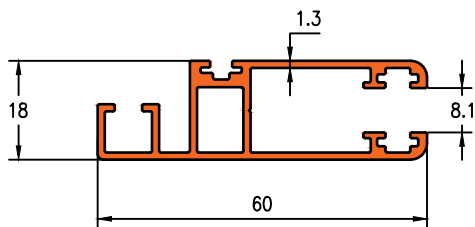

Enq No. 1865

0.208KG/M

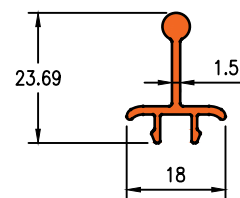

Enq No. 1867

0.476KG/M

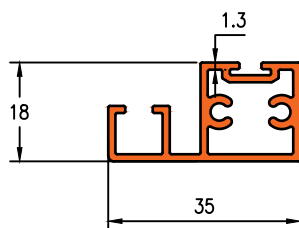



Enq No. 1970

1.045 KG/M

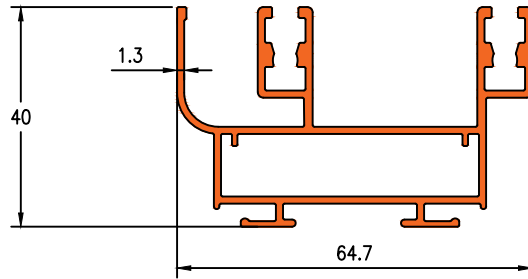

Enq No. 1965

0.873 KG/M

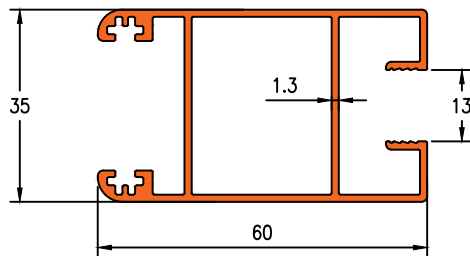

Enq No. 1963

1.161 KG/M

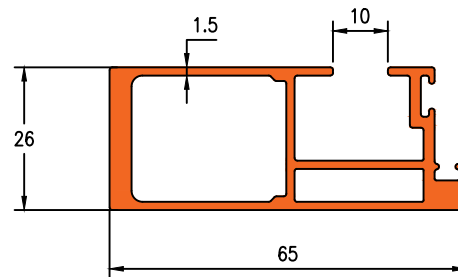

Enq No. 1964

0.835 KG/M

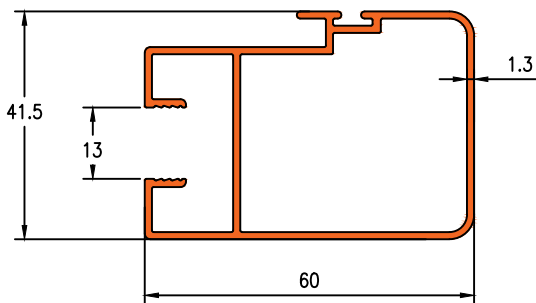

Enq No. 1968

1.164 KG/M

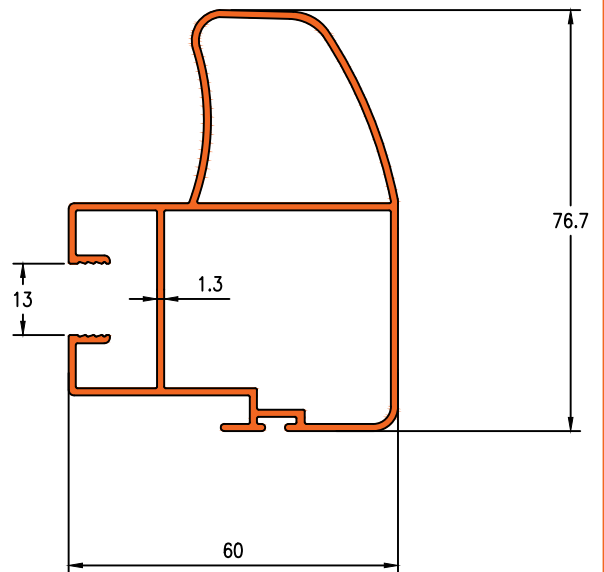

Enq No. 1966

0.757 KG/M

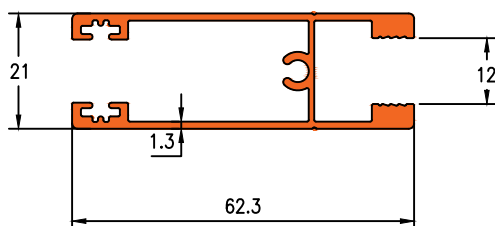



Enq No. 1969

0.972 KG/M

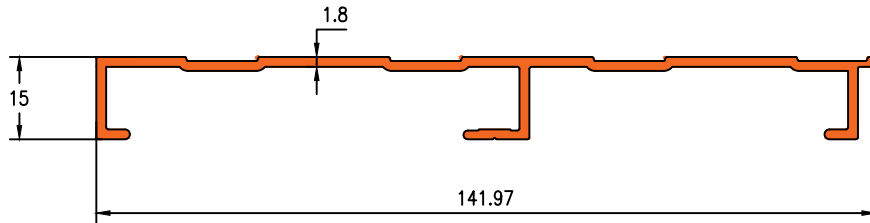

Enq No. 1967

1.085 KG/M

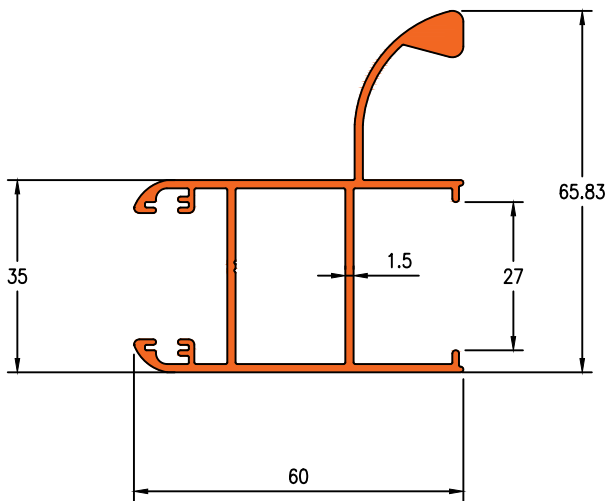



Enq No. 2018

1.667 KG/M

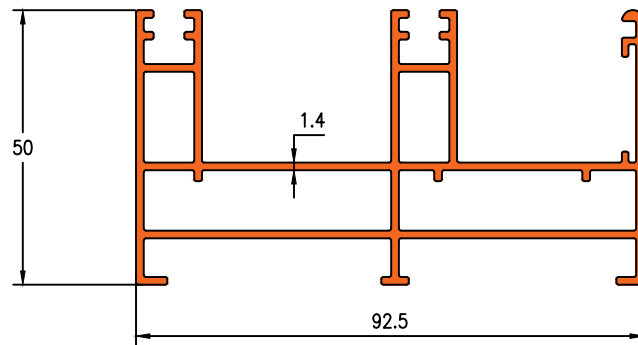

Enq No. 2020

1.460 KG/M

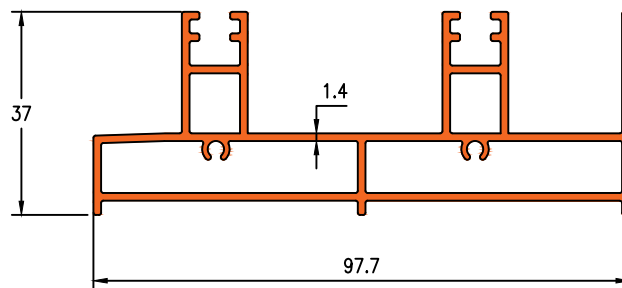

Enq No. 2019

2.401 KG/M

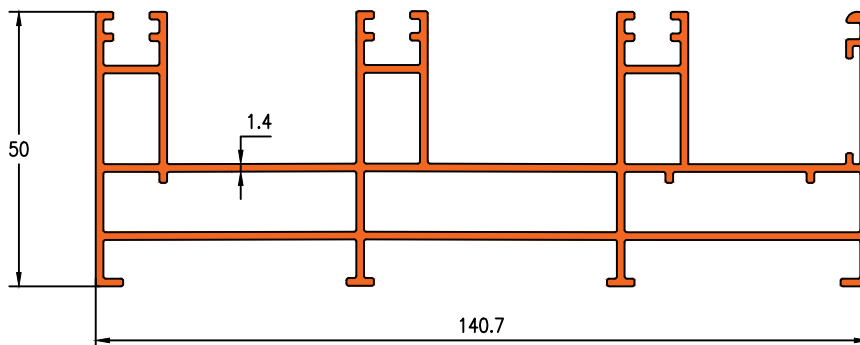

Enq No. 2021

2.086 KG/M

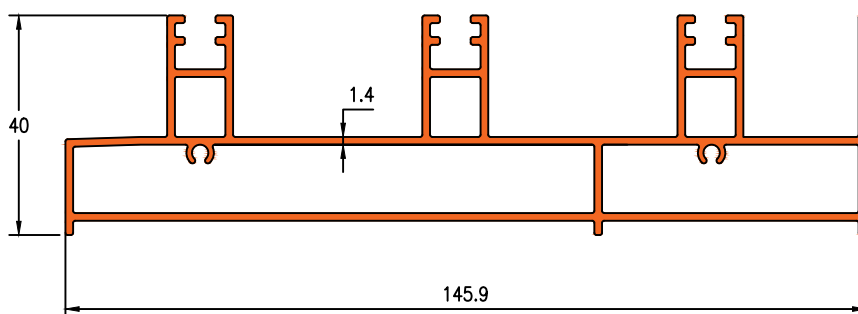



Enq No. 2014

1.105 KG/M

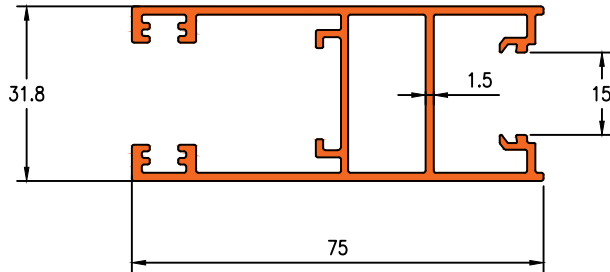

Enq No. 2015

1.016 KG/M

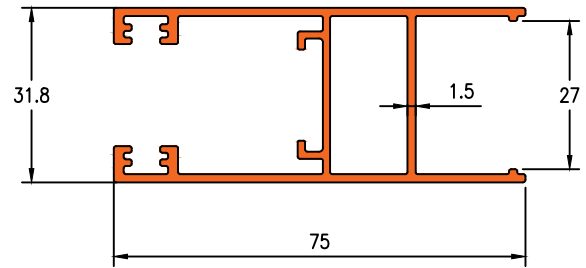

Enq No. 2016

0.810 KG/M

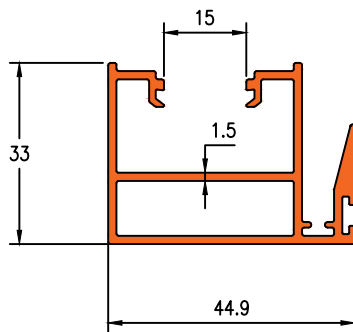

Enq No. 2017

1.260 KG/M

