

Die No. 16009

0.080KG/M

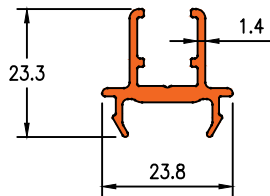

Die No. 16004

1.312KG/M

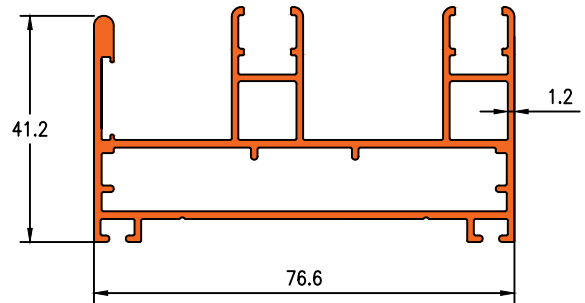

Die No. 16005

1.760KG/M

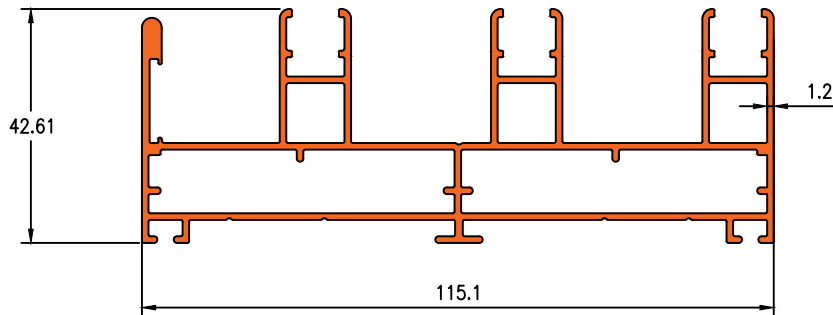

Die No. 16539

2.345KG/M

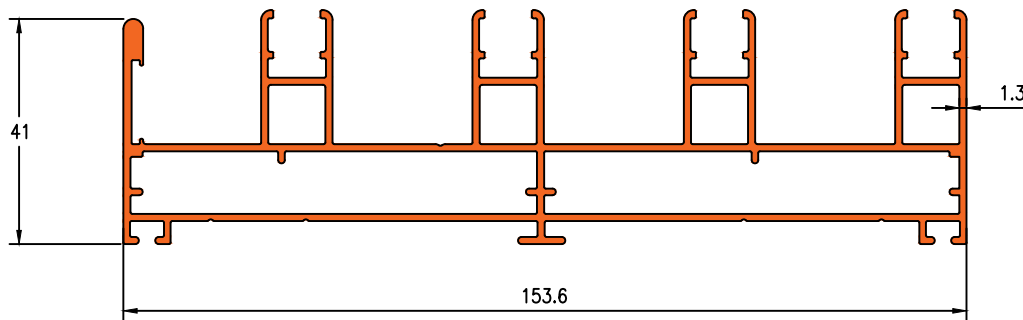

Die No. 16006

0.863 KG/M

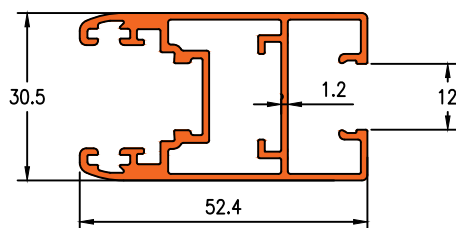

Die No. 16008

0.182KG/M

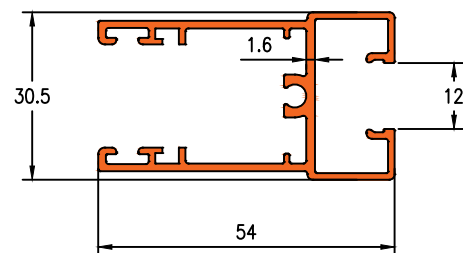



Die No. 16541

1.020KG/M

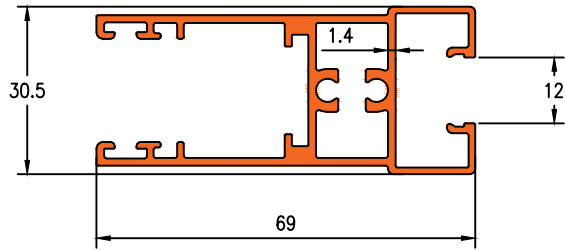

Die No. 16007

0.685KG/M

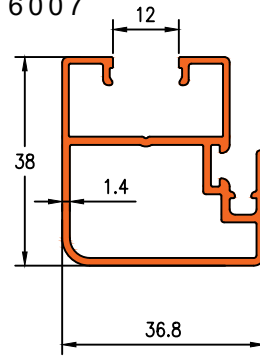

Die No. 23020

0.543KG/M

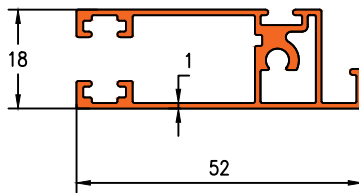

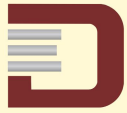

Darshan Extrusions Pvt. Ltd.

Die No.16181

1.023KG/M

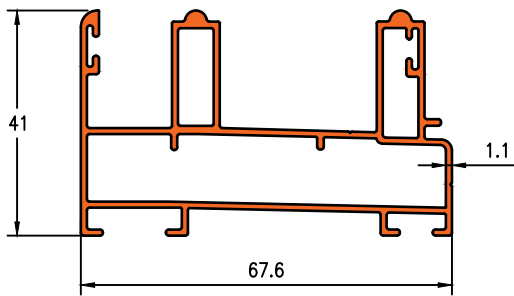

Die No.16014

1.451KG/M

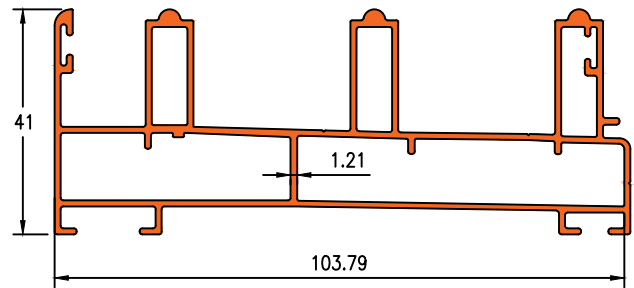

Die No.16134

1.956KG/M

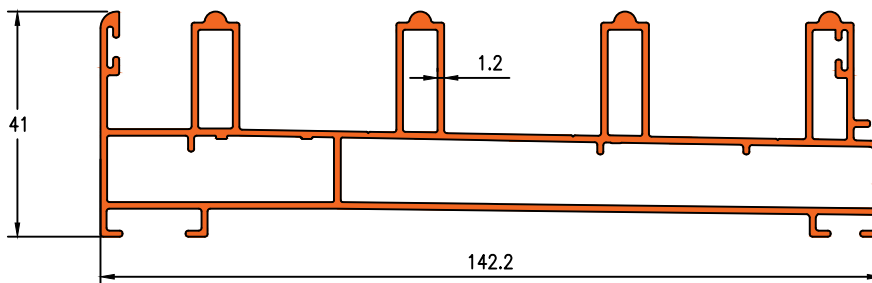

Die No. 7128

1.057KG/M

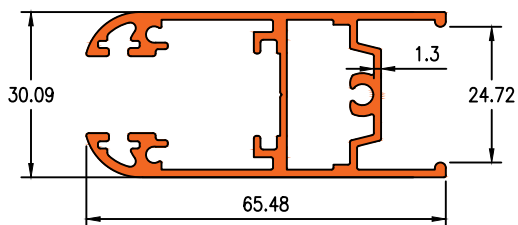

Die No. 7129

0.812KG/M

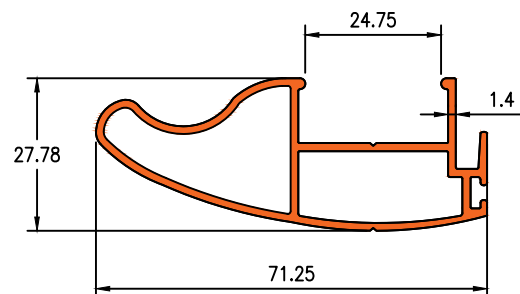

Die No. 16013

0.543KG/M

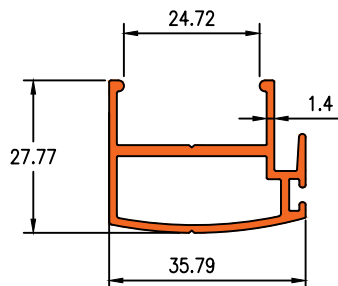

Die No. 16012

0.194KG/M

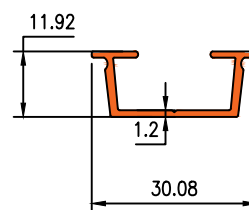

30 MM SERIES



Die No. 19621

0.795KG/M

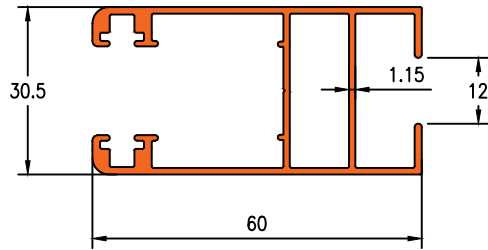

Die No. 19624

1.128KG/M

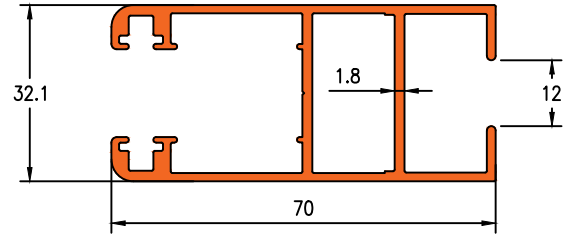

Die No. 19822

1.039KG/M

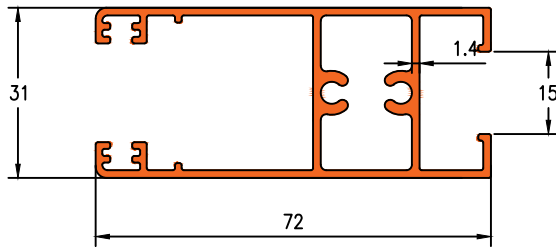

Die No. 19623

1.082KG/M

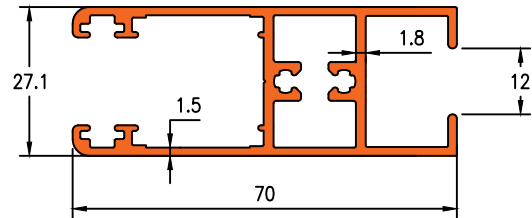

Die No. 16063

0.307KG/M

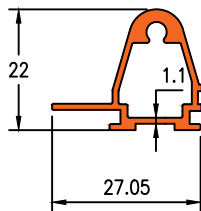

Die No. 19622

0.318KG/M

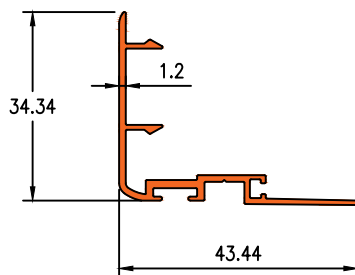

Die No. 19619

0.304KG/M

