

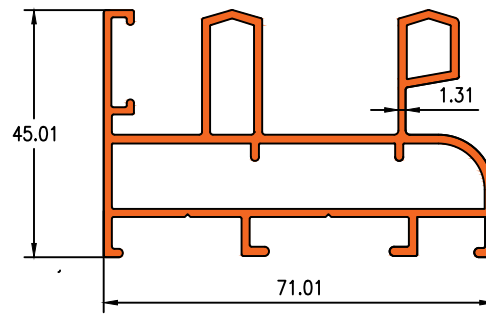

Die No. 16218

1.387KG/M



Die No. 16205

2.006KG/M

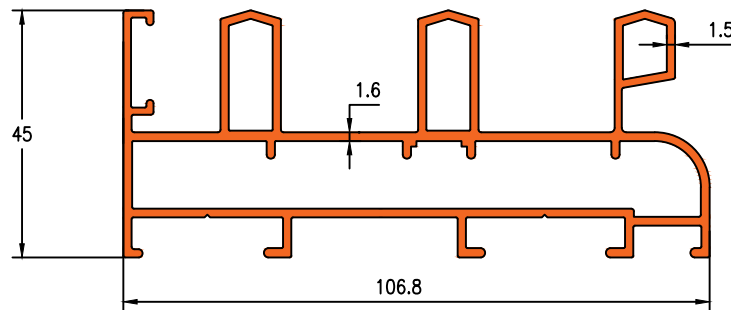

Die No. 19901

1.985KG/M

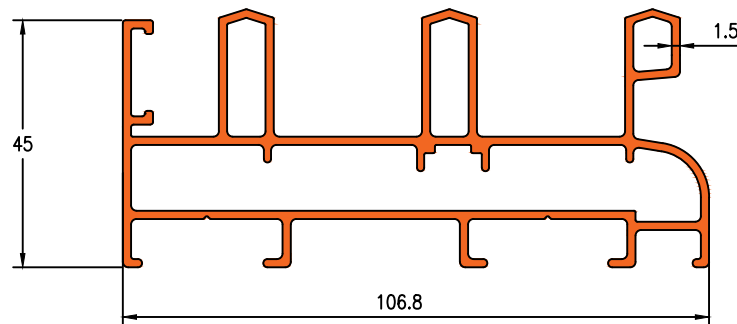

Die No. 16206

0.826KG/M

Die No. 19444

0.267KG/M

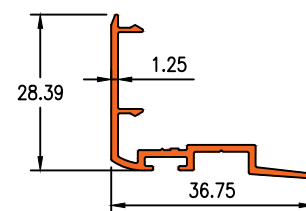
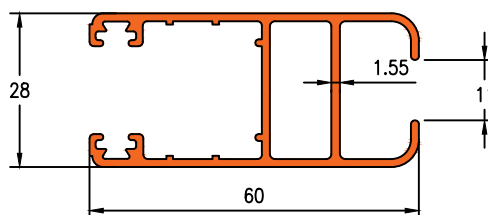

CLIP : 19444 & 2709



Die No. 2812

0.770KG/M

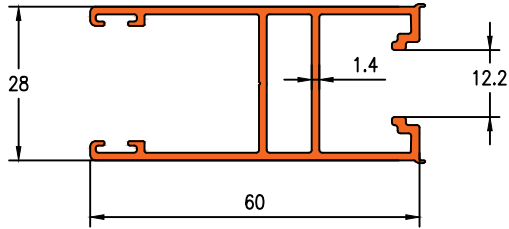

Die No. 2813

0.690KG/M

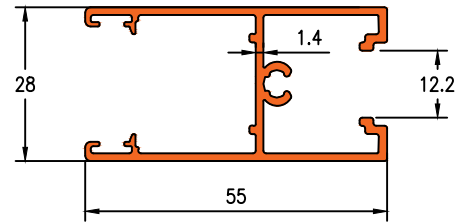

Die No. 2814

0.834KG/M

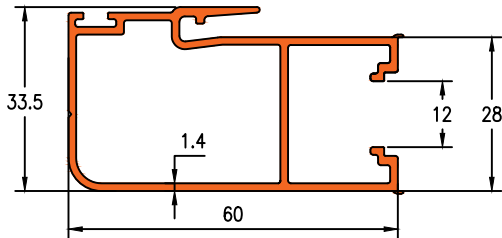

Die No. 2815

1.141KG/M

