

Die No. 21074

1.029KG/M

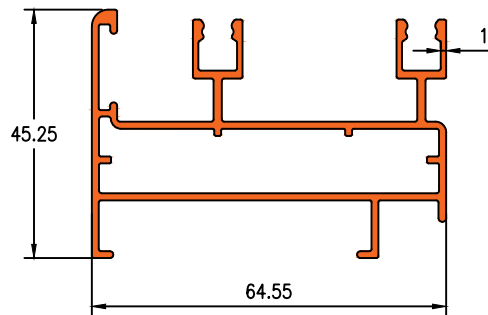

Die No. 21059

1.409KG/M

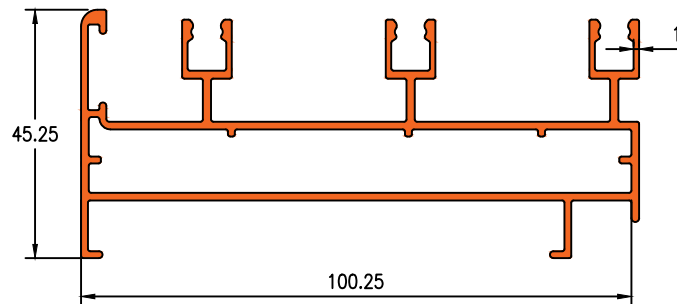

Die No. 23091

2.059KG/M

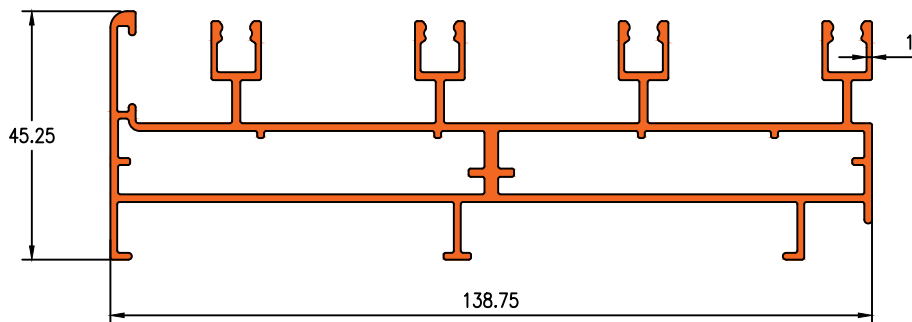

Die No. 21094

0.057 KG/M

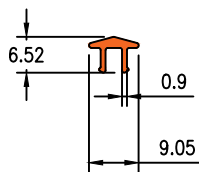



Die No. 21113

0.996KG/M

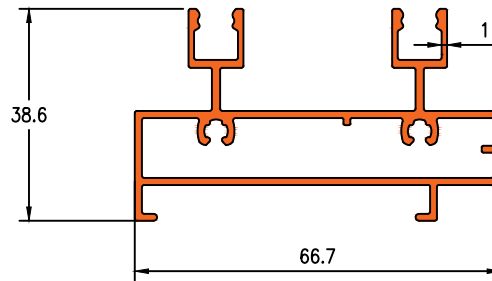

Die No. 21114

1.394KG/M

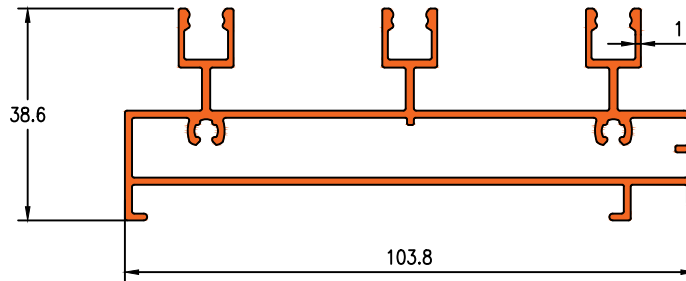

Die No. 21115

0.519KG/M

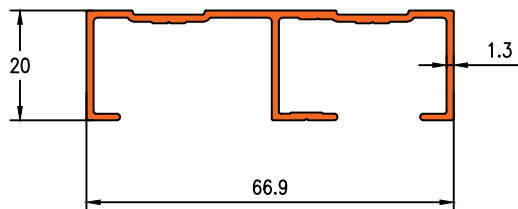

Die No. 21116

0.651KG/M

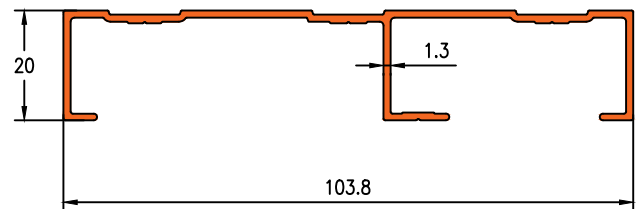

Die No. 21119

0.685KG/M

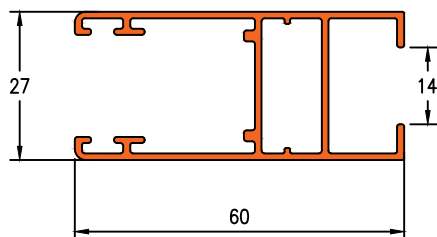

Die No. 21117

0.145KG/M

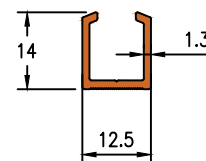

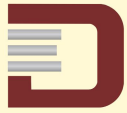

Die No. 21118

0.512KG/M

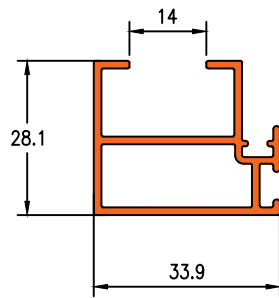

Die No. 21183

0.817KG/M

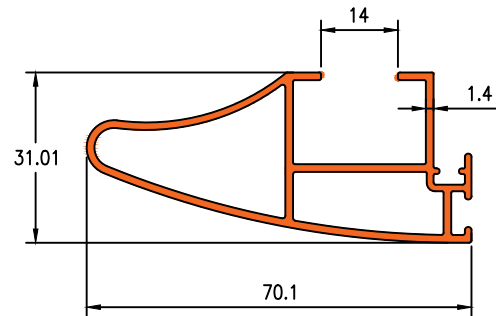

Die No. 16694

1.037KG/M

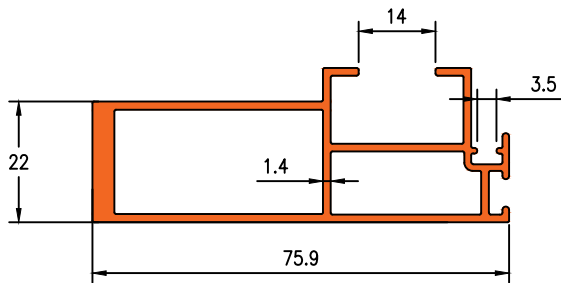



Darshan Extrusions Pvt. Ltd.

Die No. 1343

0.970KG/M

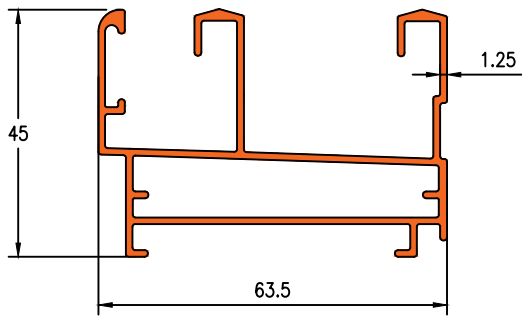

Die No. 21041

0.789KG/M

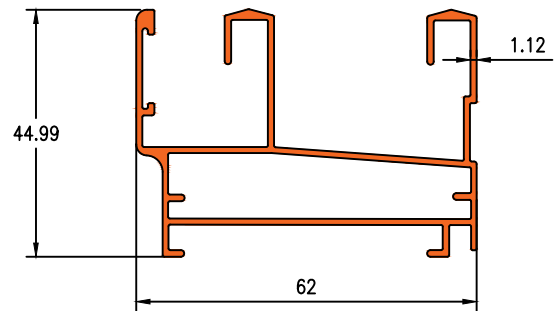

Die No. 1332

1.444KG/M

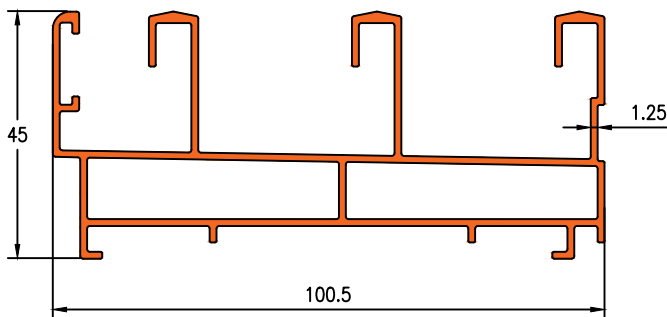

Die No. 21042

1.303KG/M

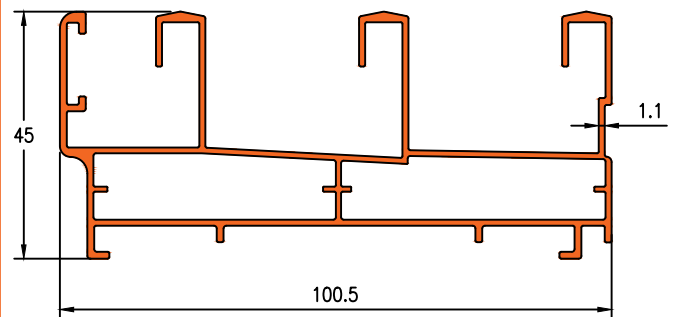

Die No. 28193

1.835KG/M

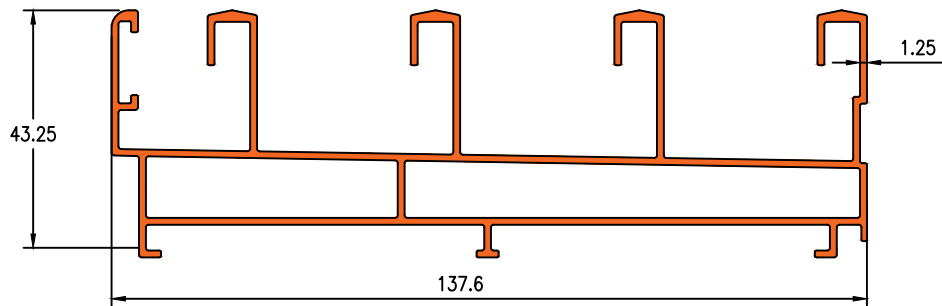

Die No. 1333

0.690KG/M

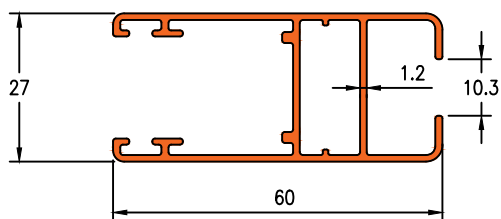

CLIP : 1331

Die No. 16180

0.675KG/M

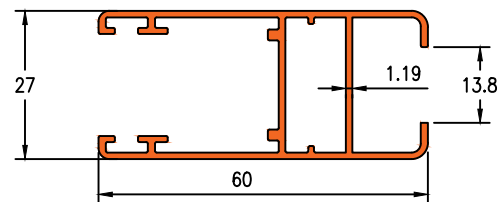

CLIP : 1331

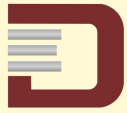

Die No. 19735

0.644KG/M

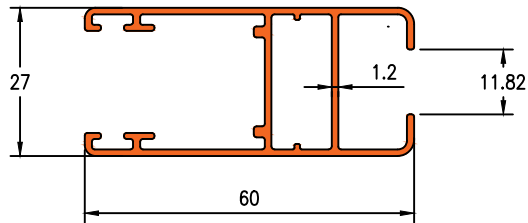

Die No. 1331

0.322KG/M

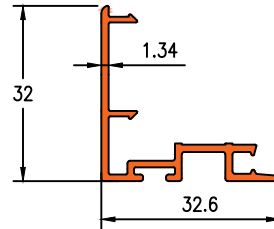

Die No. 20028

0.549KG/M

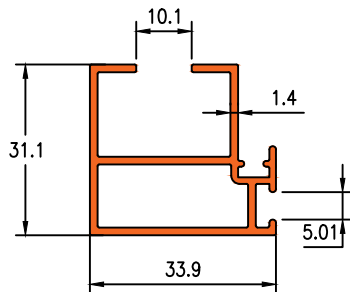

Die No. 20029

0.499KG/M

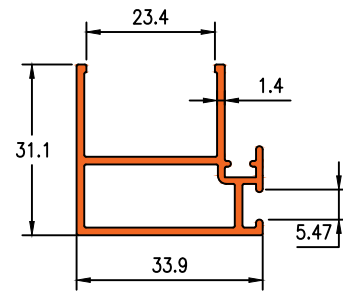

Die No. 20065

1.204KG/M

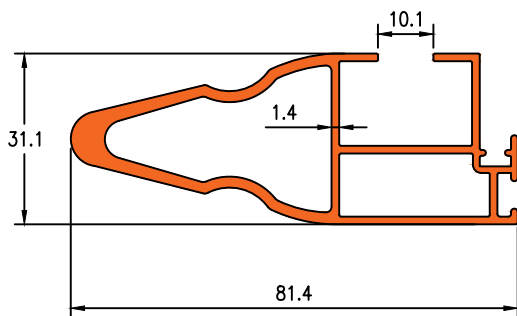

Die No. 21096

1.154KG/M

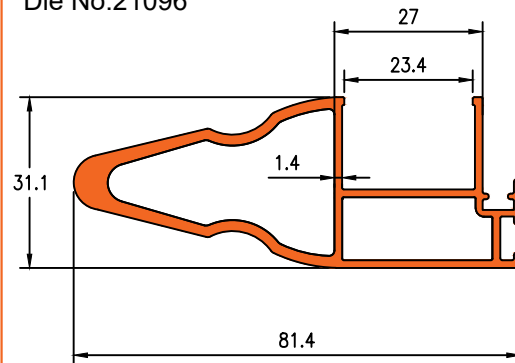

Die No. 19376

0.680KG/M

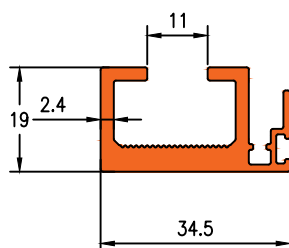

Die No. 19332

1.394KG/M

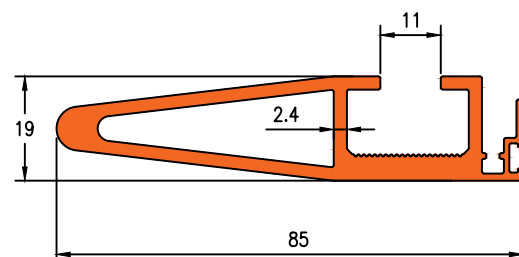



Die No. 2701

0.719KG/M

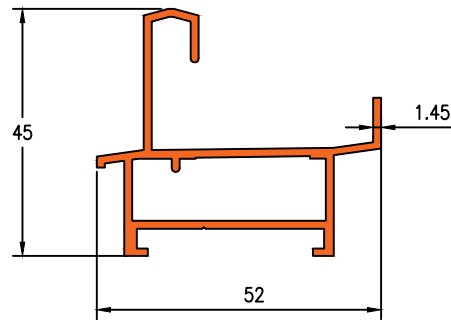

Die No. 2702

0.871KG/M

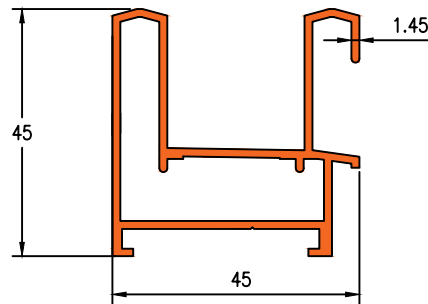

Die No. 2703

1.398KG/M

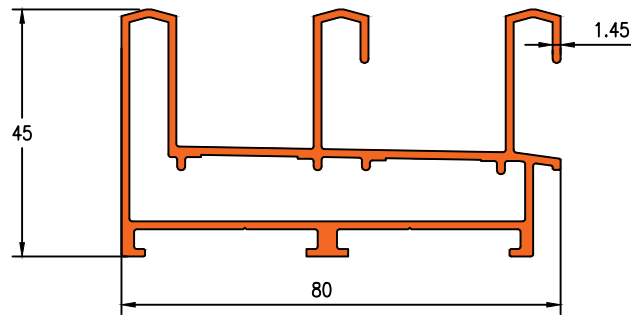

Die No. 2704

1.905KG/M

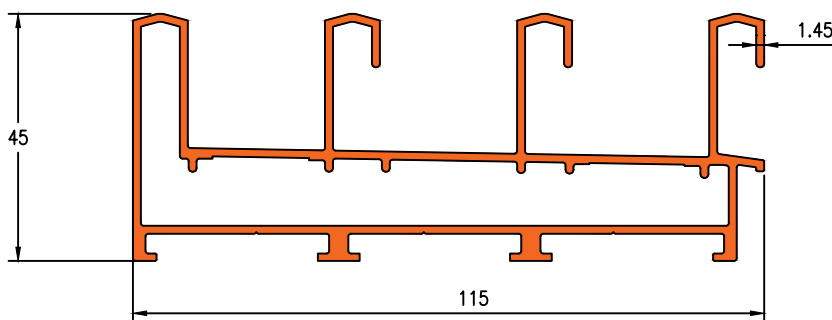



Die No. 2708

0.862KG/M

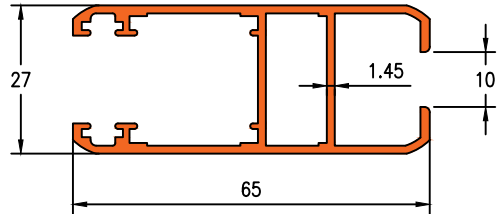

CLIP :2709 & 16141

Die No. 2707

0.890KG/M

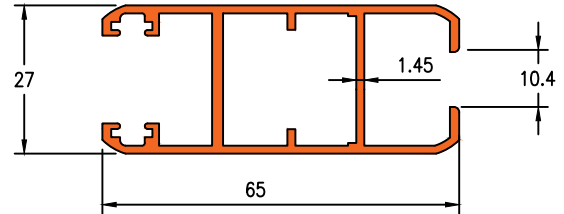

CLIP :2709 & 16141

Die No. 2705

0.810 KG/M

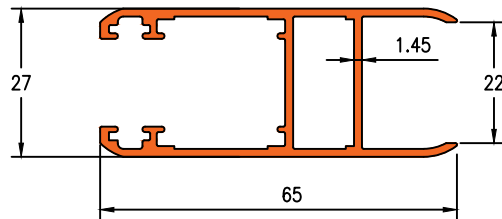

CLIP :2709 & 16141

Die No. 2706

0.838KG/M

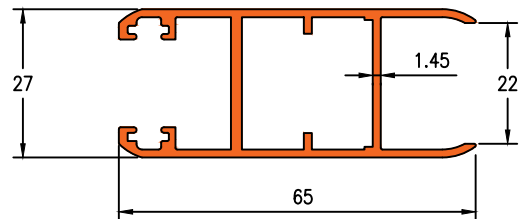

CLIP :2709 & 16141

Die No. 2709

0.273KG/M

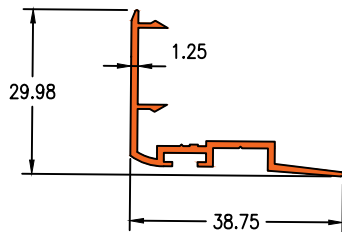

Die No. 2710

0.262KG/M

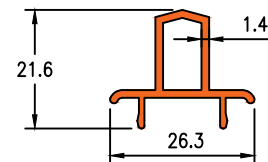



Die No. 19371

1.535KG/M

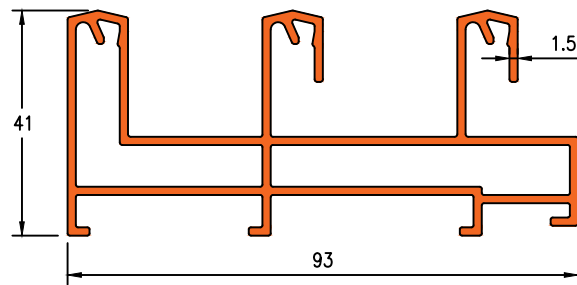

Die No. 19372

2.167KG/M

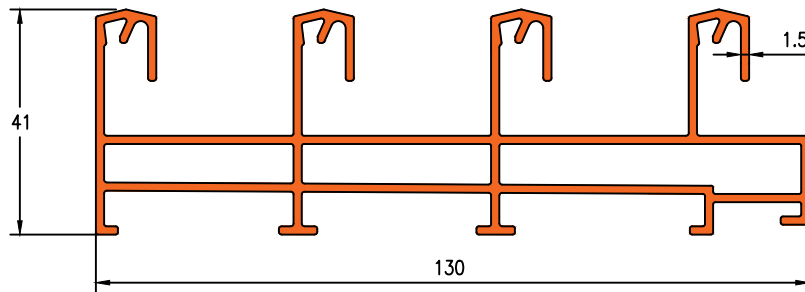

Die No. 21044

0.701KG/M
0.750KG/M

Die No. 19370

0.797KG/M

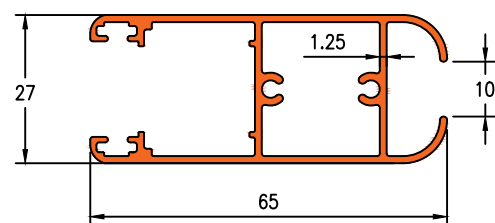
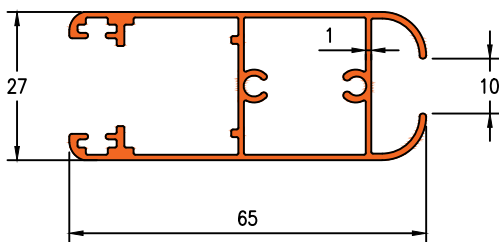

Die No. 21043

0.308KG/M

Die No. 21103

0.302KG/M

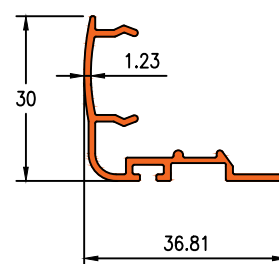
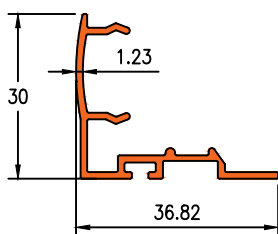

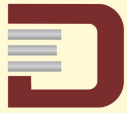

Die No. 1211

0.693KG/M

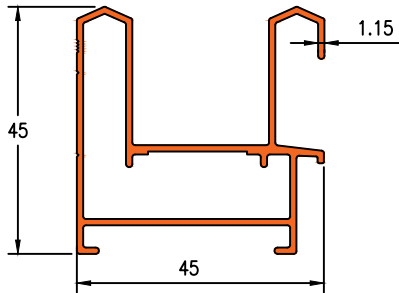

Die No. 1210

1.081KG/M

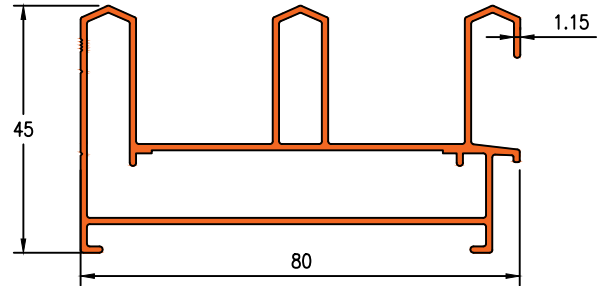

Die No. 1212

0.755KG/M
0.855 KG/M

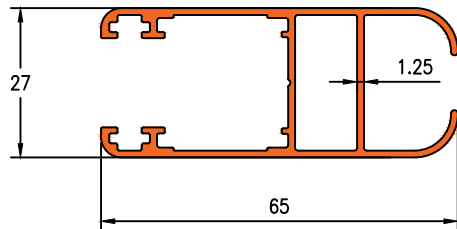

CLIP : 1213

Die No. 1213

0.260KG/M

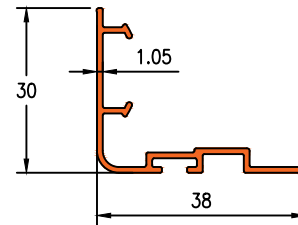

Die No. 16177

1.262KG/M

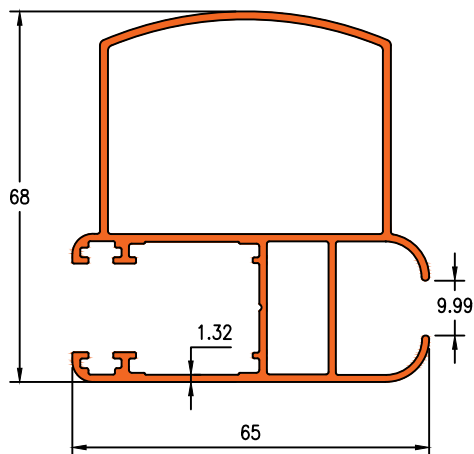

CLIP : 1213

Die No. 28197

0.681KG/M

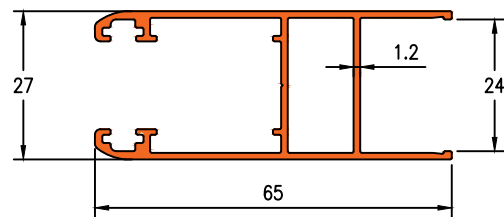

Die No. 28192

0.272KG/M

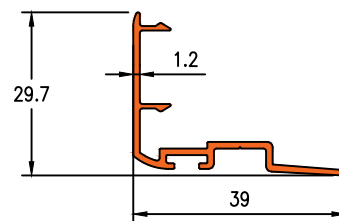



Die No.21214

1.045KG/M

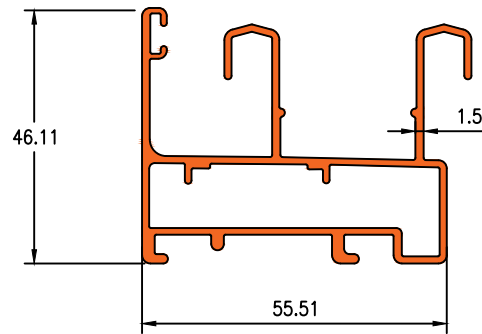

Die No.21213

1.473KG/M

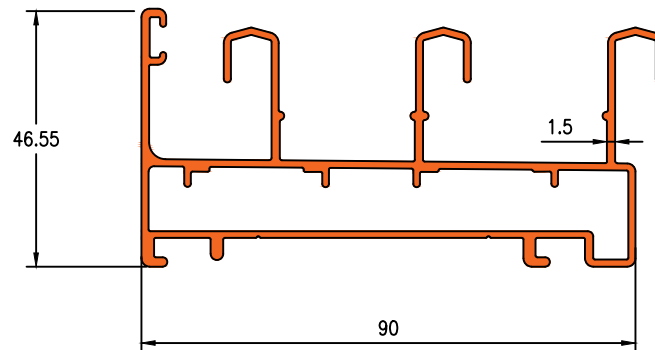

Die No.21215

1.775KG/M

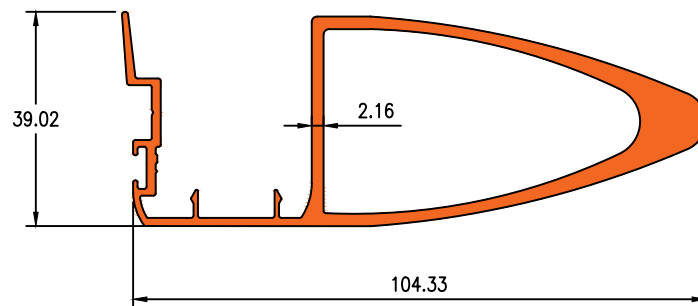

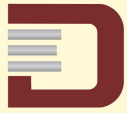

Die No. 16197

1.108KG/M

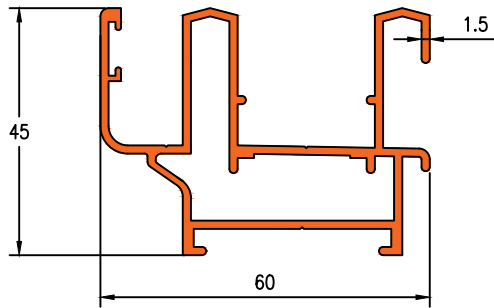

Die No. 16195

1.586KG/M

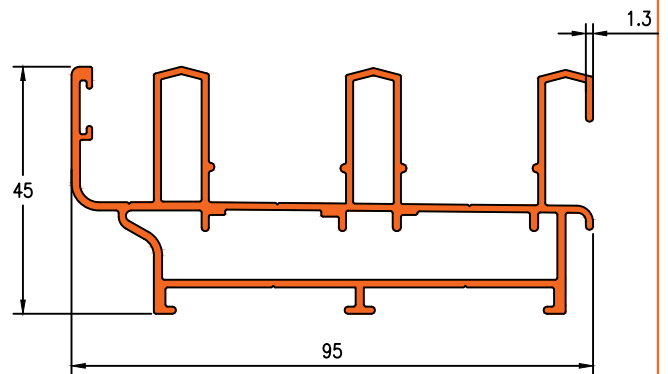

Die No. 19474

1.107KG/M

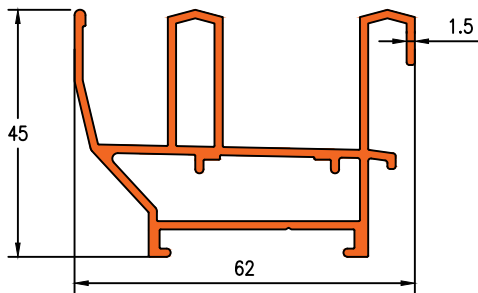

Die No. 16199

0.247KG/M

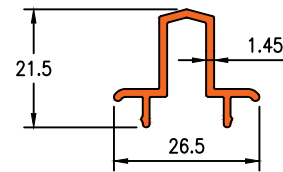

Die No. 16200

0.860KG/M

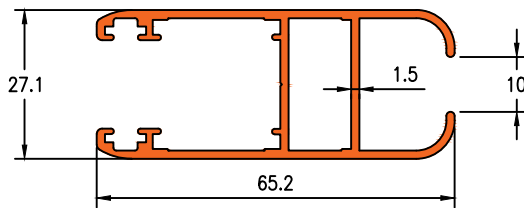

Die No. 16198

0.829KG/M

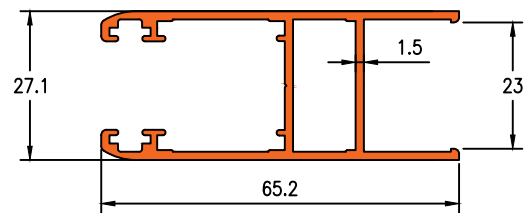

Die No. 16209

1.180KG/M

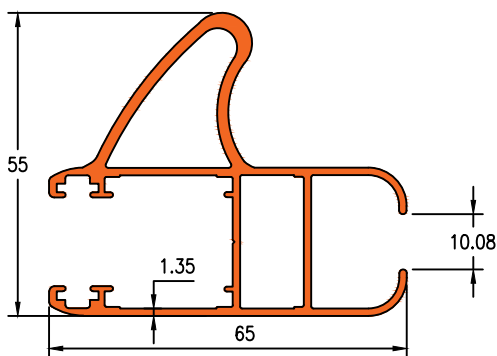

Die No. 16196

0.272KG/M

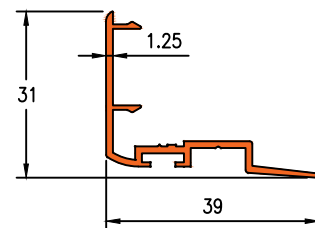

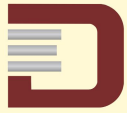

Die No. 19625

1.865KG/M

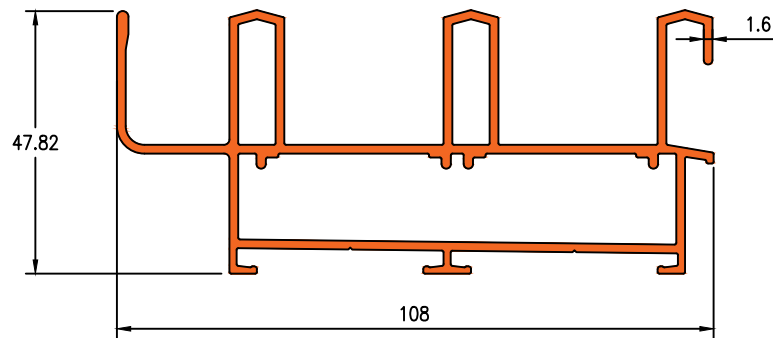

Die No. 19626

1.185KG/M

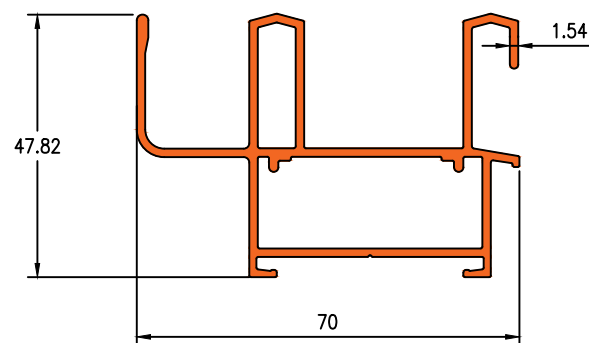

Die No. 19620

0.779KG/M

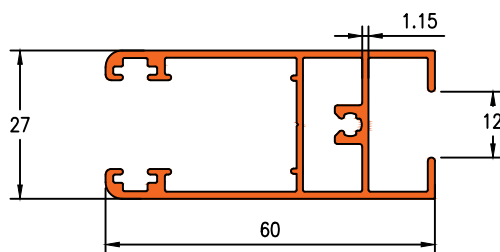

Die No. 19623

1.082KG/M

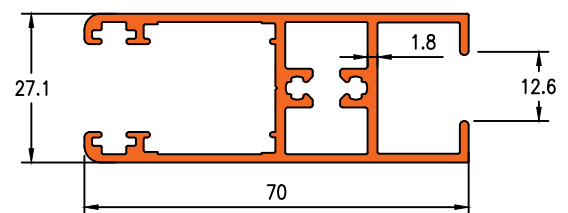



Die No. 16105

1.856KG/M

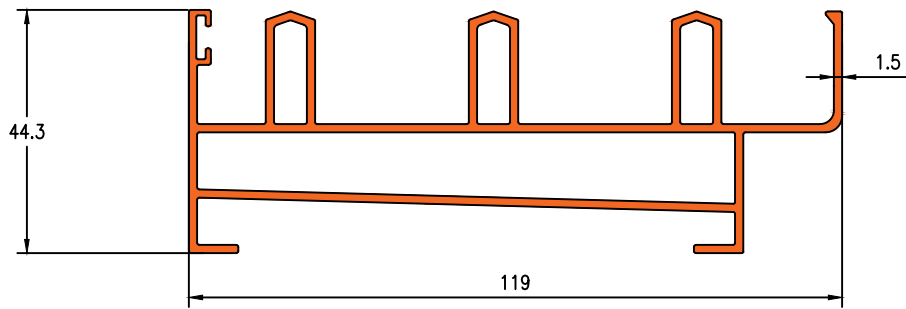

Die No. 16106

0.970KG/M

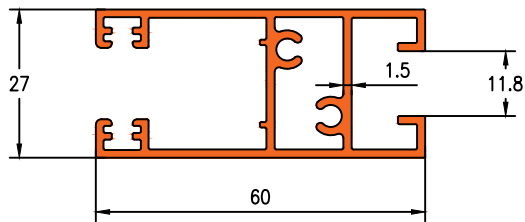

Die No. 16108

0.612KG/M

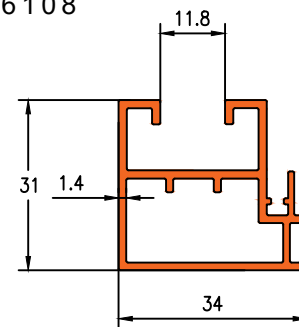

Die No. 16107

1.347KG/M

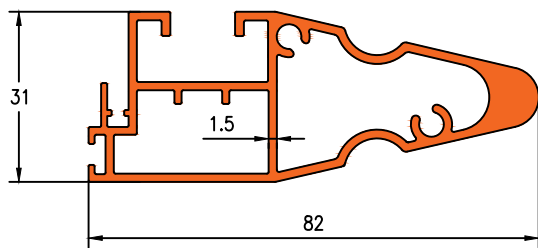

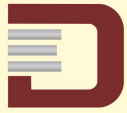

Die No. 16138

0.629KG/M

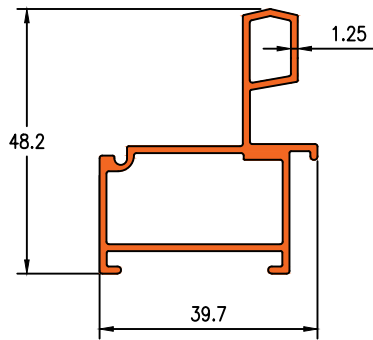

Die No. 16137

1.112KG/M

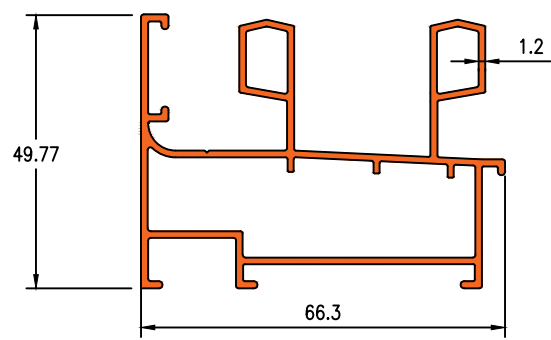

Die No. 16136

1.584 KG/M

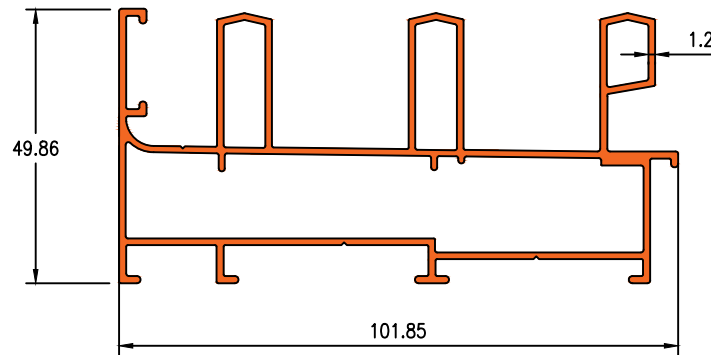

Die No. 16135

2.225KG/M

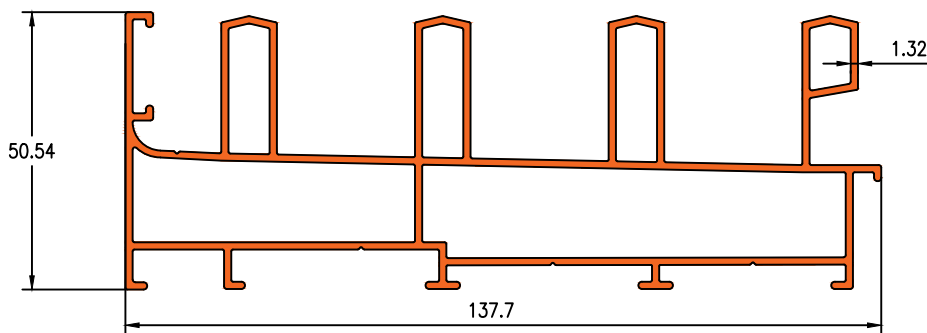

Die No. 19537

3.091KG/M

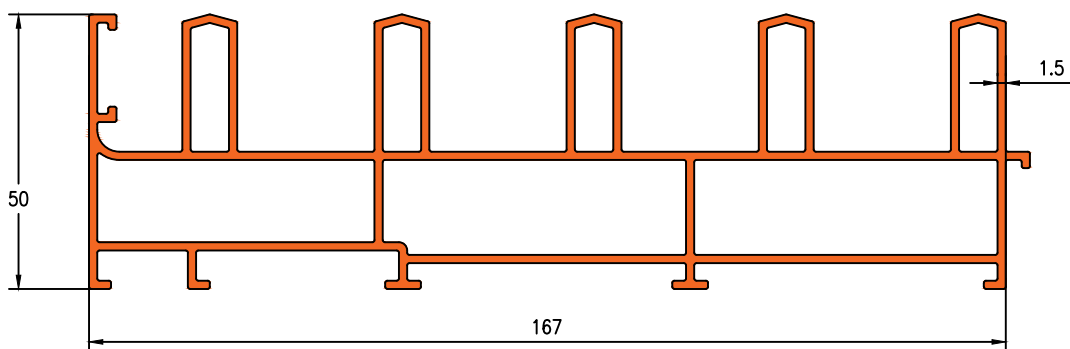

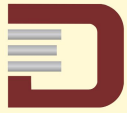

Die No. 16140

0.744KG/M

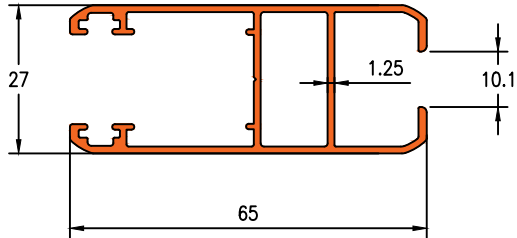

Die No. 16139

0.723KG/M

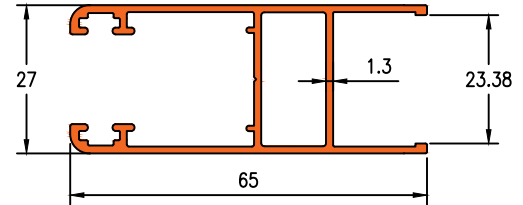

Die No. 19722

0.699KG/M

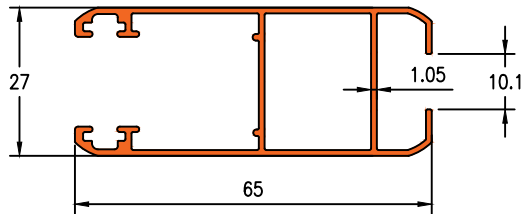

Die No. 21019

0.794KG/M

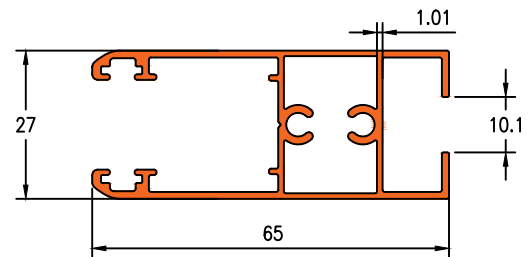

Die No. 20028

0.549KG/M

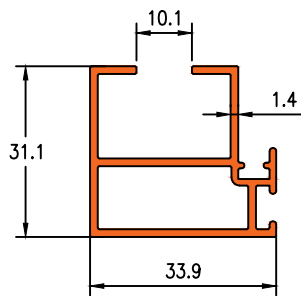

Die No. 20029

0.499KG/M

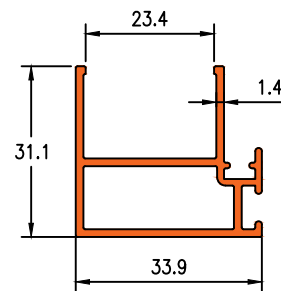

Die No. 20065

1.204KG/M

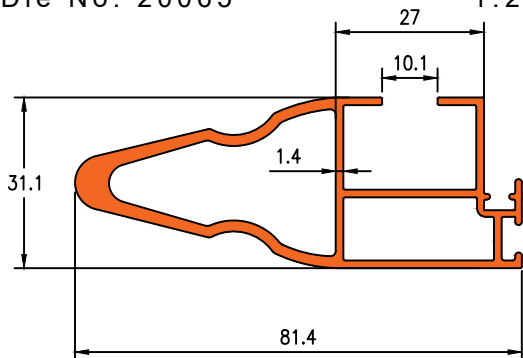

Die No. 21096

1.154 KG/M

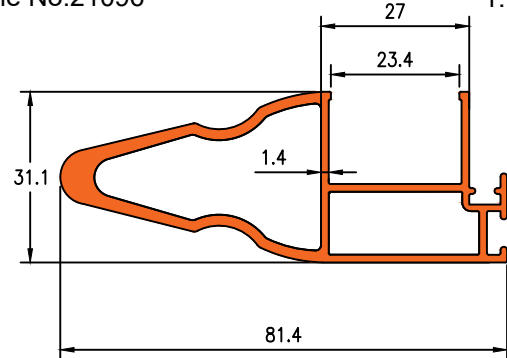



Die No. 16141

0.273KG/M

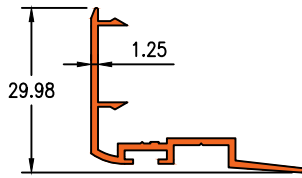

Die No. 19469

0.177KG/M

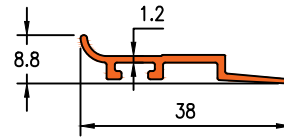

Die No. 19478

0.748KG/M

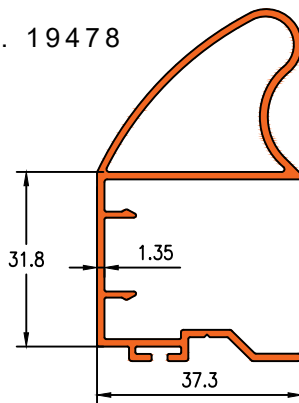

Die No. 20017

0.117KG/M

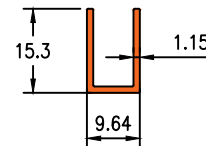

Die No. 21018

0.549KG/M

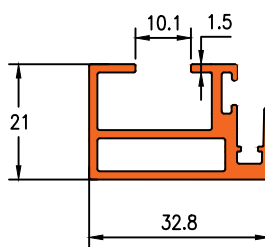

Die No. 23108

1.014KG/M

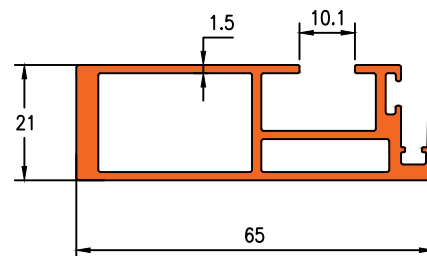



Die No. 5117

1.394KG/M

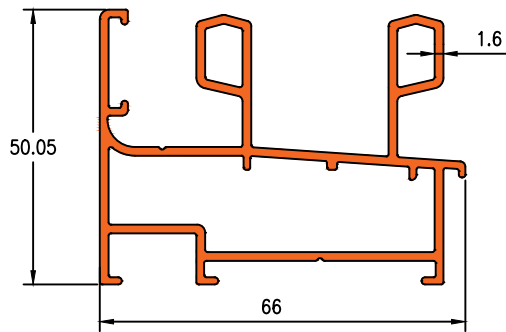

Die No. 16710

1.350KG/M

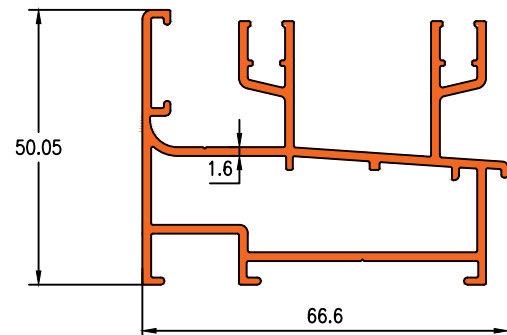

Die No. 5178

1.720KG/M

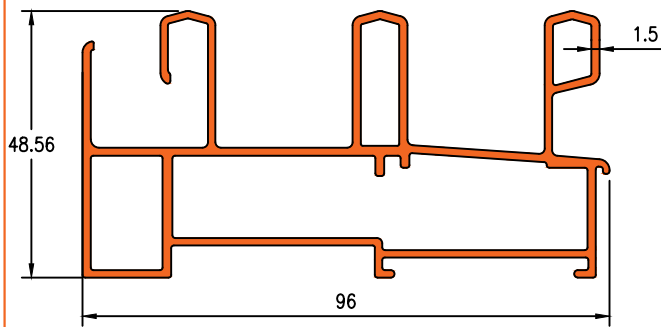

Die No. 5160

2.049KG/M

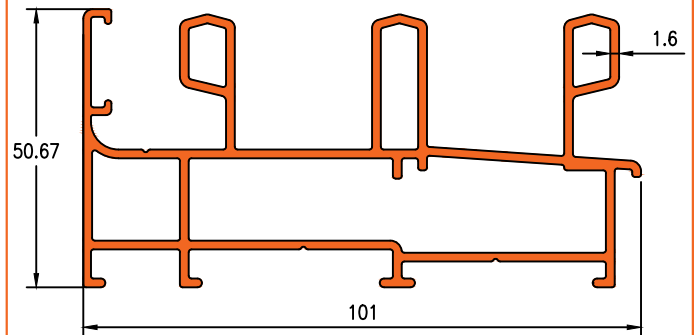

Die No. 5123

0.785KG/M

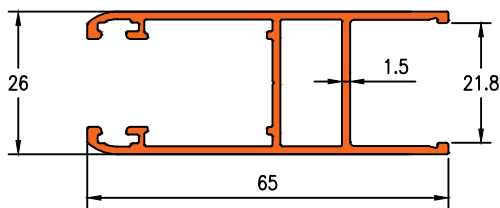

Die No. 5118

0.788KG/M

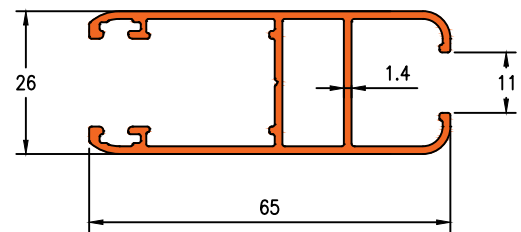

Die No. 5116

0.329KG/M

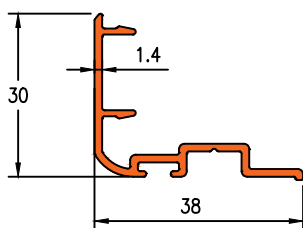

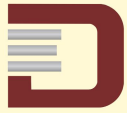

Die No. 21036

0.745KG/M

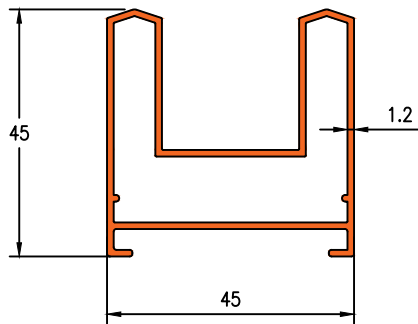

Die No. 21035

1.155KG/M

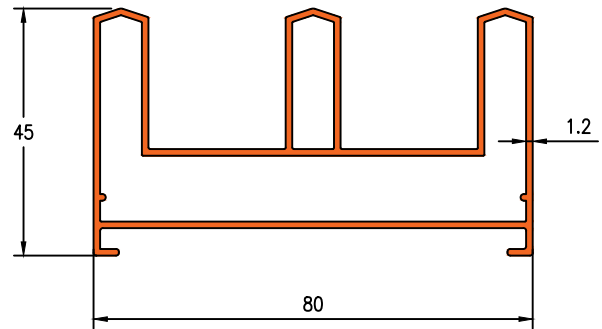

Die No. 21060

1.251KG/M

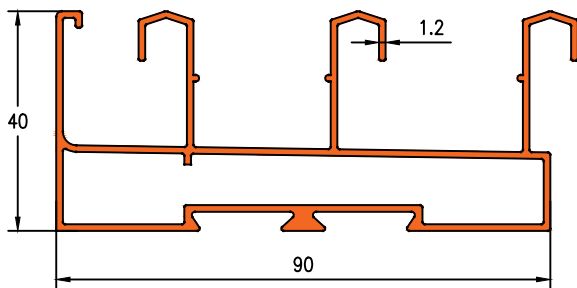

Die No. 21038

0.663KG/M

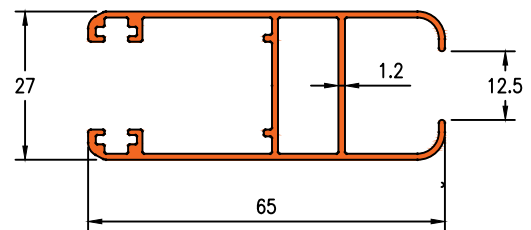

Die No. 16141

0.273KG/M

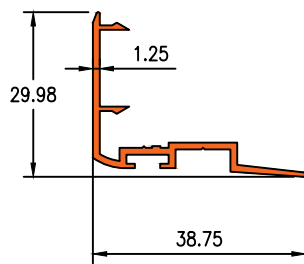

Die No. 21039

1.026KG/M

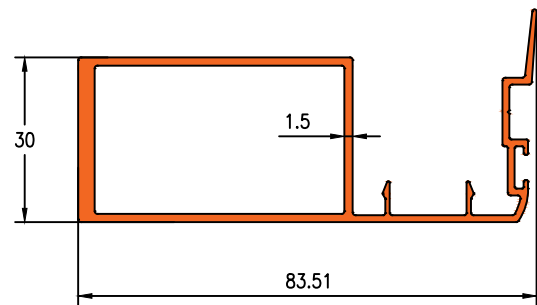



Die No. 19671

1.826KG/M

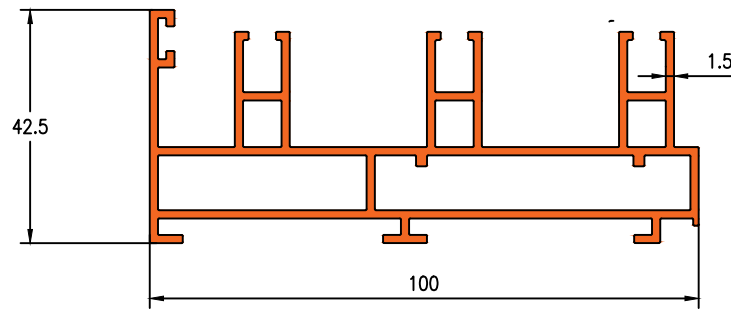

Die No. 16462

2.083KG/M

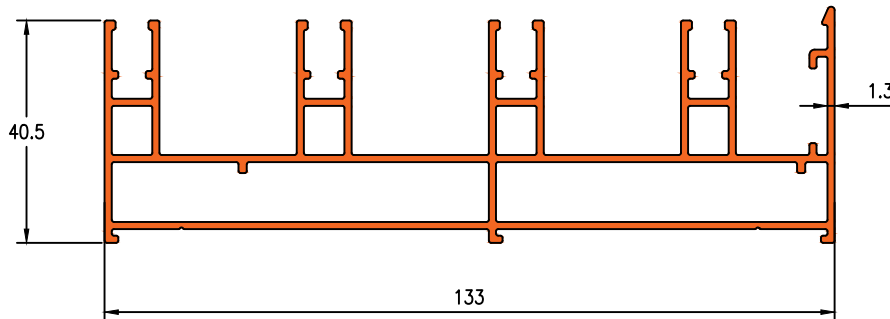

Die No. 19669

0.871KG/M

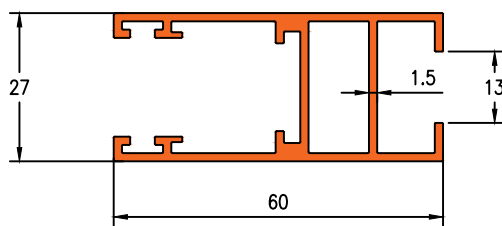

Die No. 19670

0.717KG/M

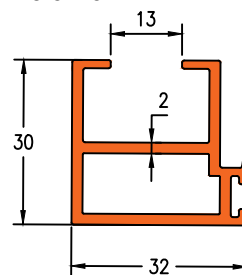

Die No. 19672
0.094KG/M

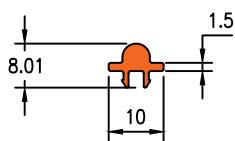

Die No. 19674
0.218KG/M

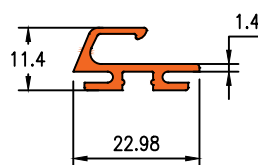

Die No. 19673

1.380KG/M

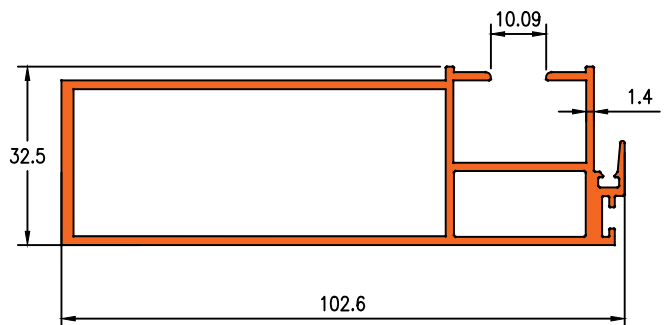

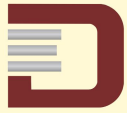

Enq No. 1556

1.109KG/M

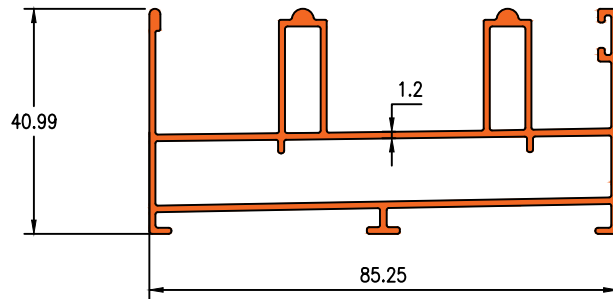

Enq No. 1550

1.470 KG/M

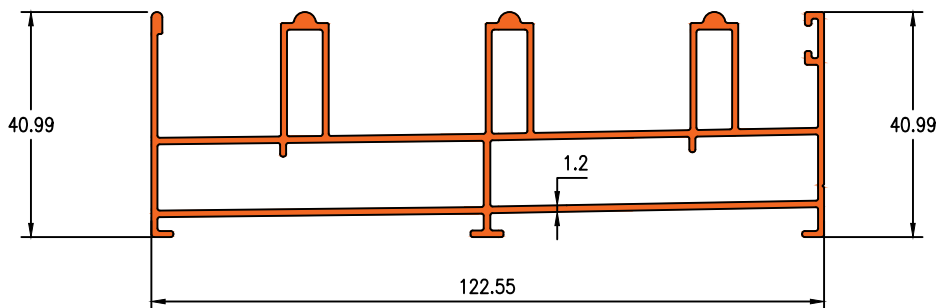

Enq No. 1551

0.774KG/M

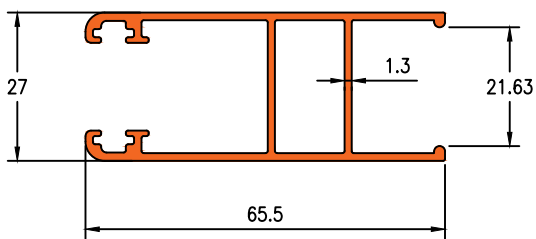

Enq No. 1553

0.490KG/M

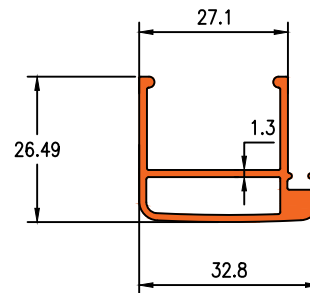

Enq No. 1554

0.809KG/M

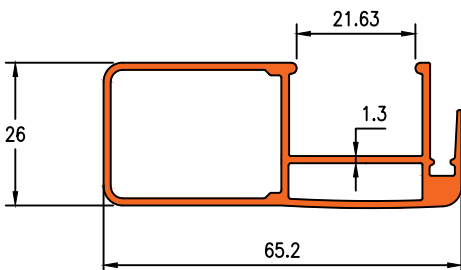

Enq No. 1552

0.721KG/M

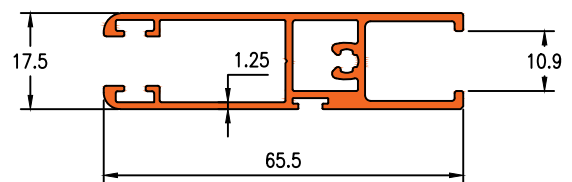



Enq No. 1555

0.193KG/M

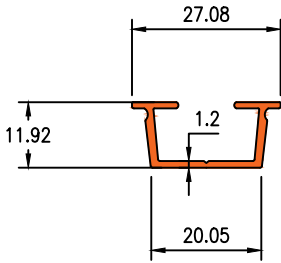



Enq No. 1562

1.314 KG/M

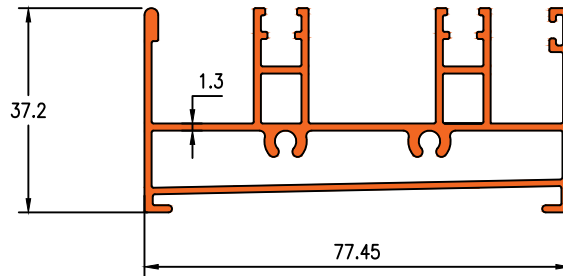

Enq No. 1563

1.725 KG/M

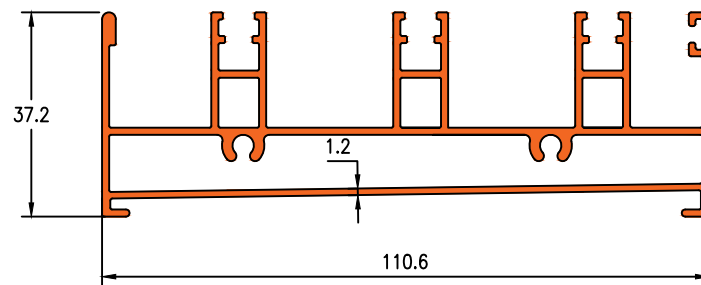

Enq No. 1558

0.815KG/M

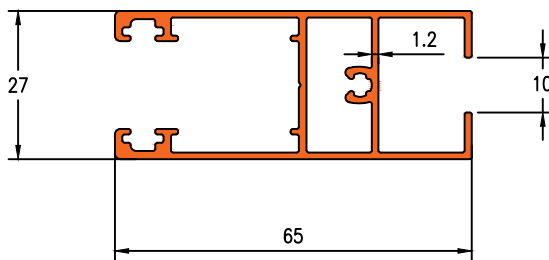

Enq No. 1559

0.590KG/M

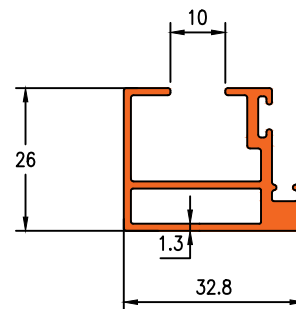

Enq No. 1560

0.992KG/M

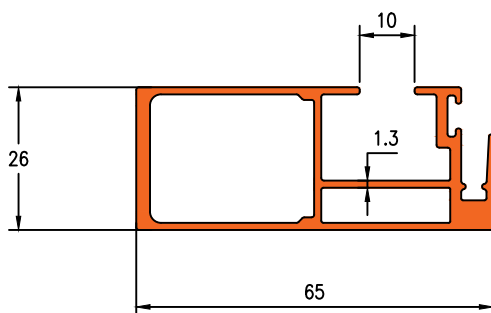

Enq No. 1561

0.639KG/M

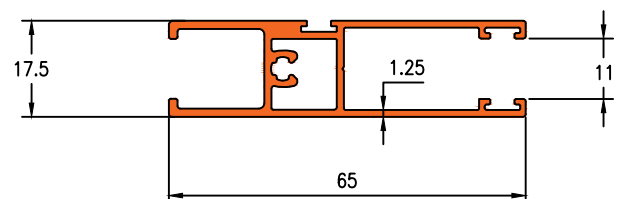

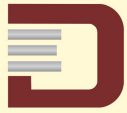

Enq No. 1959

1.242 KG/M

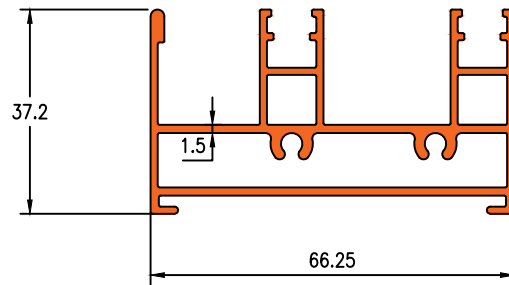

Enq No. 1960

1.717 KG/M

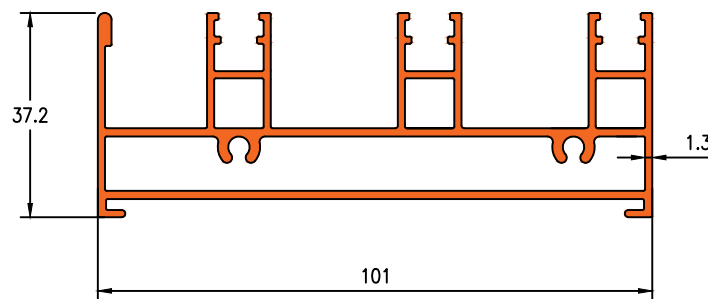

Enq No. 1961

0.877KG/M

Enq No. 1962

0.633KG/M

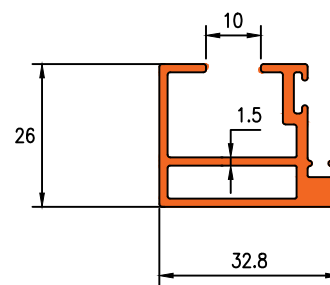
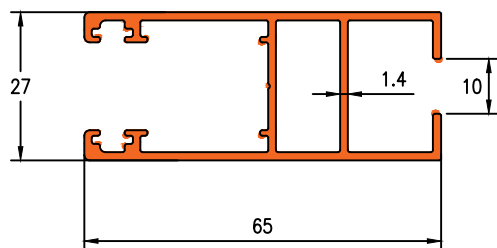

Enq No. 1963

1.161KG/M

