

Die No.	T	W / 12FT
1611	0.80	1.400-1.600
1611	0.95	1.600-1.800
1611	1.05	1.800-2.000
1611	1.20	2.000-2.200
1611	1.30	2.200-2.400
1611	1.40	2.400-2.600

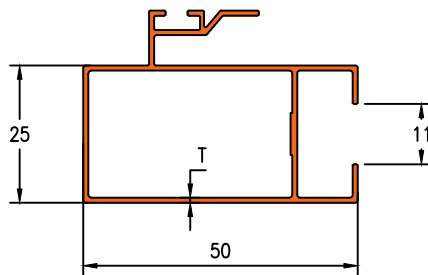

Die No.	T	W / 12FT
1615	0.95	1.800-2.000
1615	1.05	2.000-2.200
1615	1.15	2.200-2.400
1615	1.25	2.400-2.600
1615	1.45	2.800-3.000

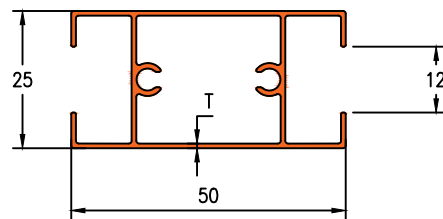

Die No.	T	W / 12FT
1612	0.90	1.600-1.800
1612	1.00	1.800-2.000

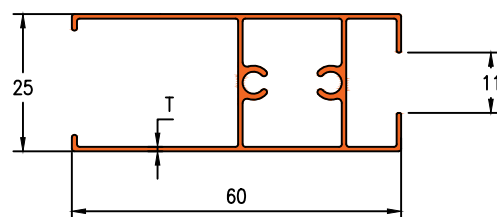

Die No.	T	W / 12FT
1621	0.95	1.800-2.00
1621	1.05	2.000-2.200
1621	1.15	2.200-2.400
1621	1.20	2.400-2.600
1621	1.30	2.600-2.800
1621	1.40	2.800-3.000



Die No. 16026

2.510 KG/12FT

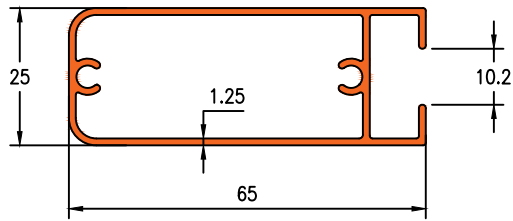

Die No. 1340

2.750 KG/12FT

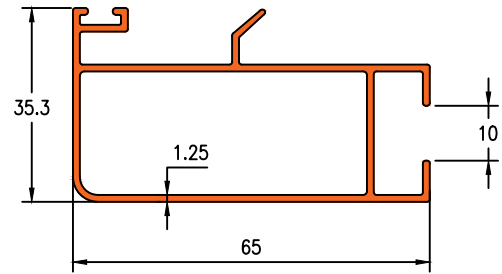

Die No. 1340M

2.450 KG/12FT

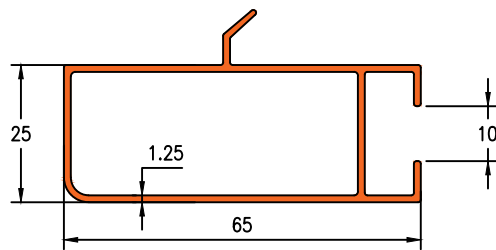

Die No. 1339

2.870KG/12FT

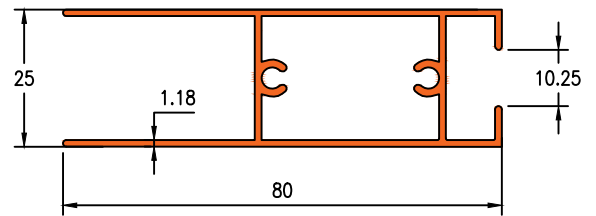

Die No. 1341

2.570 KG/12FT

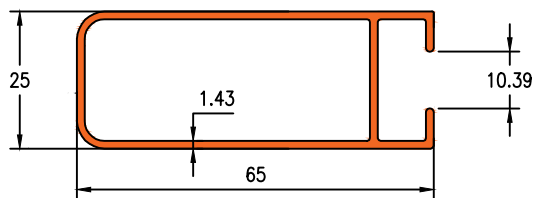

Die No. 16165

2.780 KG/12FT

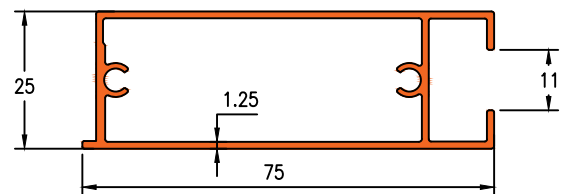

Die No. 16166

2.940 KG/12FT

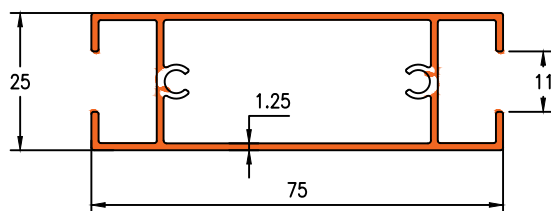

Die No. 10059

2.490 KG/12FT

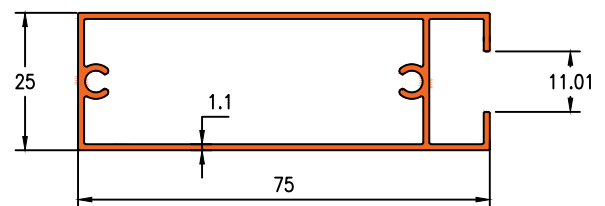

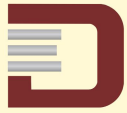

Die No. 21136

3.000 KG/12FT

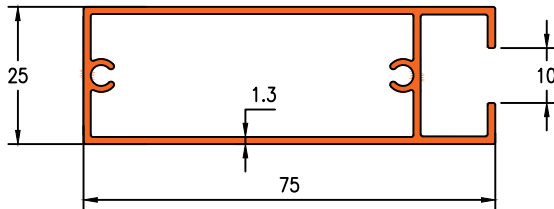

Die No. 21137

3.000 KG/12FT

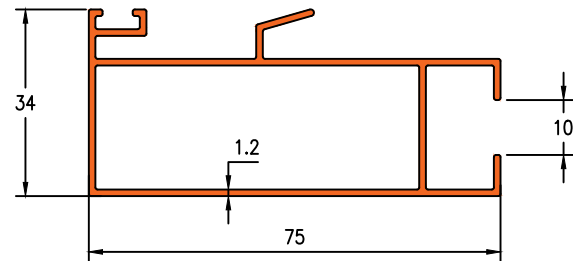

Die No. 21138

3.100 KG/12FT

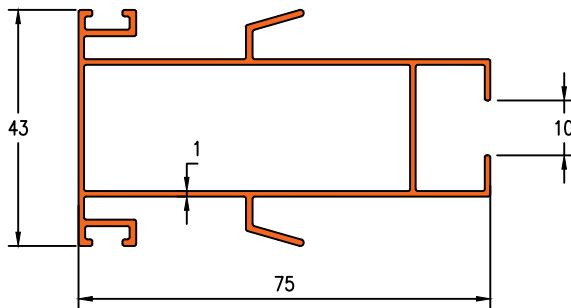

Die No. 21139

3.000 KG/12FT

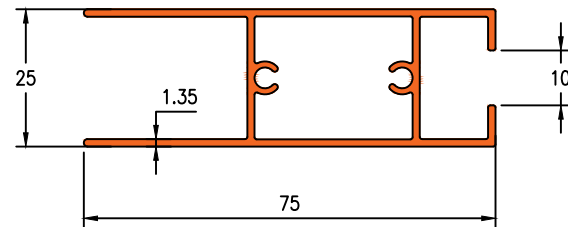

Die No. 21140

1.500 KG/12FT

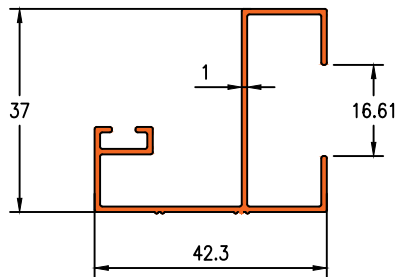

Die No. 21141

0.800 KG/12FT

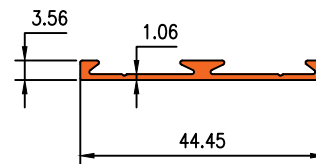

Die No. 21143

1.500 KG/12FT

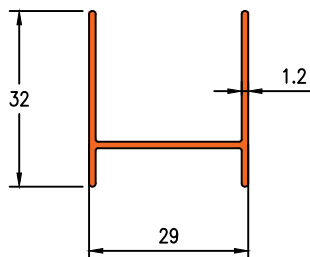



Die No. 16229

1.860 KG/12FT
1.400 KG/12FT

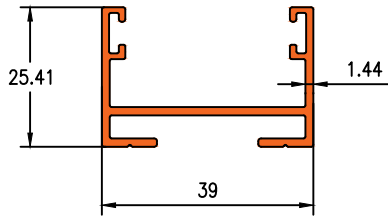

Die No. 16230

1.860 KG/12FT
1.500 KG/12FT

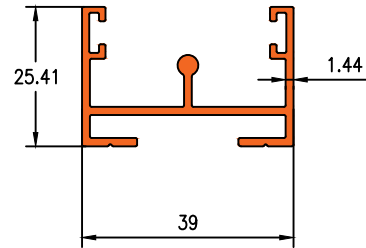

Die No. 1151

2.090 KG/12FT

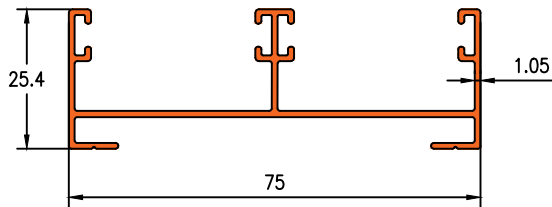

Die No. 1156

2.300 KG/12FT

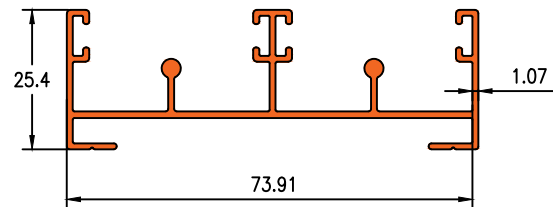

Die No. 1161

3.100 KG/12FT
3.340 KG/12FT
3.700 KG/12FT

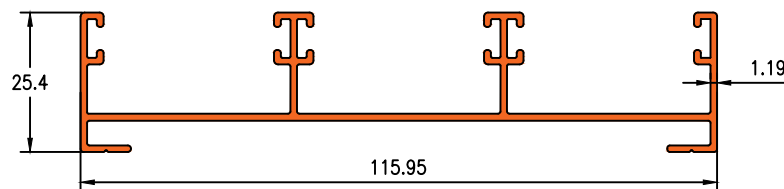

Die No. 1166

3.560 KG/12FT
4.000 KG/12FT

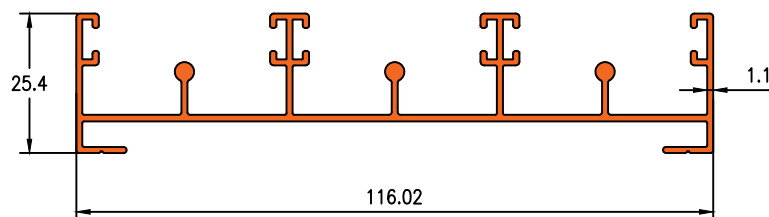

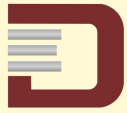

Die No. 16080

4.200 KG/12FT
4.800 KG/12FT

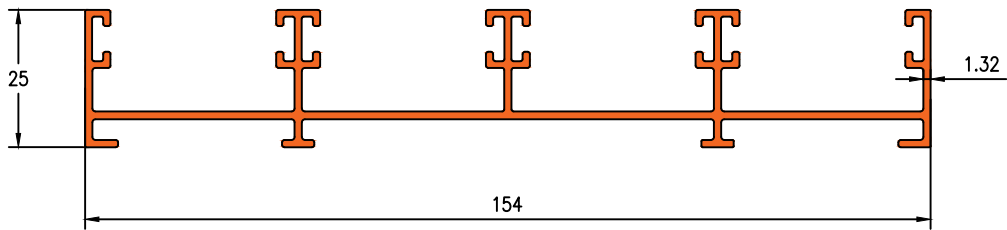

Die No. 16081

5.215 KG/12FT
6.100 KG/12FT

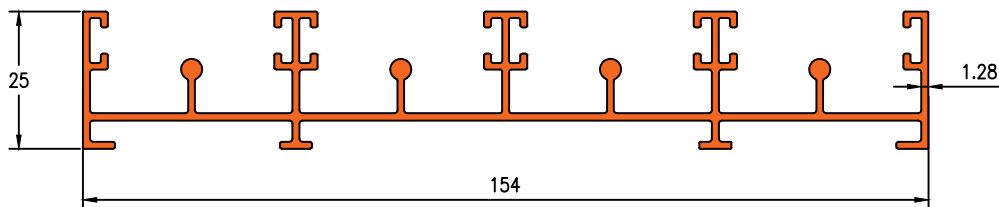

Die No. 16146

6.200 KG/12FT

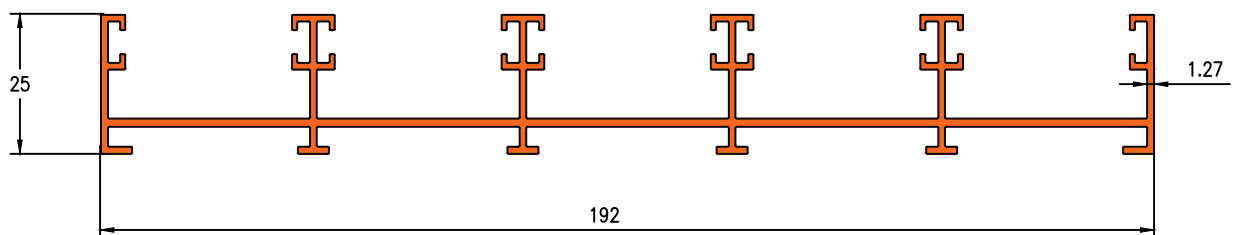

Die No. 16147

7.300 KG/12FT

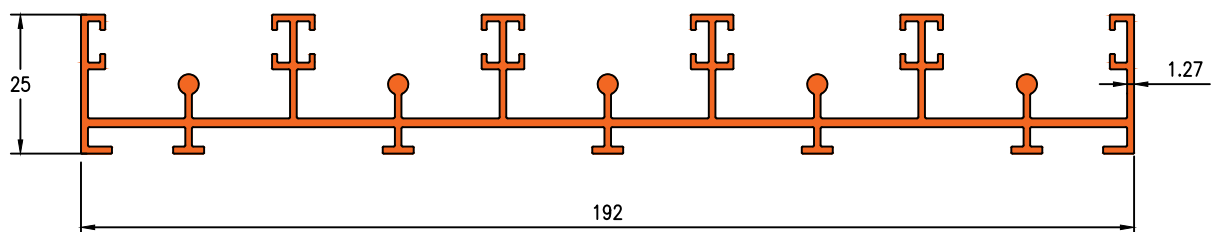



Die No. 19459

3.870 KG/12FT

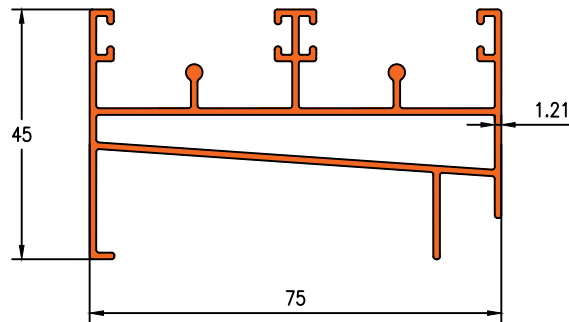

Die No. 19426

5.930 KG/12FT

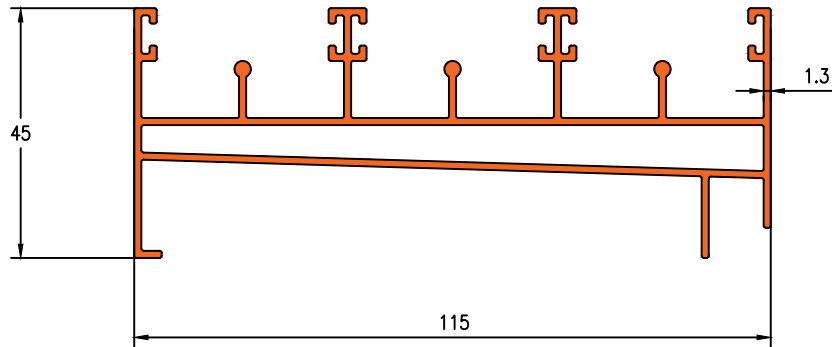

Die No. 19820

5.280 KG/12FT

