

Die No. 16119

0.962KG/M

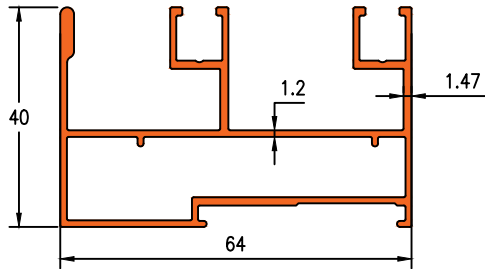

Die No. 16118

1.357KG/M

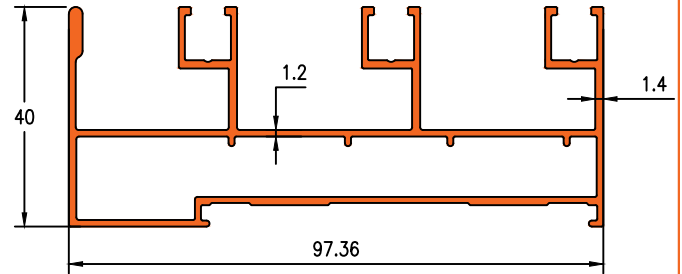

Die No. 16120

0.583KG/M

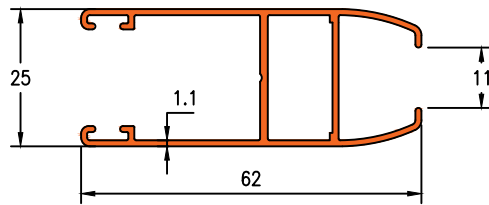

Die No. 16121

0.399 KG/M

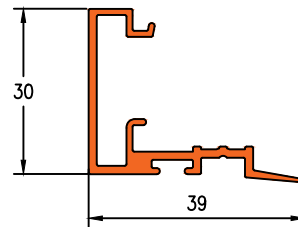

CLIP : 16121



Die No. 19454

0.722KG/M

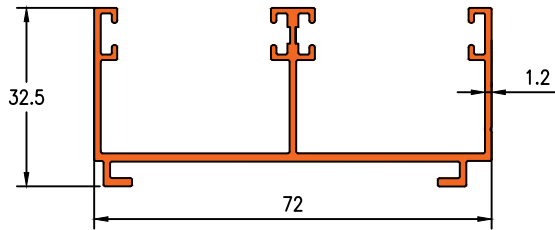

Die No. 19391

0.981KG/M

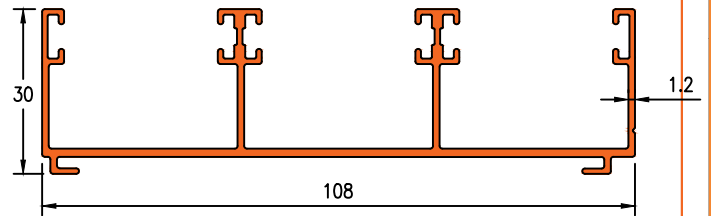

Die No. 19453

1.343KG/M

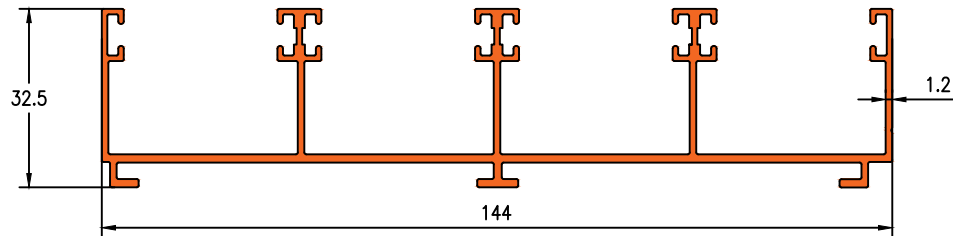

Die No. 19835

0.512KG/M

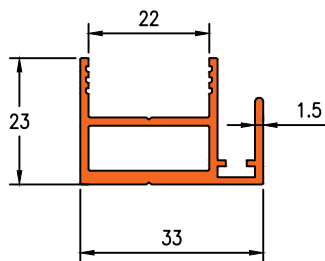

Die No. 19389

0.502KG/M

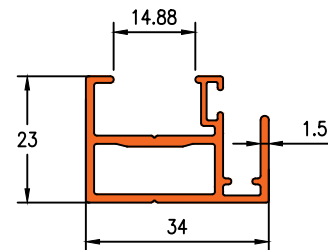

Die No. 19388

0.729KG/M

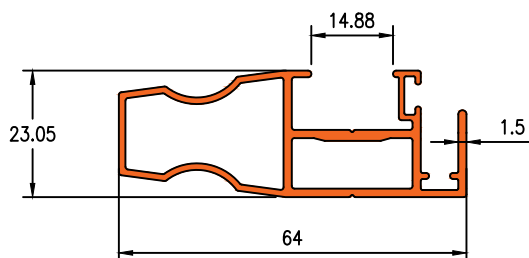

Die No. 19387

0.575KG/M

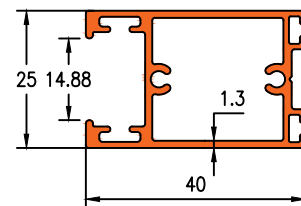

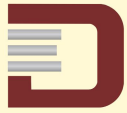

Die No. 19836

0.578KG/M

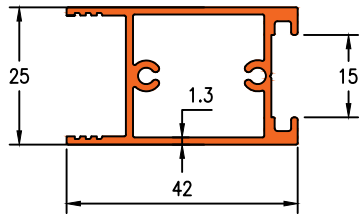

Die No. 19386

0.567KG/M

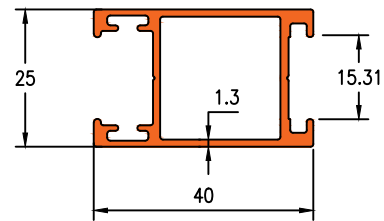

Die No. 19390

0.286KG/M

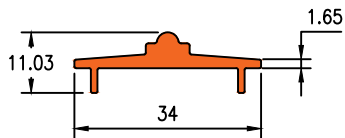



Die No.19920

0.624KG/M

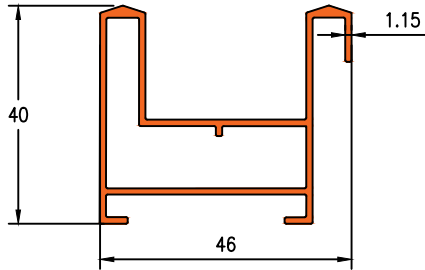

Die No.19917

0.965KG/M

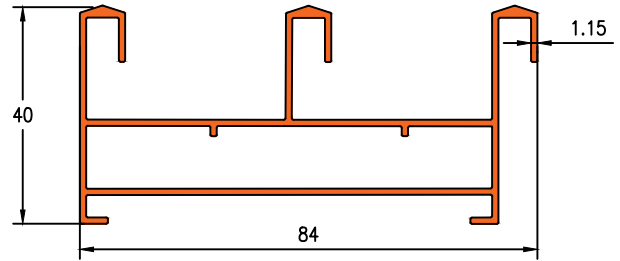

Die No. 16423

0.566KG/M

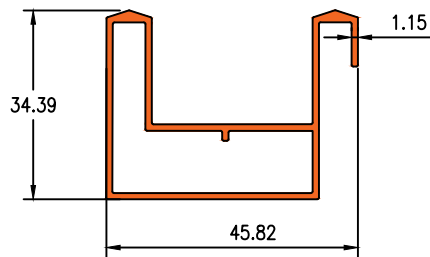

Die No.19656

0.908KG/M

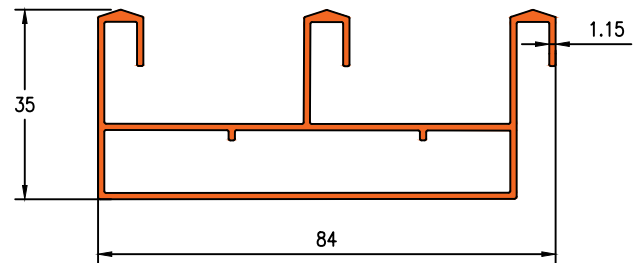

Die No.19677

0.814KG/M

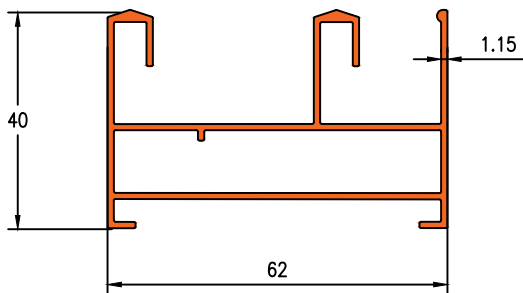

Die No.19678

1.176KG/M

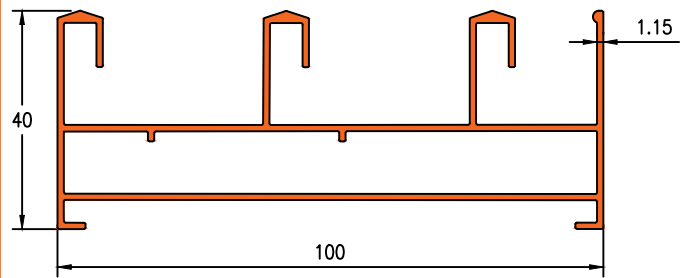

Die No. 16422

0.997KG/M

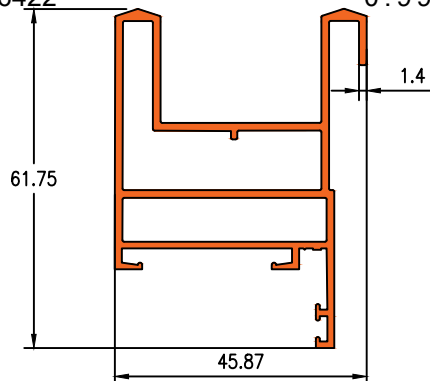

Die No.19650

1.324KG/M

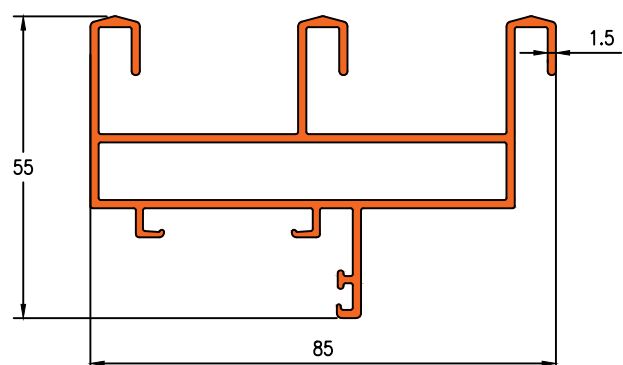

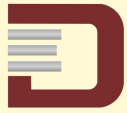

Die No.19951

1.064KG/M

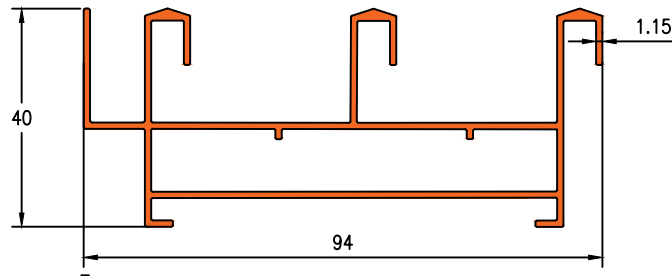

Die No.21251

1.609KG/M

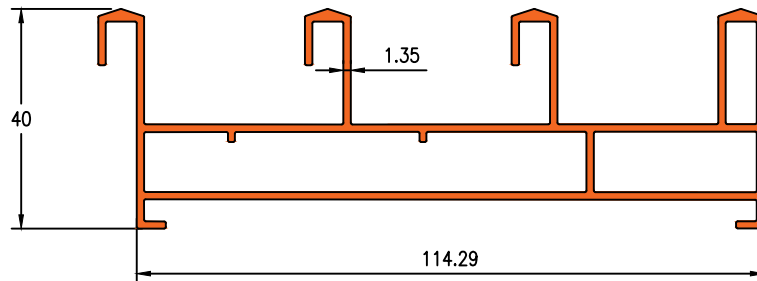

Die No. 16424

0.454KG/M

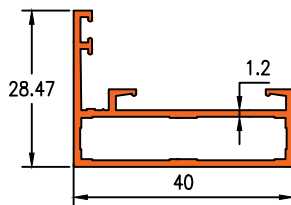

Die No.19916

0.647KG/M

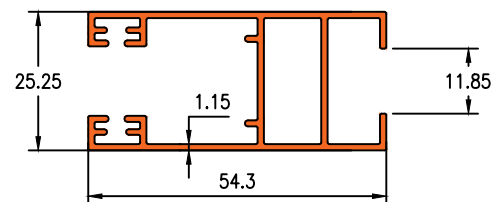

Die No.19913

0.402KG/M

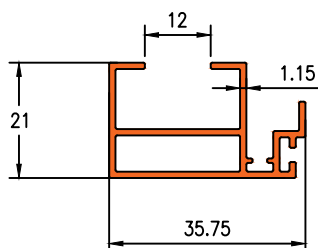

Die No.19475

0.661KG/M

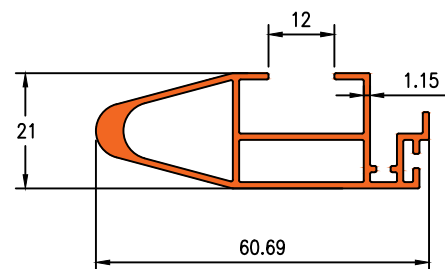



Die No.19950

0.601KG/M

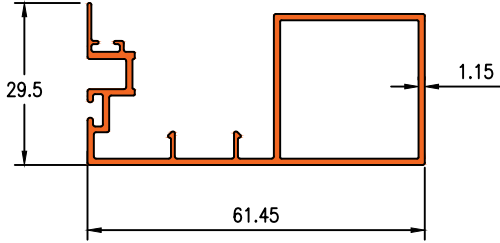

Die No.19662

0.251KG/M

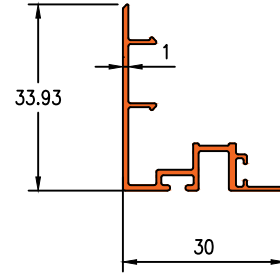

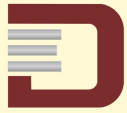

Die No. S7011

0.927KG/M

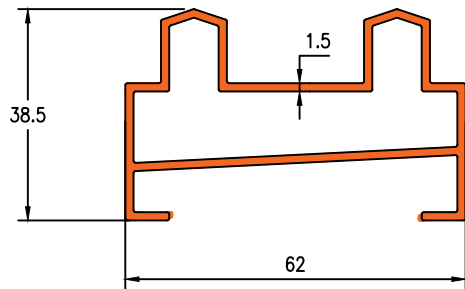

Die No. S7013

1.224KG/M

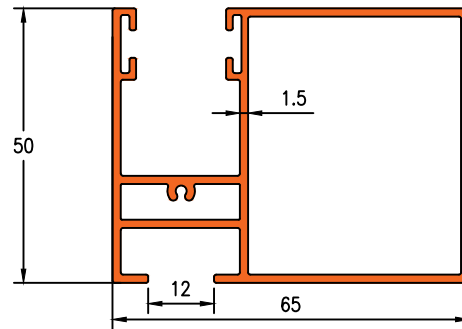

Die No. S7014

0.613KG/M

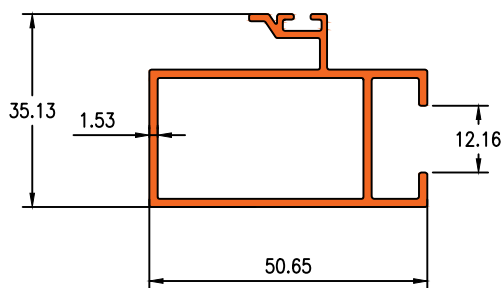

Die No. S7012

1.394 KG/M

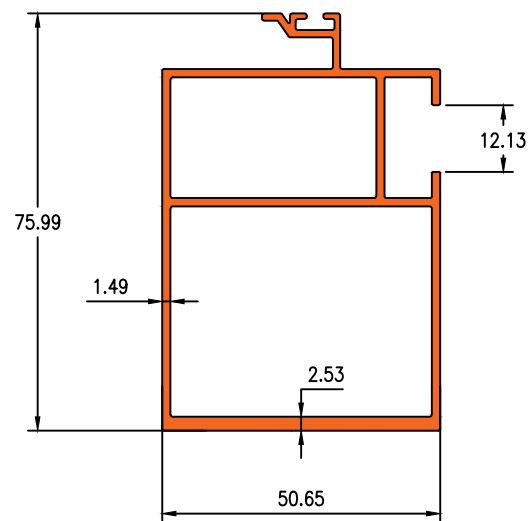

Die No. S7015

0.744KG/M

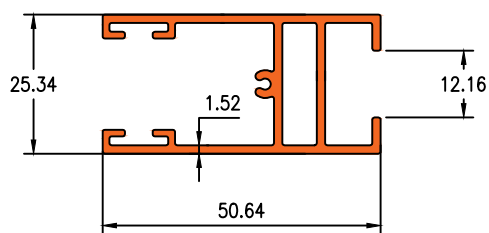



Die No. 19518

2.235KG/M

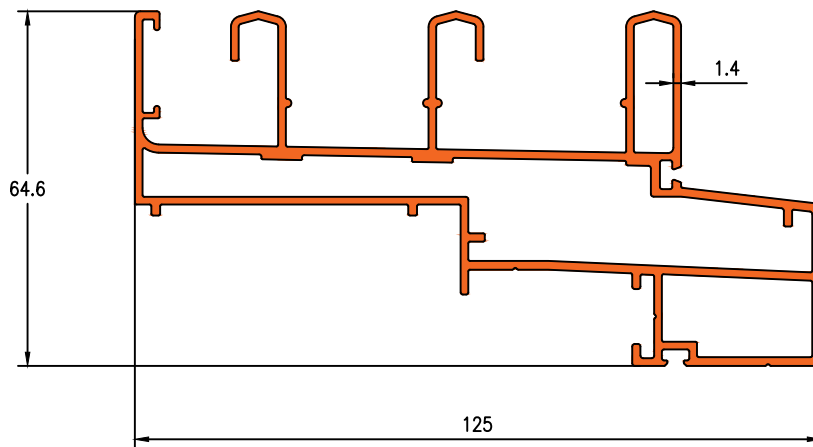

Die No. 19519

1.792KG/M

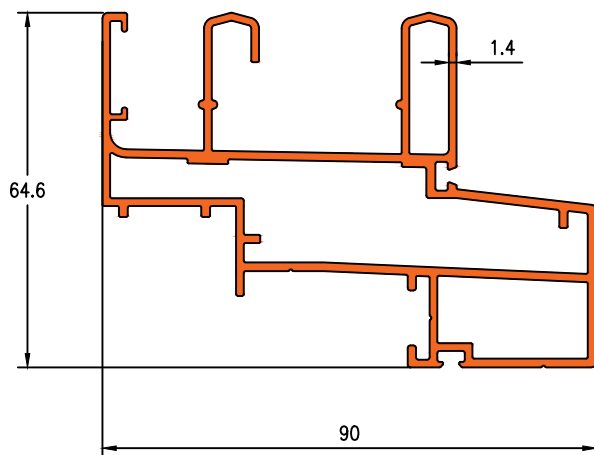

Die No. 19520

0.971KG/M

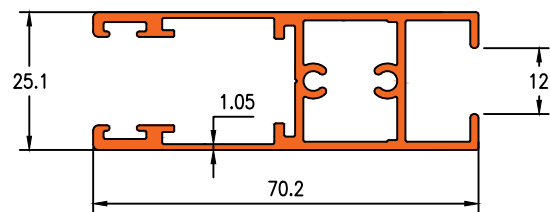

Die No. 19913

0.402KG/M

