

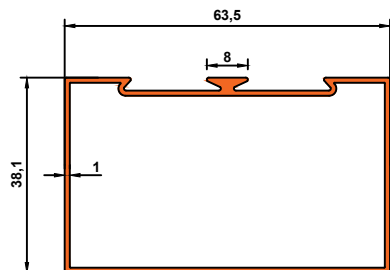

# Darshan Extrusions Pvt. Ltd.

Die No. 1701

0.519 Kg/m  
0.683 kg/m  
0.846 kg/m



Die No. 1721

0.519 Kg/m  
0.683 kg/m  
0.846 kg/m

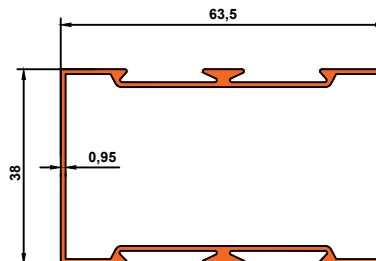

Die No. 1480

0.732 Kg/m

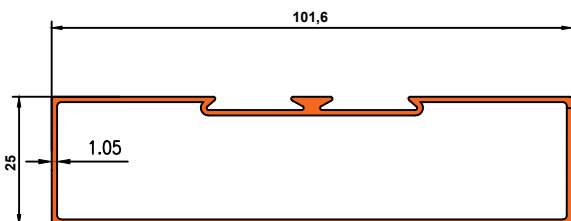

Die No. 1481

0.833 Kg/m

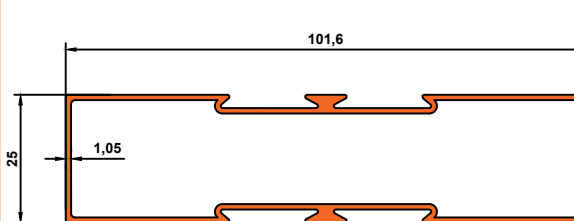

Die No. 1771

1.502 Kg/m  
2.377 kg/m

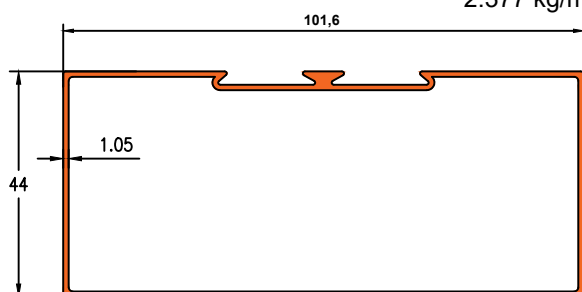

Die No. 1791

1.502 Kg/m  
2.431 kg/m

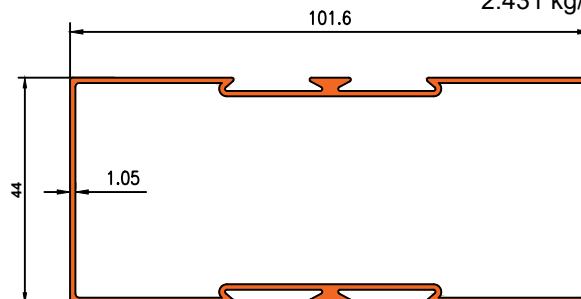

Die No. 3503

0.732 Kg/m

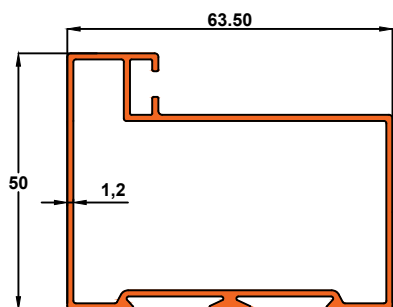

Die No. 1901

0.074 Kg/m

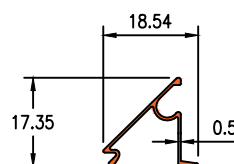

PARTITION



# Darshan Extrusions Pvt. Ltd.

Die No. 1741 0.573 Kg/m  
0.846 kg/m

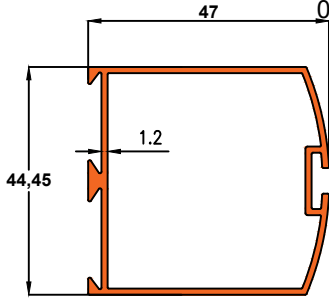

Die No. 2601 0.573 Kg/m

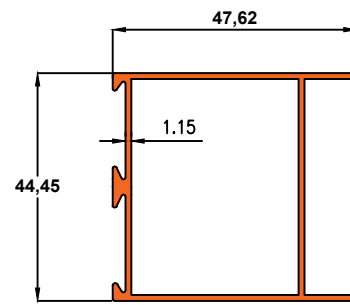

Die No. 1761 0.628 Kg/m

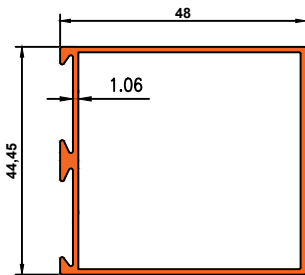

Die No. 2751 0.819 Kg/m

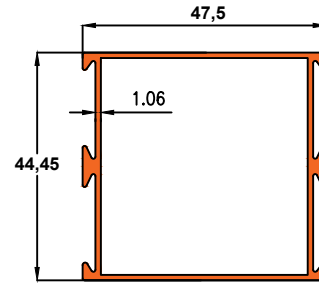

Die No. 1773 2.076 Kg/m

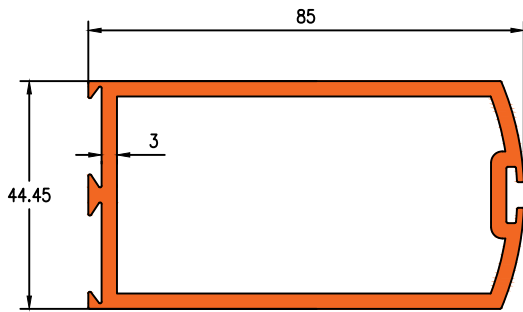

Die No. 1770 1.120 Kg/m

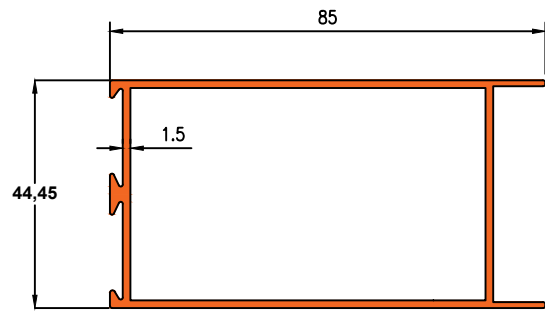

Die No. 1775 1.010 Kg/m

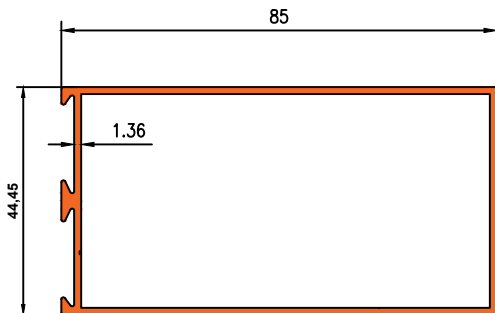

Die No. 1778 1.065 Kg/m

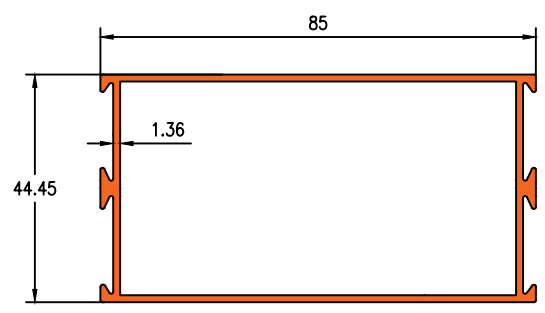

**PARTITION**



# Darshan Extrusions Pvt. Ltd.

Die No. 1181

1.393 Kg/m

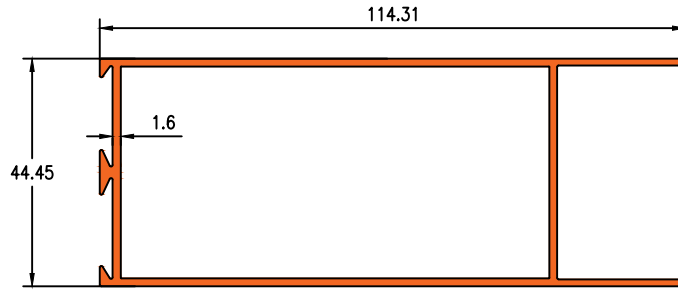



**PARTITION**



# Darshan Extrusions Pvt. Ltd.

Die No. 16082

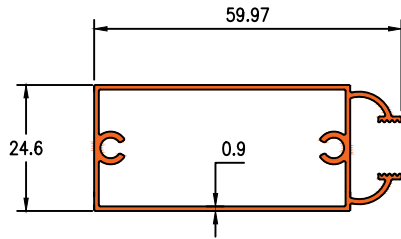
0.503Kg/m



Die No.19361

0.475Kg/m

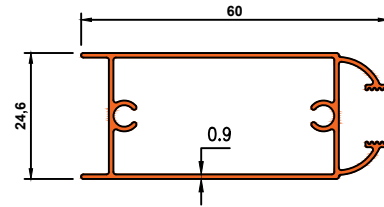

Die No. 16083

0.530Kg/m

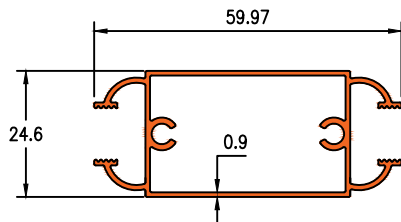

Die No. 16084

0.579Kg/m

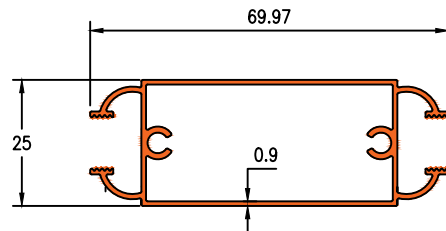

Die No. 16085

0.600Kg/m

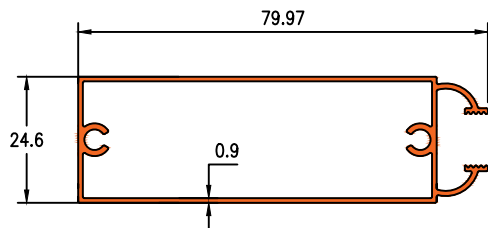

25 MM MOLDING HANDLES



# Darshan Extrusions Pvt. Ltd.

Die No. 16087

0.430 Kg/m

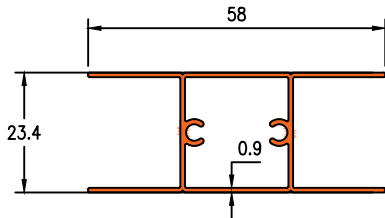

Die No. 16088

0.335 Kg/m

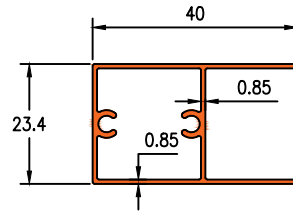

Die No. 21012

0.403 Kg/m

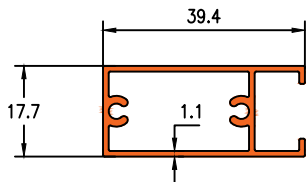

Die No. 5228

1.606 Kg/m

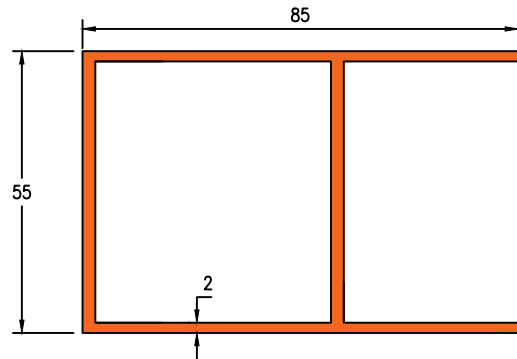

Die No. 21013

0.990 Kg/m

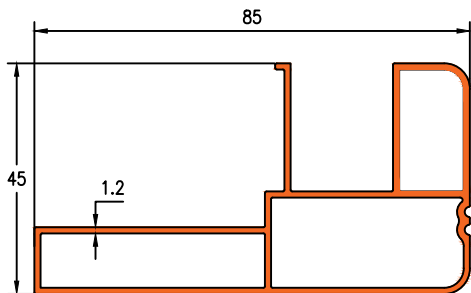

Die No. 7048

0.635 Kg/m

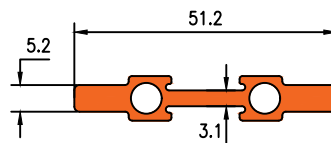

Die No. 7049

0.222 Kg/m

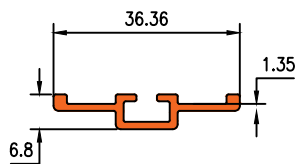

Die No. 7050

0.306 Kg/m

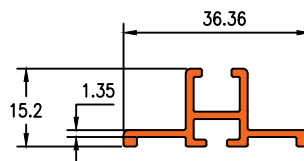

PARTITION



# Darshan Extrusions Pvt. Ltd.

Die No. 7017

0.367 Kg/m

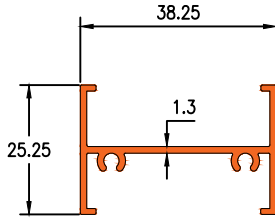

Die No. 7018

0.367 Kg/m

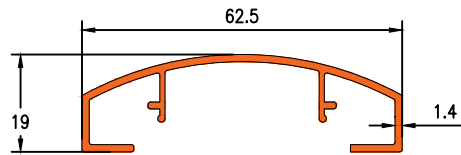

Die No. 7019

0.595 Kg/m

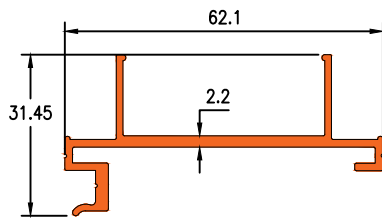

Die No. 7020

0.506 Kg/m

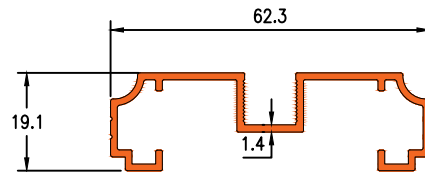

Die No. 7021

0.594 Kg/m

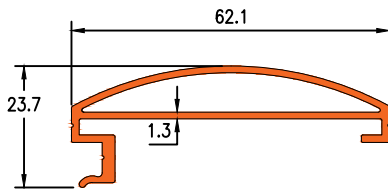

Die No. 7022

1.453 Kg/m

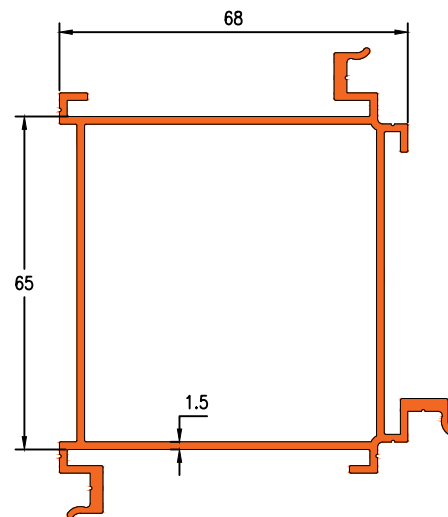

Die No. 7023

1.116 Kg/m

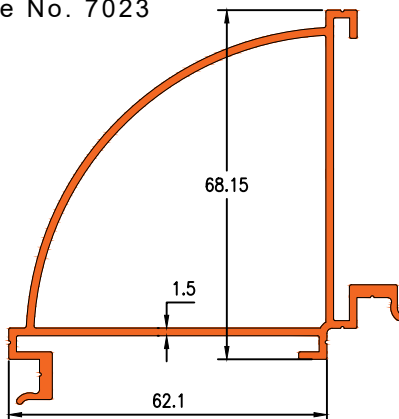

PARTITION



# Darshan Extrusions Pvt. Ltd.

Die No. 19613

1.595 Kg/m

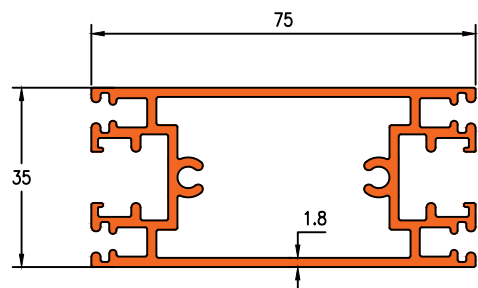

Die No. 19954

0.600 Kg/m

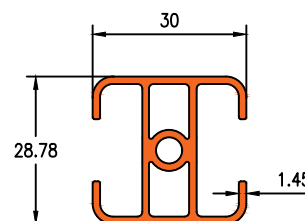

Die No. 19628

1.111 Kg/m

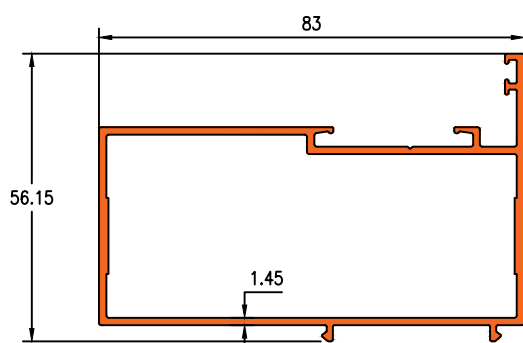

Die No. 19629

0.985 Kg/m

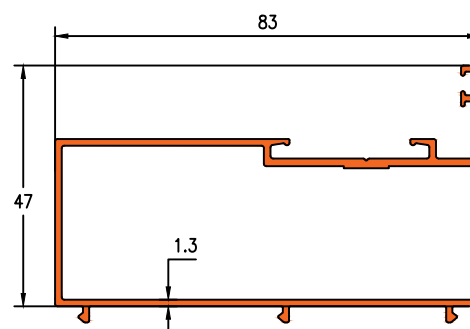

CLIP: 4006 & 4007

CLIP: 4006 & 4007

Die No. 19631

1.366 Kg/m

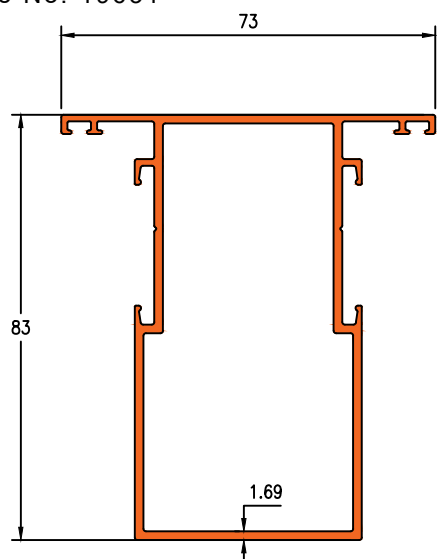

Die No. 19630

1.020 Kg/m

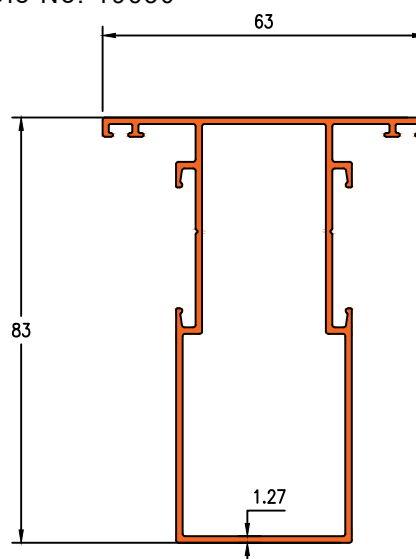

CLIP: 4006 & 4007

CLIP: 4006 & 4007

**PARTITION**



# Darshan Extrusions Pvt. Ltd.

Die No. 1268

0.412 Kg/m

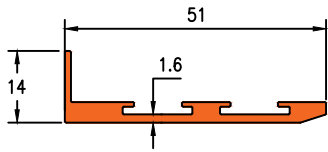

Die No. 19739

0.347 Kg/m

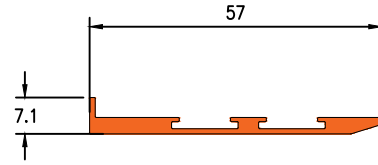

Die No. 19740

0.292 Kg/m

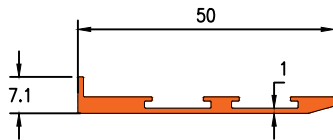

Die No. 23019

0.534 Kg/m

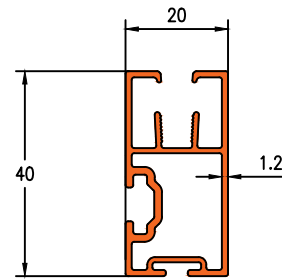

Die No. 16086

0.710 Kg/m

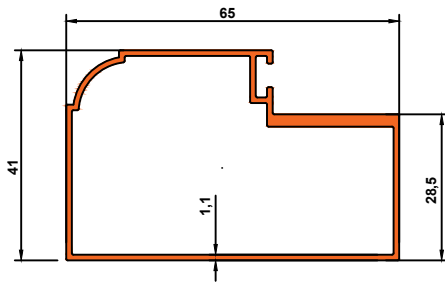

Die No. 16185

0.623 Kg/m

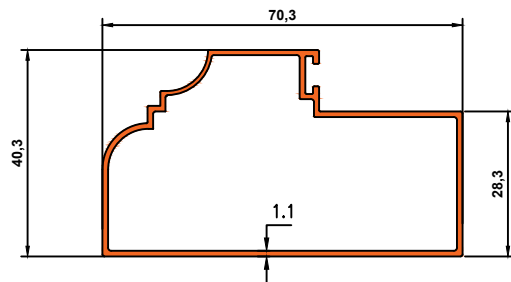

Die No. 10139

0.691 Kg/m

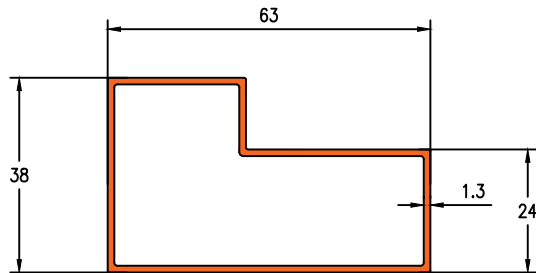

Die No. 10140

0.769 Kg/m

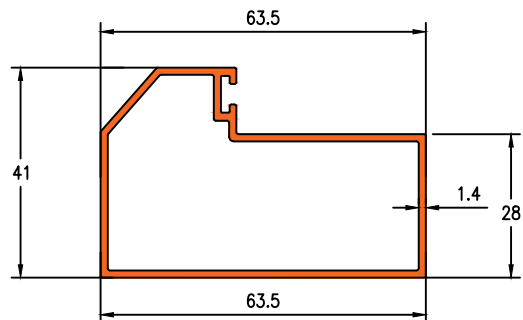

**PARTITION**





Die No. 19815

2.208 Kg/m

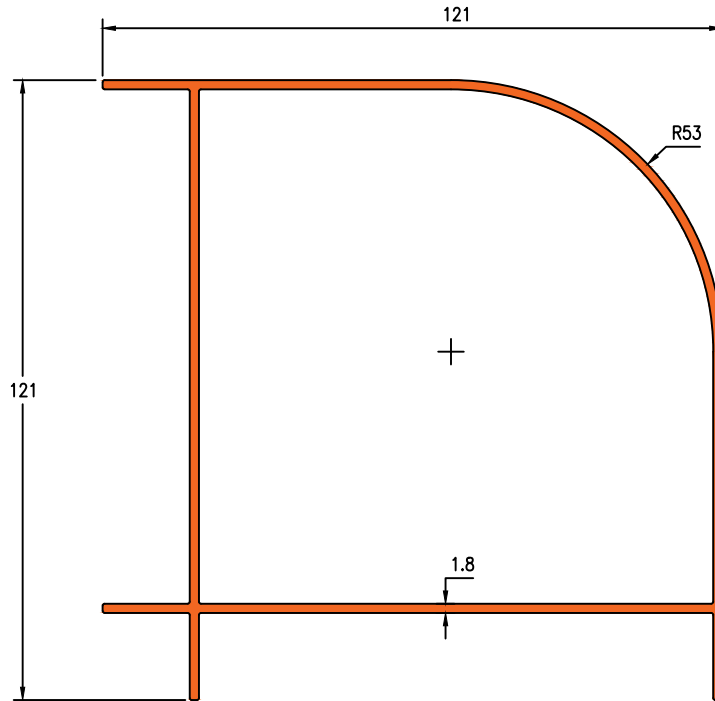

Die No. 19814

1.320 Kg/m

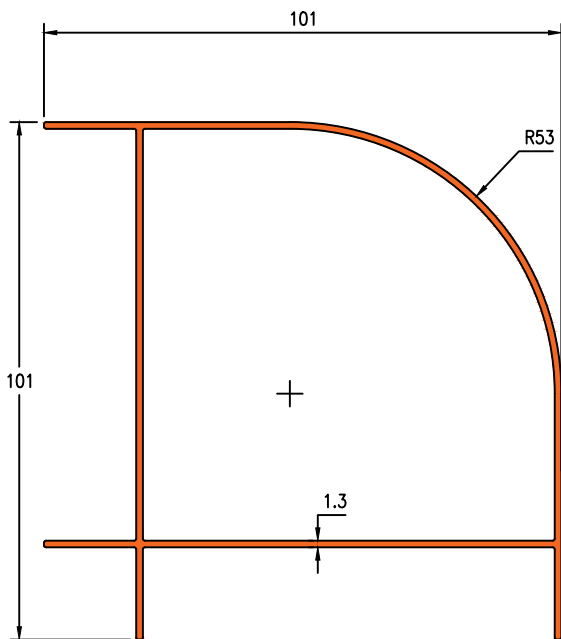

Die No. 19813

0.899 Kg/m

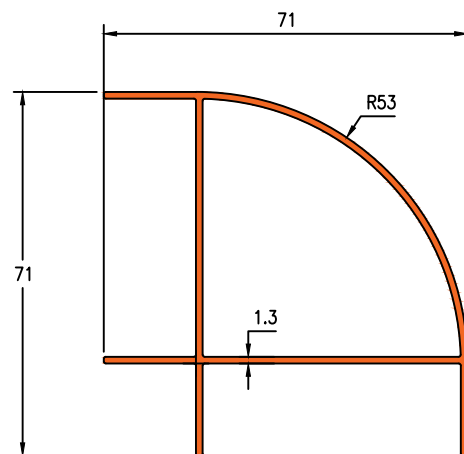



Die No. 16252

4.461 Kg/m

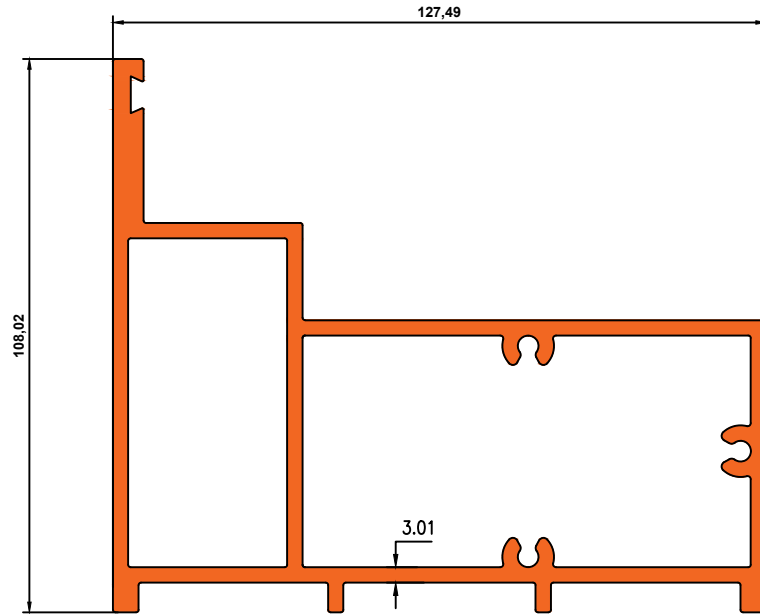

Die No. 16068

1.486 Kg/m

